

CONTENTS

Product Specification.....	1
Refrigeration Diagram.....	3
Wiring Diagram.....	6
Troubleshooting Guide.....	8

Chapter 1 Product Specification

1.1 Photo of Product (for reference only)

Indoor unit for L



Outdoor unit for L

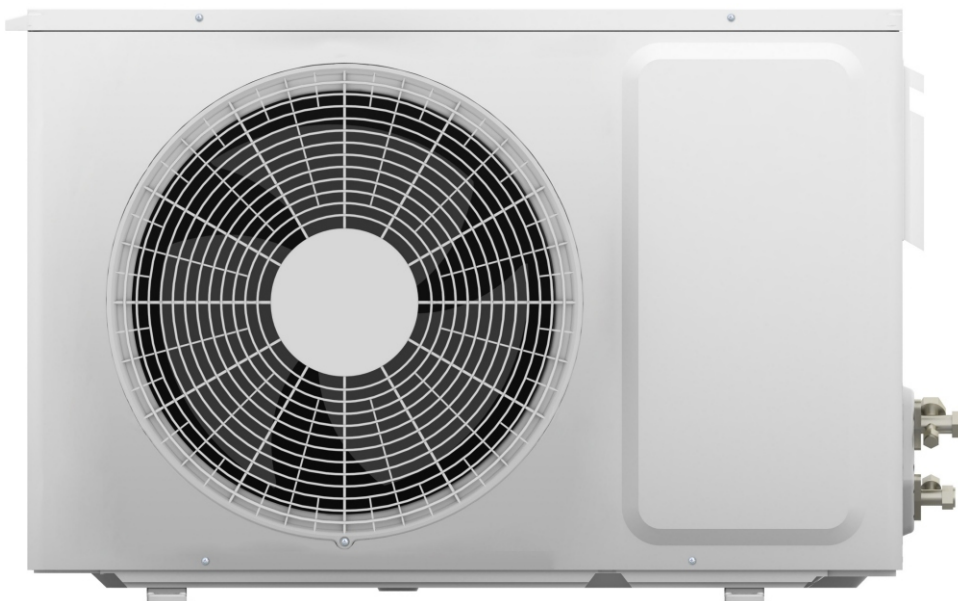

1.2 Outline Dimensions

Indoor Unit

MODEL		9000BTU	12000BTU	18000BTU	24000BTU
W	mm	700	700	850	970
D	mm	285	285	300	315
H	mm	188	188	197	235

Outdoor Unit

MODEL		9000BTU	12000BTU	18000BTU	24000BTU
W	mm	720	720	802	802
D	mm	255	255	298	298
H	mm	515	515	535	535

Chapter 2 Refrigeration Diagrams

2.1 Cooling Only

Cooling Mode

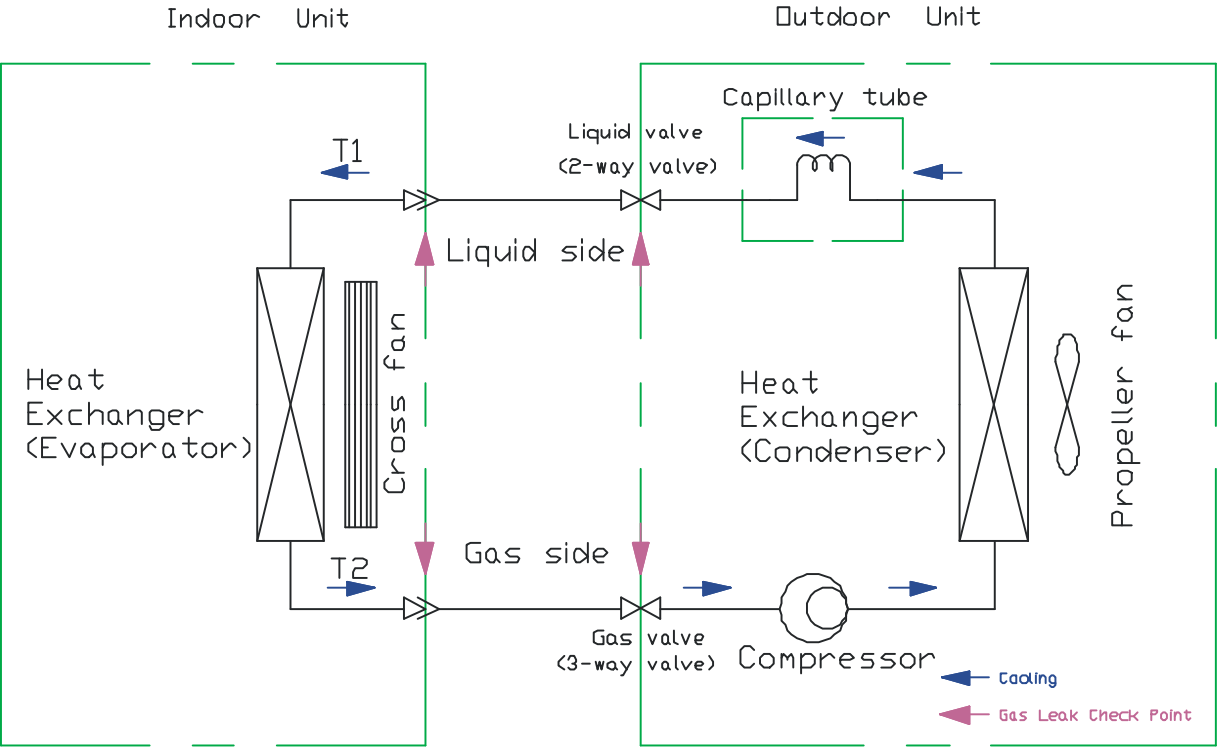

Cooling Cycle

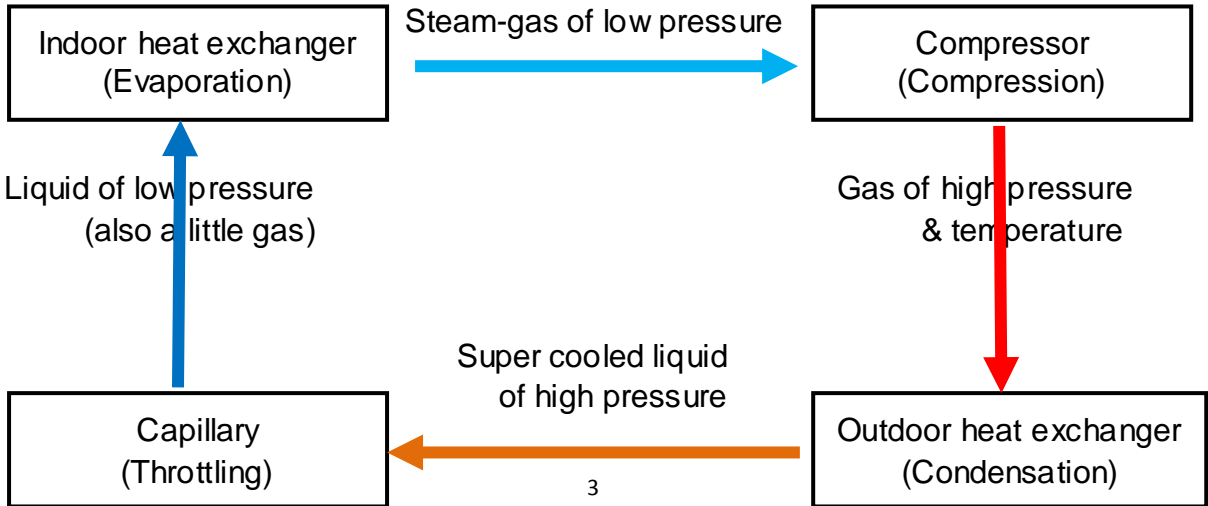

2.2 Cooling & Heating

Cooling Mode

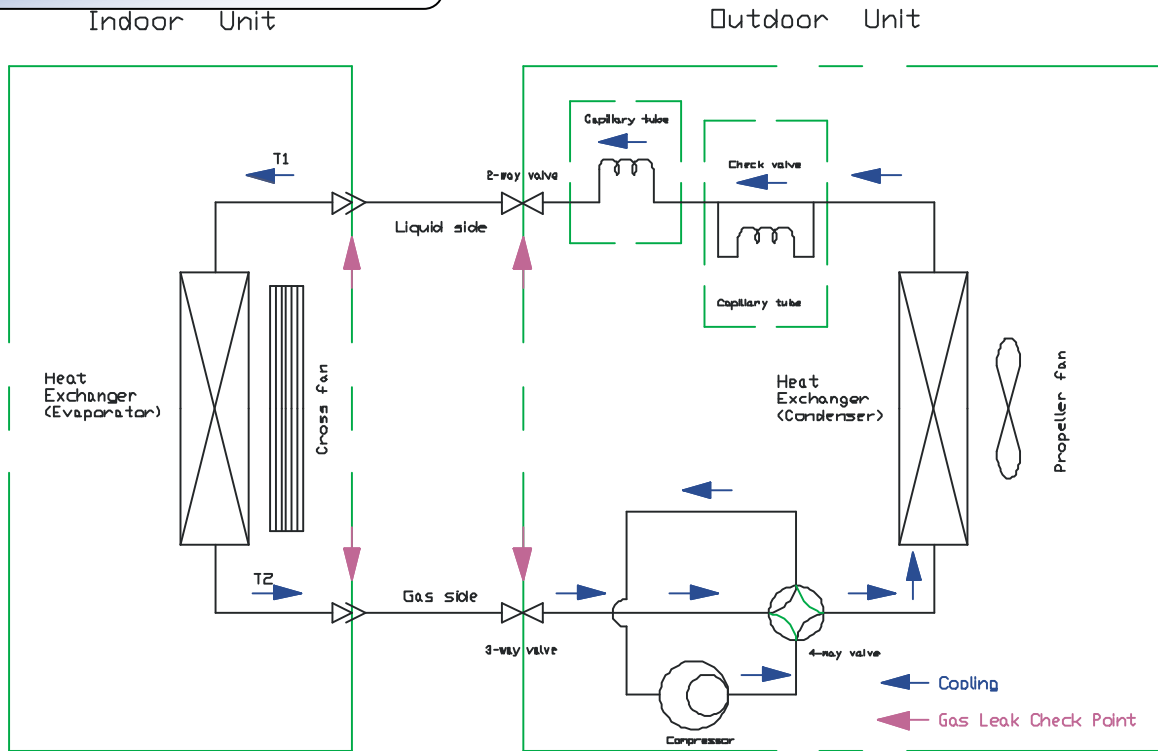

Cooling Cycle

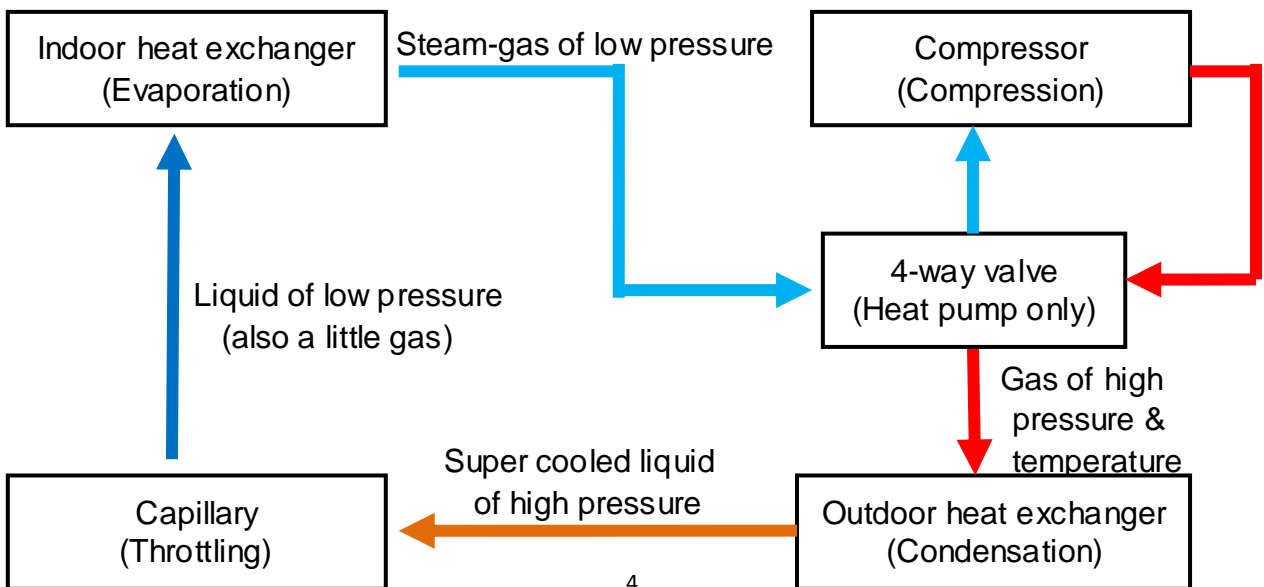

Heating Mode

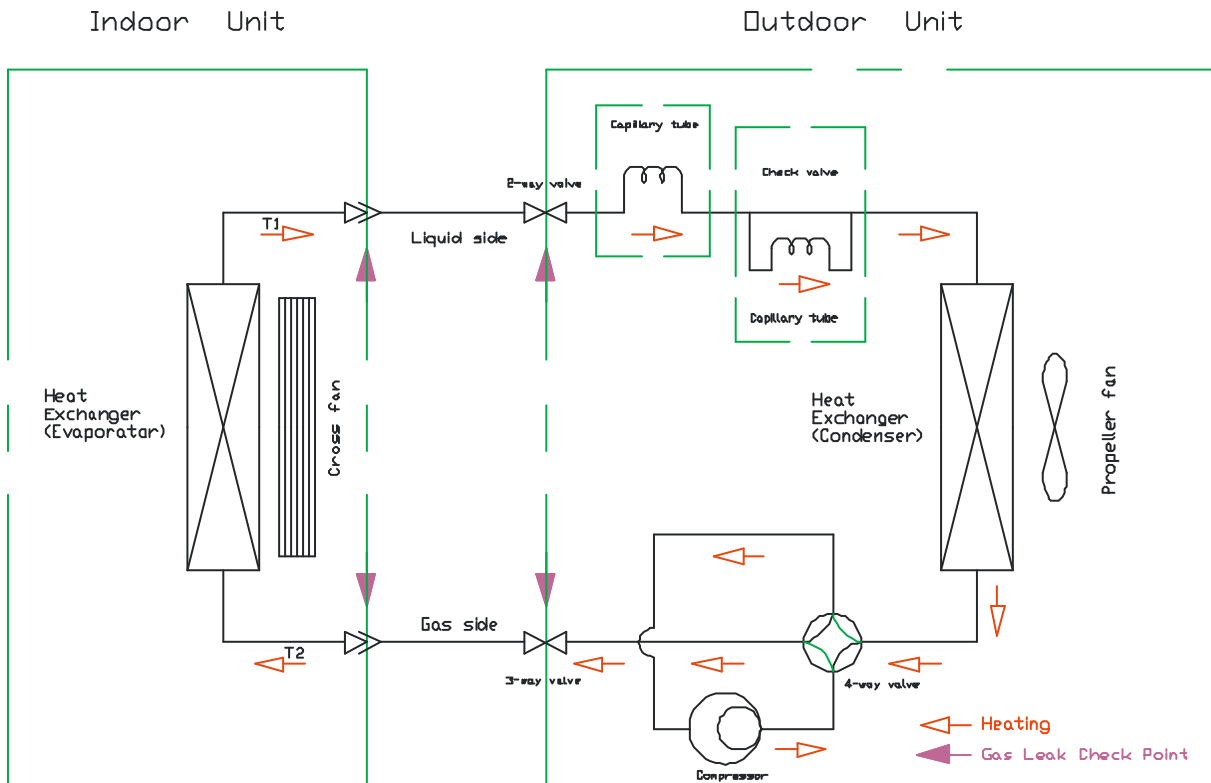

Heating Cycle

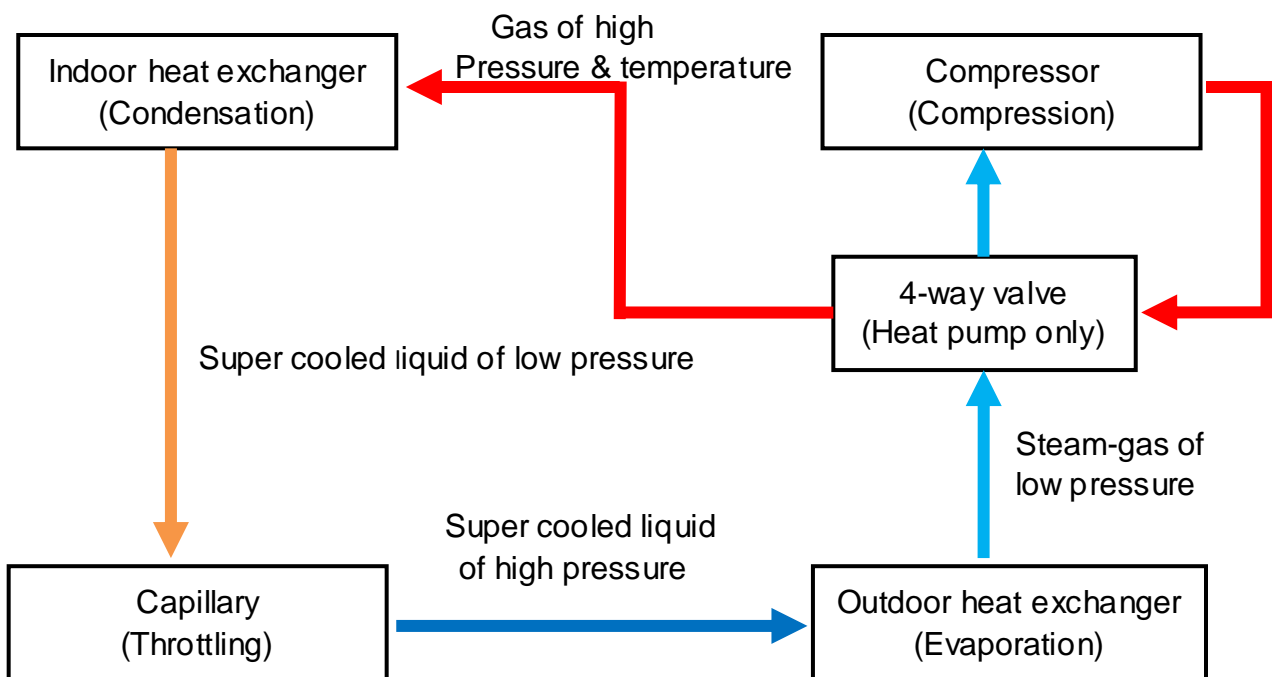

Chapter 3 Wiring Diagram

Electric chart for 09/12/18/24K

Indoor unit

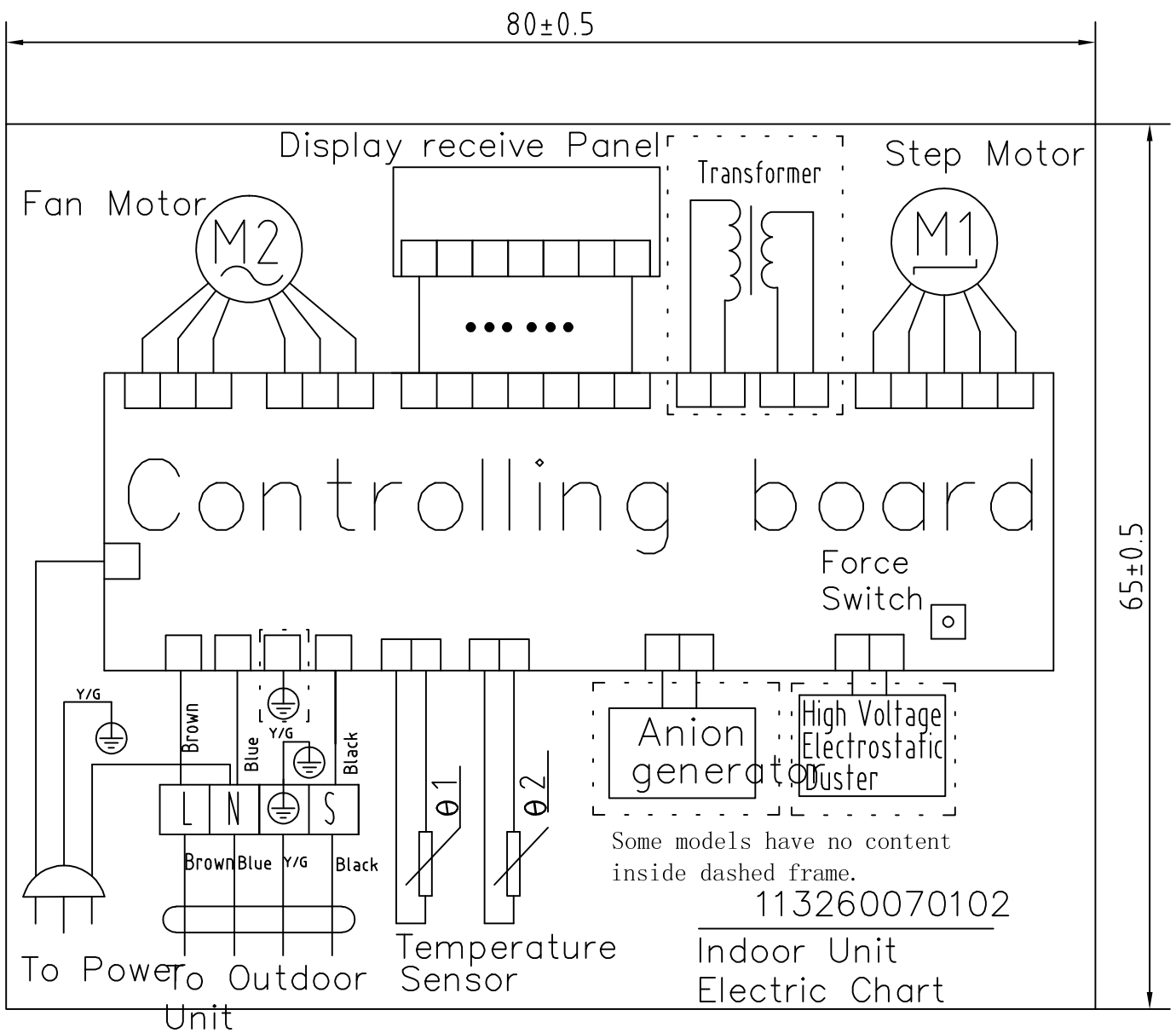

Outdoor unit

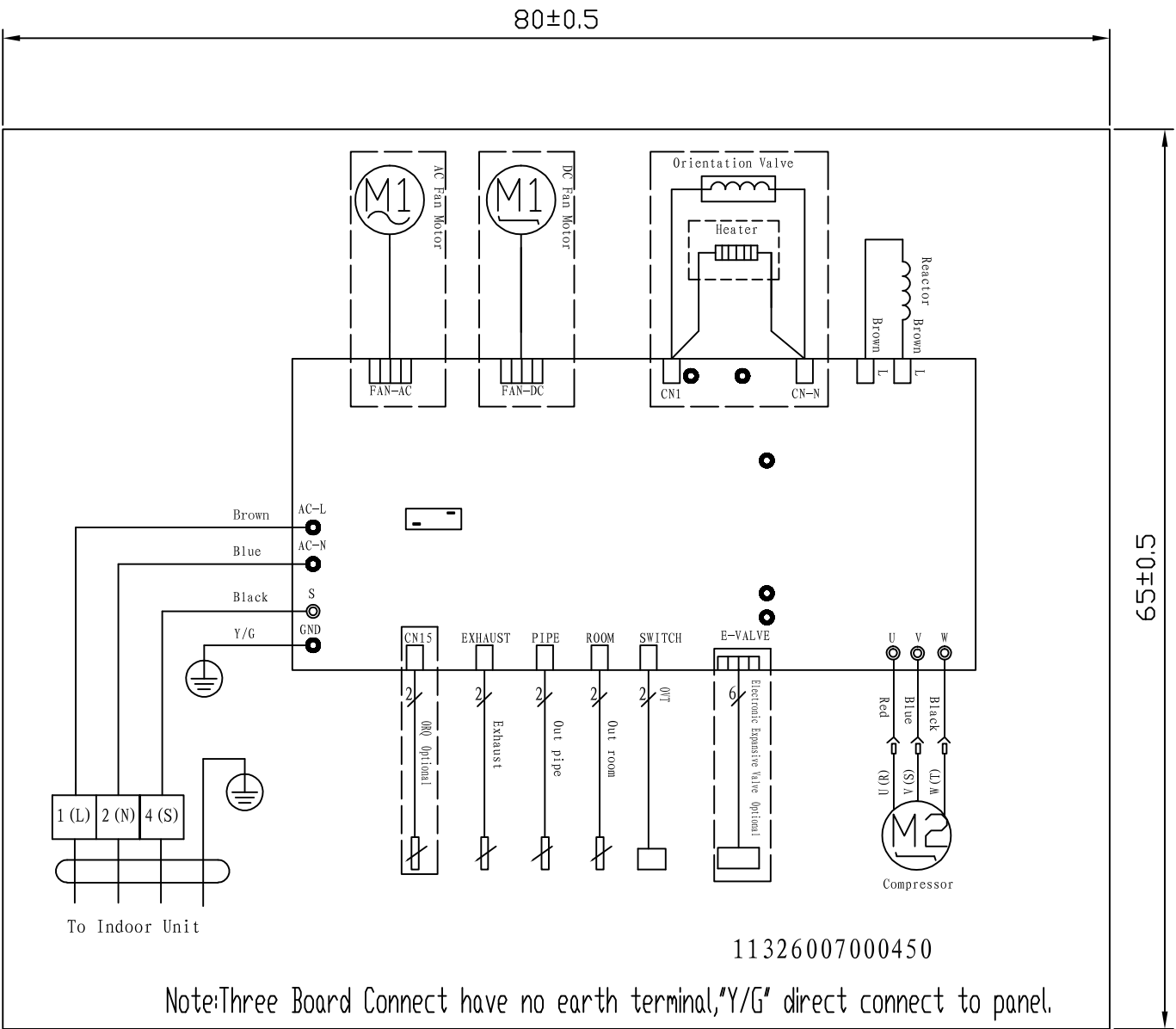

Chapter 5 Troubleshooting Guide

5.1 Error Code

No.	Error Code	Problem
1	E1	Room temperature sensor fault
2	E2	Outdoor coil temperature sensor fault
3	E3	Indoor coil temperature sensor fault
4	E4	indoor fan motor or DC motor feedback fault
5	E5	indoor & outdoor communication fault
6	F0	Outdoor DC Fan motor fault
7	F1	IPM modular fault
8	F2	PFC modular fault
9	F3	Compressor operation fault
10	F4	Exhaust Temperature sensor fault
11	F5	Compressor top cover protection
12	F6	Outdoor ambient temp sensor fault
13	F7	Over/under voltage protection
14	F8	Outdoor modular communication fault
15	F9	Outdoor E ² PROM fault
16	FA	Suction temperature sensor fault

5.2 Troubleshooting Guide for 09-12K

1. The Foremost Inspecting Items

(1)The input voltage must be within +10% tolerance of the rated Voltage. If it is not the case, the air-conditioner will probably not work normally.

(2)Check the connecting cord between indoor unit and outdoor unit to see if it is properly connected. The connecting must be done according to the wiring diagram, please also notice that even different models may have the connecting cord of the same specification.

Please check if the marks at the connecting terminal and the marks on the cord can match, otherwise, the air-conditioner will not work normally.

(3)If the following phenomena are found, the problem is not from the air-conditioner itself.

NO.	Problems	Causes
1	The motor is heard operating but the air-conditioner dose not work when the indoor unit is powered on	Since the air-conditioner is powered on, it will come to working condition as long as you press the ON/OFF button of the remote control and the Signal is well received.
2	The compressor stops running but the indoor fan motor keeps working when it is at cooling mode with the indoor temperature higher than set temperature.	If you turn off the air-conditioner and restart it immediately, it will return to normal in 3 minutes, after that, the air-conditioner will automatically adjust the indoor fan speed to what you set.
3	The compressor works discontinuously at dehumidifying mode.	The air-conditioner will automatically control the working of the compressor according to the inside temperature
4	The air-conditioner does not work while the LED display is on.	The TIMER is set with the air-conditioner; it will be in hold on condition. If the TIMER setting is cancelled, the air-conditioner will return to normal working condition
5	The compressor works discontinuously at cooling and dehumidifying mode, and the indoor fan motor slows down.	The compressor stops internally or the fan motor slows down to prevent the indoor heat exchanger from being frozen.

2. No Power Display

(1) Items

- a) Check if the input voltage is correct?
- b) Check if the AC power supply connecting is correct?
- c) Check if the output voltage of the manostat L7805 (IC2) is correct?

(2) Trouble shooting procedure

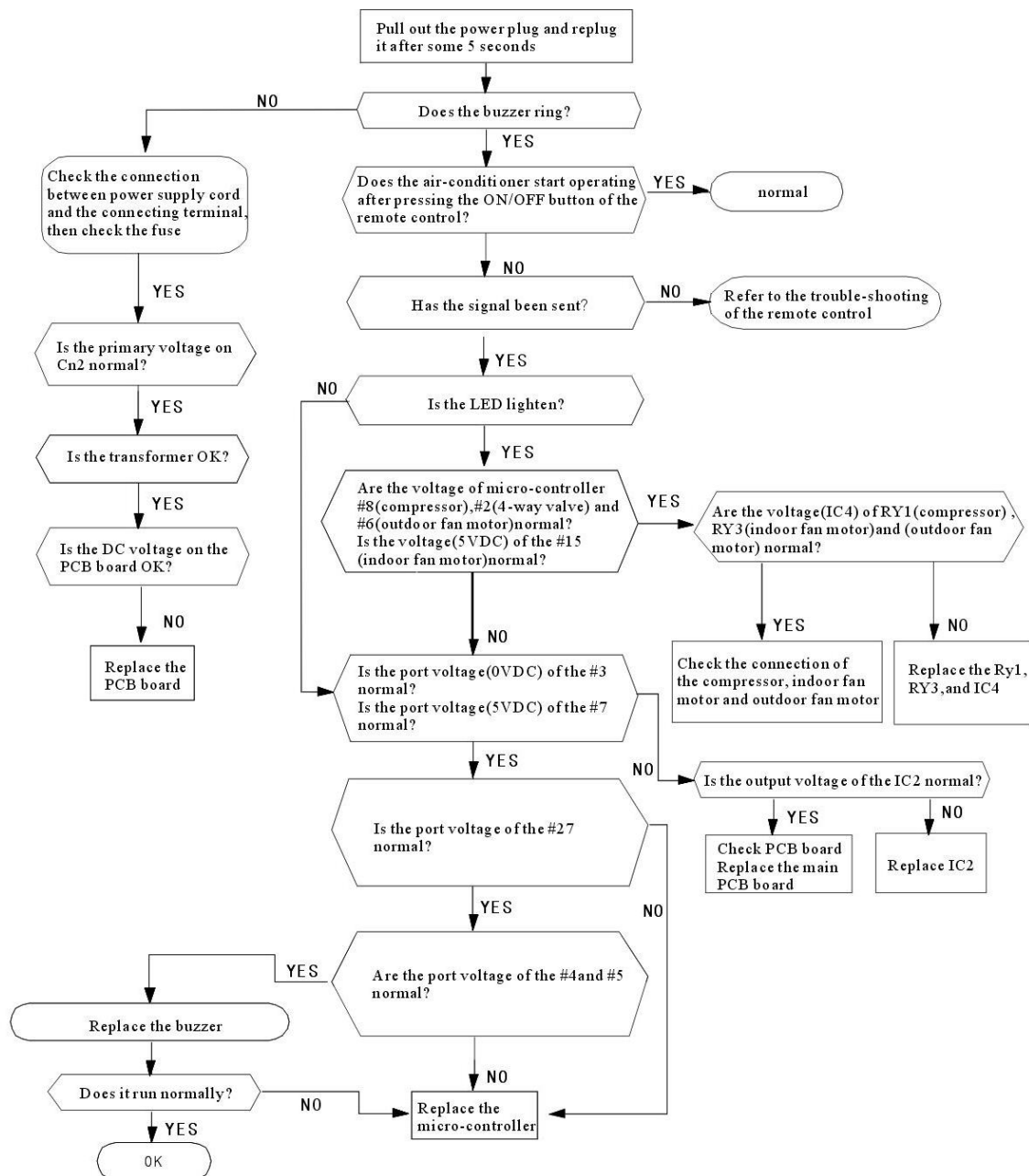

3. The Indoor Fan Motor Does Not Work

(1)Items

- a) Check if the indoor fan motor is connected correctly to the connector (CN8)?
- b) Check if the AC input voltage is correct?
- c) Check if the IC of indoor fan motor is connected correctly to the connector (CN2)?

(CN2)?

- d) Check if the capacity of indoor fan motor is connected correctly to the connector (CN8)?

(2)Trouble shooting procedure

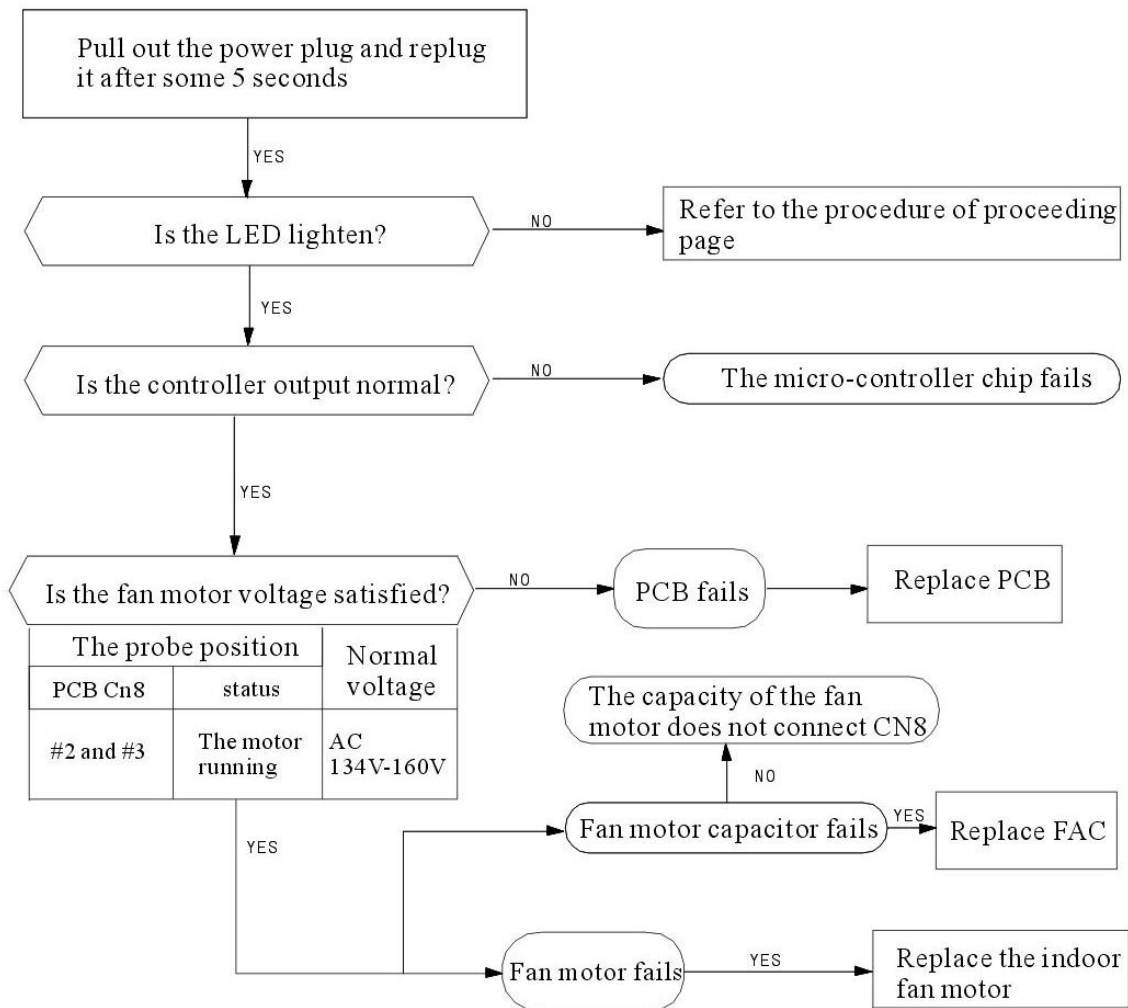

4. The Outdoor Unit Does Not Work

(1) Items

- a) Check if the input voltage is correct?
- b) Check if the wire connection of the outdoor connecting terminal is correct?

(2) Trouble shooting procedure

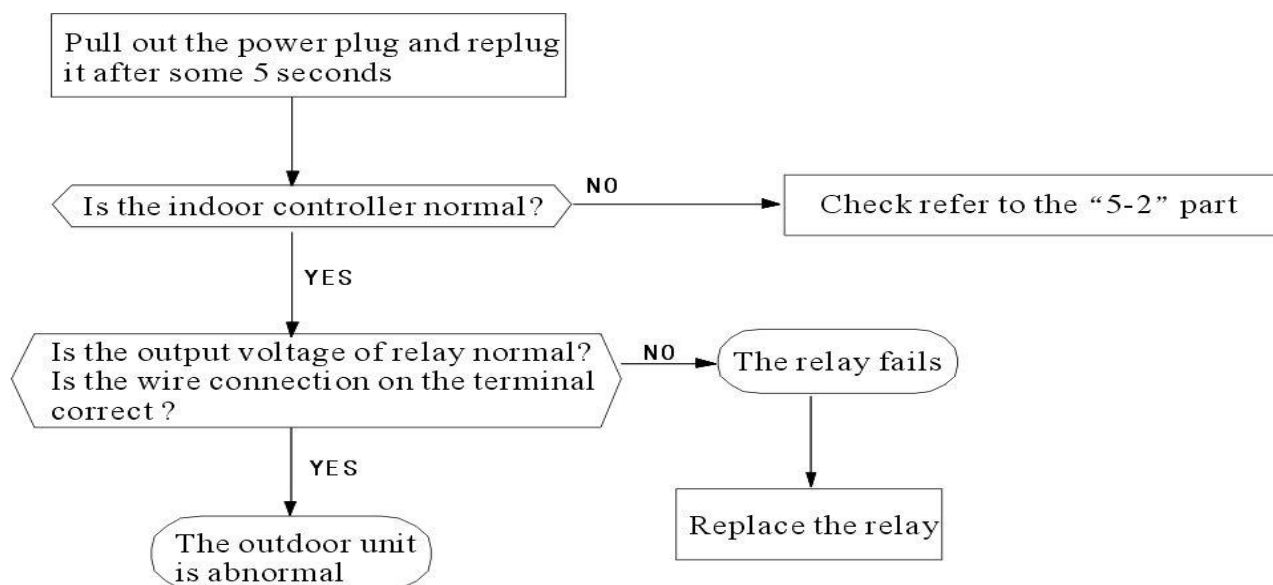

5. The Step Motor Does Not Work

(1)Items

a) Check if the input voltage is correct?

b) Check if the step motor controlling the up-down movement firmly connected to Cn2?

(2)Trouble shooting procedure

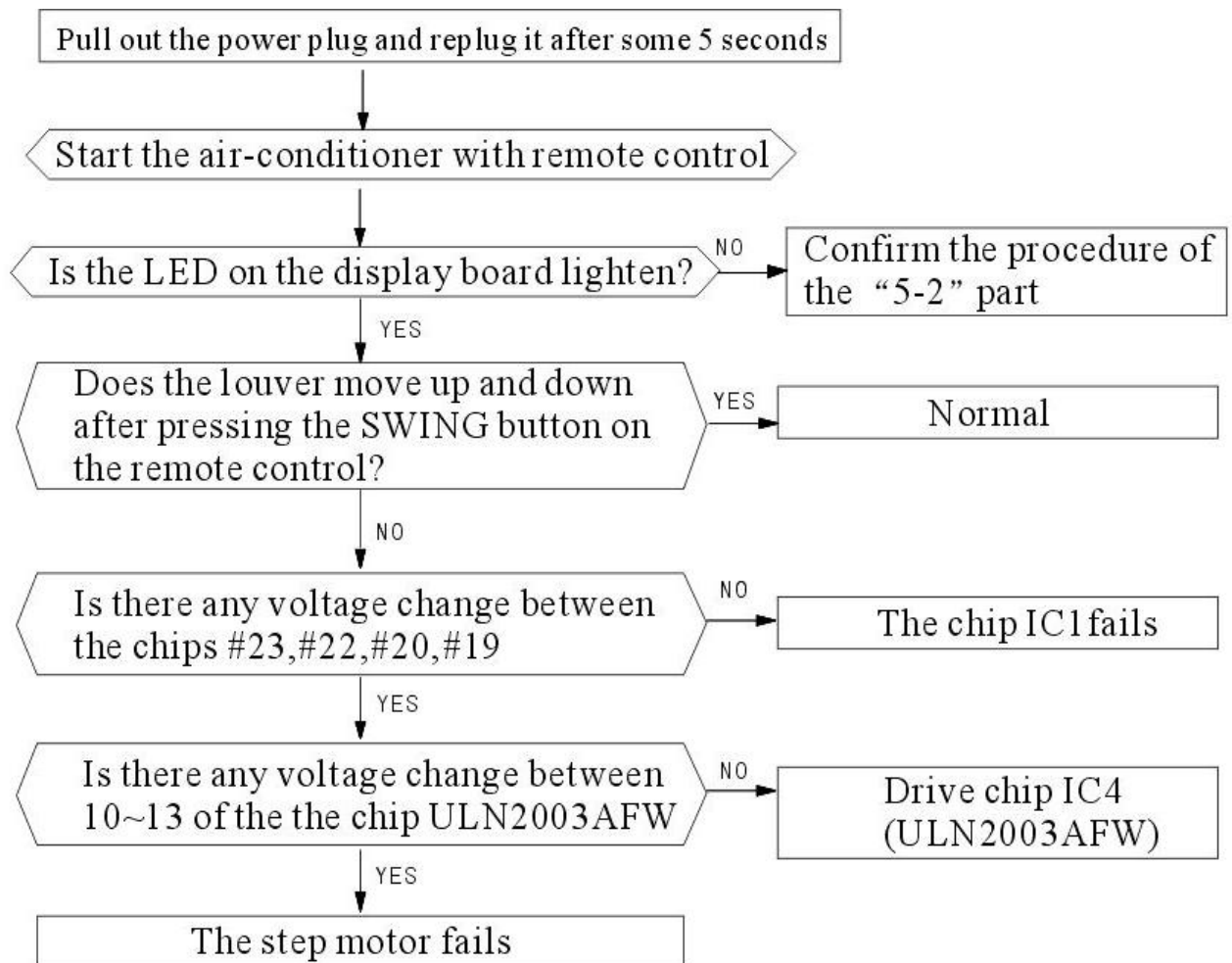

6. Heating Mode Can Work, But No Hot Air Blow

(1) Check if the set temperature is lower than the indoor temperature?

(2) Check if the indoor PCB is connected to the terminal correctly?

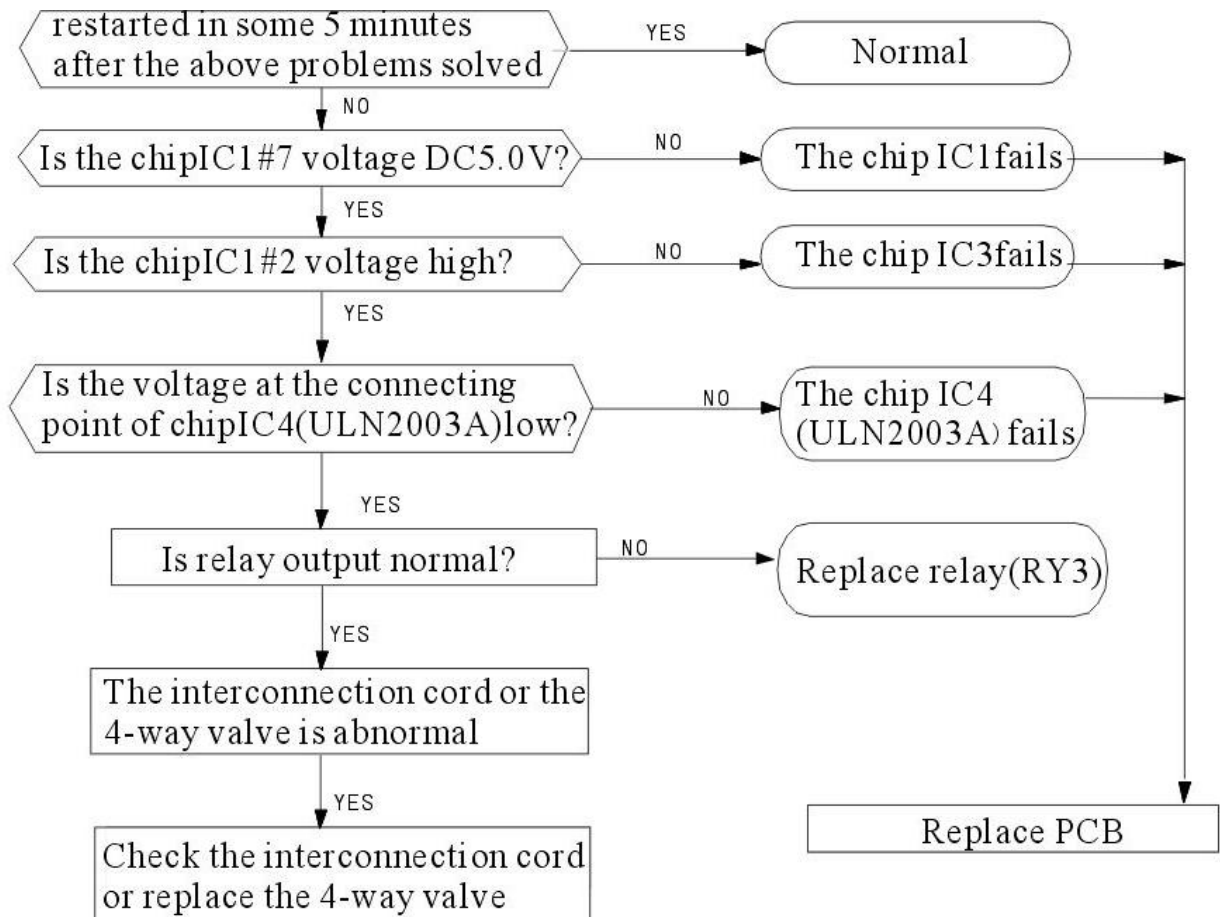

7. Remote Control Can Not Work

Trouble shooting rocedure

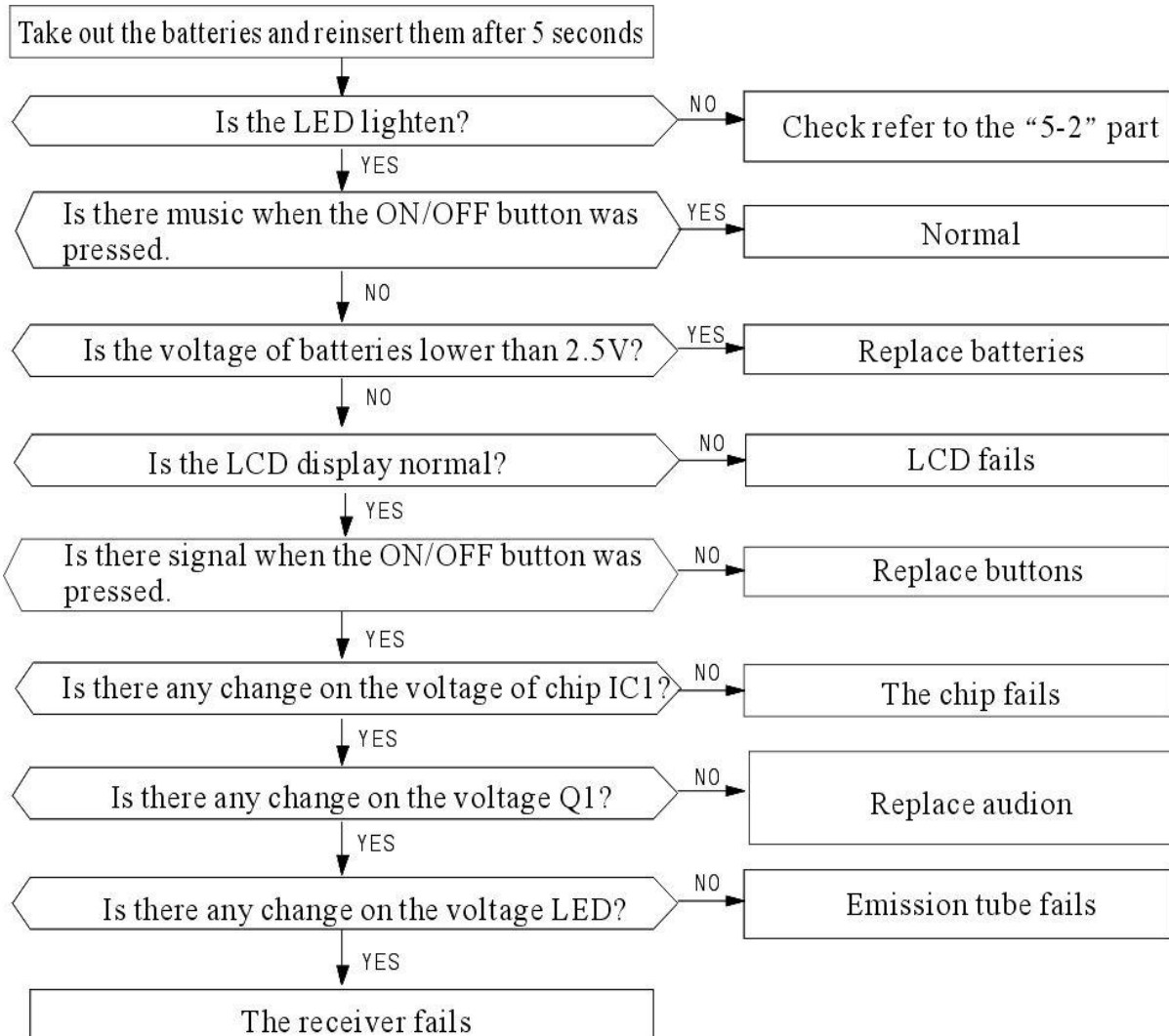

8. The Failure Analysis of the Main Parts

Part	Analysis																										
Heat exchanger	Measure resistance																										
	Normal	<table border="1"> <thead> <tr> <th>Environment temperature</th> <th>15℃</th> <th>20℃</th> <th>25℃</th> <th>30℃</th> <th>35℃</th> <th>40℃</th> </tr> </thead> <tbody> <tr> <td>Resistance of transformer(KΩ)</td> <td>7.45</td> <td>6.08</td> <td>5</td> <td>4.13</td> <td>3.43</td> <td>2.86</td> </tr> </tbody> </table>	Environment temperature	15℃	20℃	25℃	30℃	35℃	40℃	Resistance of transformer(KΩ)	7.45	6.08	5	4.13	3.43	2.86											
		Environment temperature	15℃	20℃	25℃	30℃	35℃	40℃																			
Resistance of transformer(KΩ)	7.45	6.08	5	4.13	3.43	2.86																					
Abnormal	∞ : Turn-off ; 0 Ω : Short-cut																										
The indoor fan motor	Detecting the resistance between each connecting terminal																										
	Normal	Environment temperature (10℃ ~30℃) <table border="1"> <thead> <tr> <th colspan="2">Between</th> <th>1</th> <th>2</th> <th>3</th> </tr> </thead> <tbody> <tr> <td>Blue、yellow</td> <td>Main</td> <td>410 Ω ±10%</td> <td>350 Ω ±10%</td> <td>370 Ω ±10%</td> </tr> <tr> <td>Blue、red</td> <td>Auxiliary</td> <td>325 Ω ±10%</td> <td>270 Ω ±10%</td> <td>300 Ω ±10%</td> </tr> <tr> <td colspan="2">Input</td> <td colspan="3">YYK13-4: 13W YYK19-4: 19W</td> </tr> </tbody> </table>	Between		1	2	3	Blue、yellow	Main	410 Ω ±10%	350 Ω ±10%	370 Ω ±10%	Blue、red	Auxiliary	325 Ω ±10%	270 Ω ±10%	300 Ω ±10%	Input		YYK13-4: 13W YYK19-4: 19W							
		Between		1	2	3																					
		Blue、yellow	Main	410 Ω ±10%	350 Ω ±10%	370 Ω ±10%																					
		Blue、red	Auxiliary	325 Ω ±10%	270 Ω ±10%	300 Ω ±10%																					
Input		YYK13-4: 13W YYK19-4: 19W																									
Abnormal	∞ : Turn-off ; 0 Ω : Short-cut																										
Detecting the voltage between the signal wire of fan motor and ground																											
Normal	<table border="1"> <thead> <tr> <th colspan="2">Between</th> <th>Voltage</th> </tr> </thead> <tbody> <tr> <td>Gray、Orange</td> <td></td> <td>0.5V~4.5V</td> </tr> <tr> <td>Yellow、Orange</td> <td></td> <td>5V</td> </tr> </tbody> </table>	Between		Voltage	Gray、Orange		0.5V~4.5V	Yellow、Orange		5V																	
Between		Voltage																									
Gray、Orange		0.5V~4.5V																									
Yellow、Orange		5V																									
Abnormal	voltage<0, voltage>5 is abnormal																										
Step motor	Normal	Environment temperature (10℃ ~30℃) <table border="1"> <thead> <tr> <th colspan="2">Between</th> <th>1</th> <th>2</th> <th>-</th> </tr> </thead> <tbody> <tr> <td colspan="2"></td> <td>24BYJ48</td> <td>35BYJ412B</td> <td>-</td> </tr> <tr> <td>Blue、yellow</td> <td>-</td> <td>Above 300Ω</td> <td>Around 120Ω</td> <td>-</td> </tr> <tr> <td>-</td> <td>-</td> <td>-</td> <td>-</td> <td>-</td> </tr> <tr> <td colspan="2">Input</td> <td>1.5W</td> <td>-</td> <td>-</td> </tr> </tbody> </table>	Between		1	2	-			24BYJ48	35BYJ412B	-	Blue、yellow	-	Above 300Ω	Around 120Ω	-	-	-	-	-	-	Input		1.5W	-	-
		Between		1	2	-																					
				24BYJ48	35BYJ412B	-																					
Blue、yellow		-	Above 300Ω	Around 120Ω	-																						
-	-	-	-	-																							
Input		1.5W	-	-																							
Abnormal	∞ : Turn-off ; 0 Ω : Short-cut																										
The outdoor fan motor	Detecting the resistance between the red wire and every connecting end																										
	Normal	When the temperature is 20℃ ~30℃ ,around 300Ω and 120Ω																									
	Abnormal	∞ : Turn-off ; 0 Ω : Short-cut																									

5.3 Troubleshooting Guide for 18-24K

1. The Foremost Inspecting Items

(1)The input voltage must be within +10% tolerance of the rated Voltage. If it is not the case, the air-conditioner will probably not work normally.

(2)Check the connecting cord between indoor unit and outdoor unit to see if it is properly connected. The connecting must be done according to the wiring diagram, please also notice that even different models may have the connecting cord of the same specification.

Please check if the marks at the connecting terminal and the marks on the cord can match, otherwise, the air-conditioner will not work normally.

(3)If the following phenomena are found, the problem is not from the air-conditioner itself.

NO.	Problems	Causes
1	The motor is heard operating but the air-conditioner dose not work when the indoor unit is powered on	Since the air-conditioner is powered on, it will come to working condition as long as you press the ON/OFF button of the remote control and the signal is well received.
2	The compressor stops running but the indoor fan motor keeps working when it is at cooling mode with the indoor temperature higher than set temperature.	If you turn off the air-conditioner and restart it immediatly, it will return to normal in 3 minutes, after that, the air-conditioner will automatically adjust the indoor fan speed to what you set.
3	The compressor works discontinuously at dehumidifying mode.	The air-conditioner will automatically control the working of the compressor according to the inside temperature
4	The air-conditioner does not work while the LED display is on.	The TIMER is set with the air-conditioner; it will be in hold on condition. If the TIMER setting is cancelled, the air-conditioner will return to normal working condition.
5	The compressor works discontinuously at cooling and dehumidifying mode, and the indoor fan motor slows down.	The compressor stops internally or the fan motor slows down to prevent the indoor heat exchanger from being frozen.

2. No Power Display

(1) Items

- ① Check if the input voltage is correct?
- ② Check if the AC power supply connecting is correct?
- ③ Check if the output voltage of the manostat L7805(IC2) is correct?

(2) Trouble shooting procedure

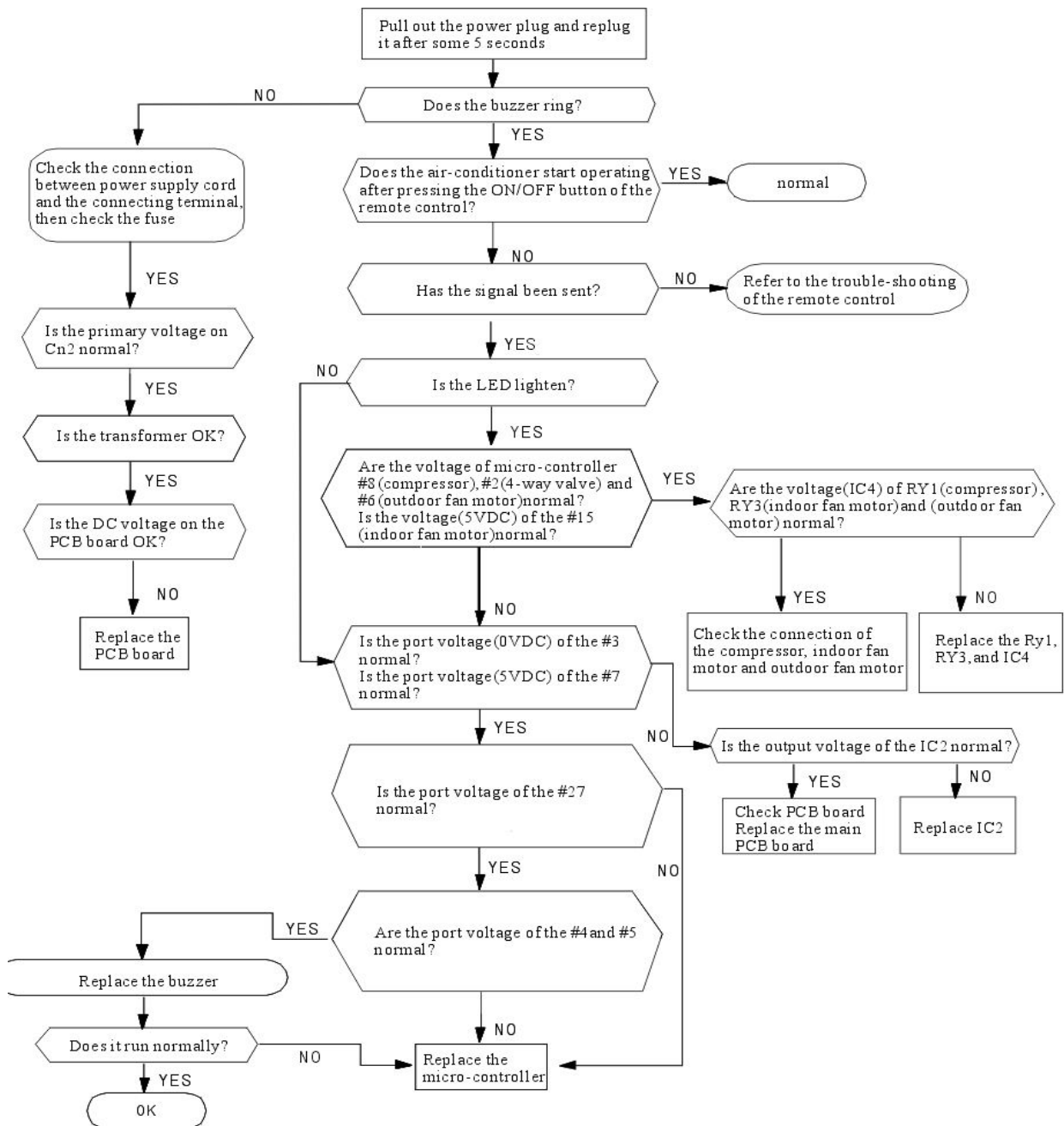

3. The Indoor Fan Motor Does Not Work

(1)Items

- ① Check if the indoor fan motor is connected correctly to the connector(CN8)?
- ② Check if the AC input voltage is correct?
- ③ Check if the IC of indoor fan motor is connected correctly to the connector(CN2)?
- ④ Check if the capacity of indoor fan motor is connected correctly to the connector(CN8)?

(2)Trouble shooting procedure

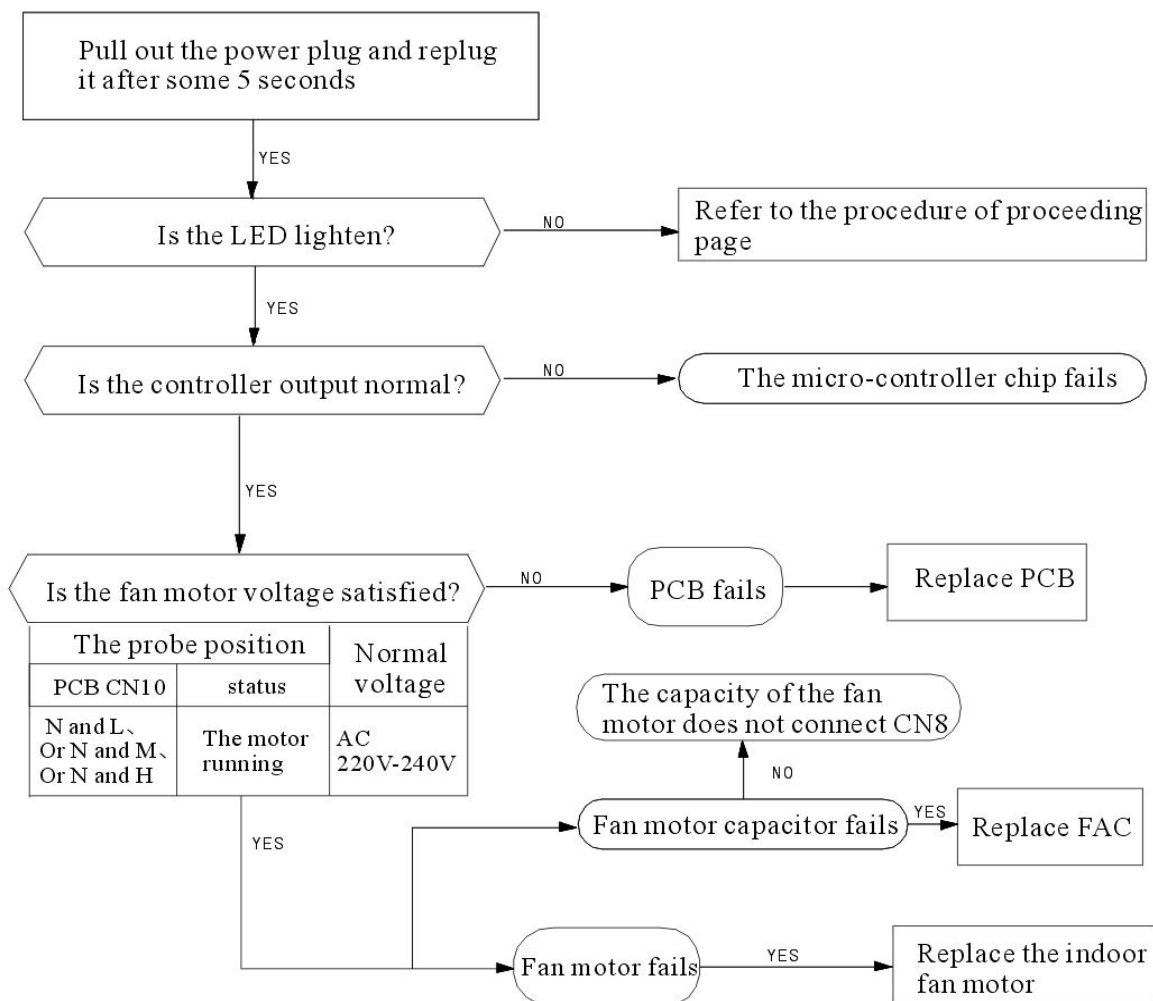

4. The Outdoor Unit Does Not Work

(1) Items

- ① Check if the input voltage is correct?
- ② Check if the wire connection of the outdoor connecting terminal is correct?

(2) Trouble shooting procedure

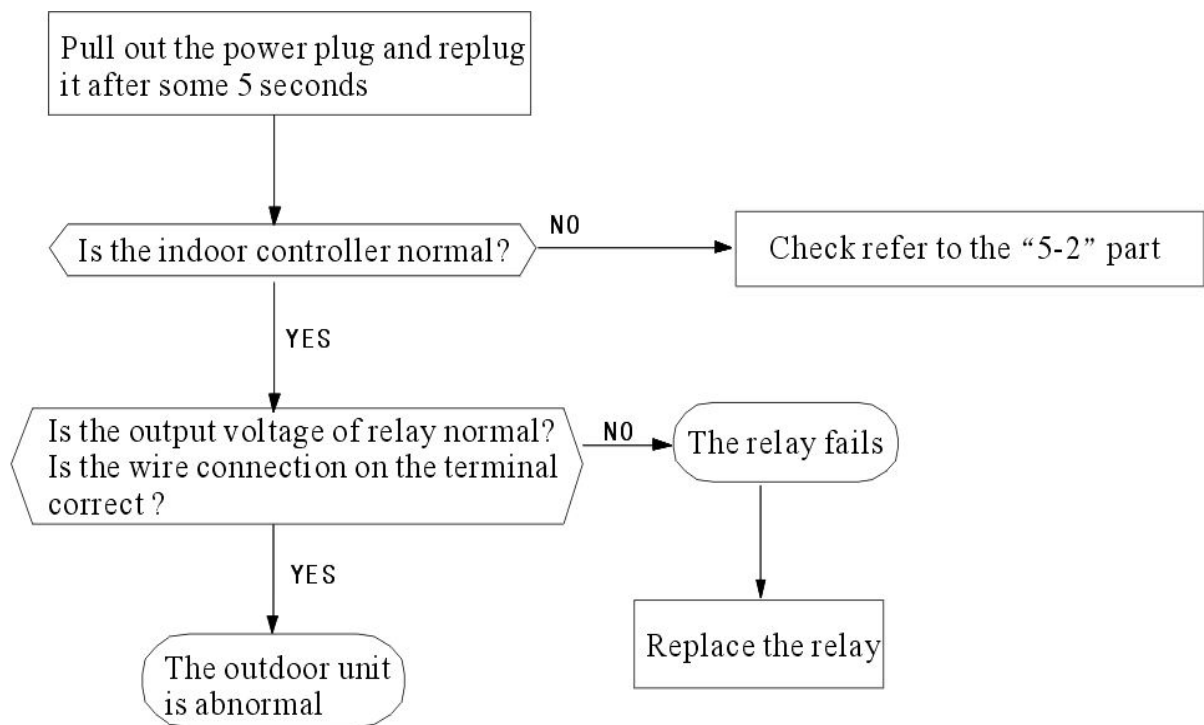

5. The Step Motor Does Not Work

(1)Items

①Check if the input voltage is correct?

②Check if the step motor controlling the up-down movement firmly connected to Cn2?

(2)Trouble shooting procedure

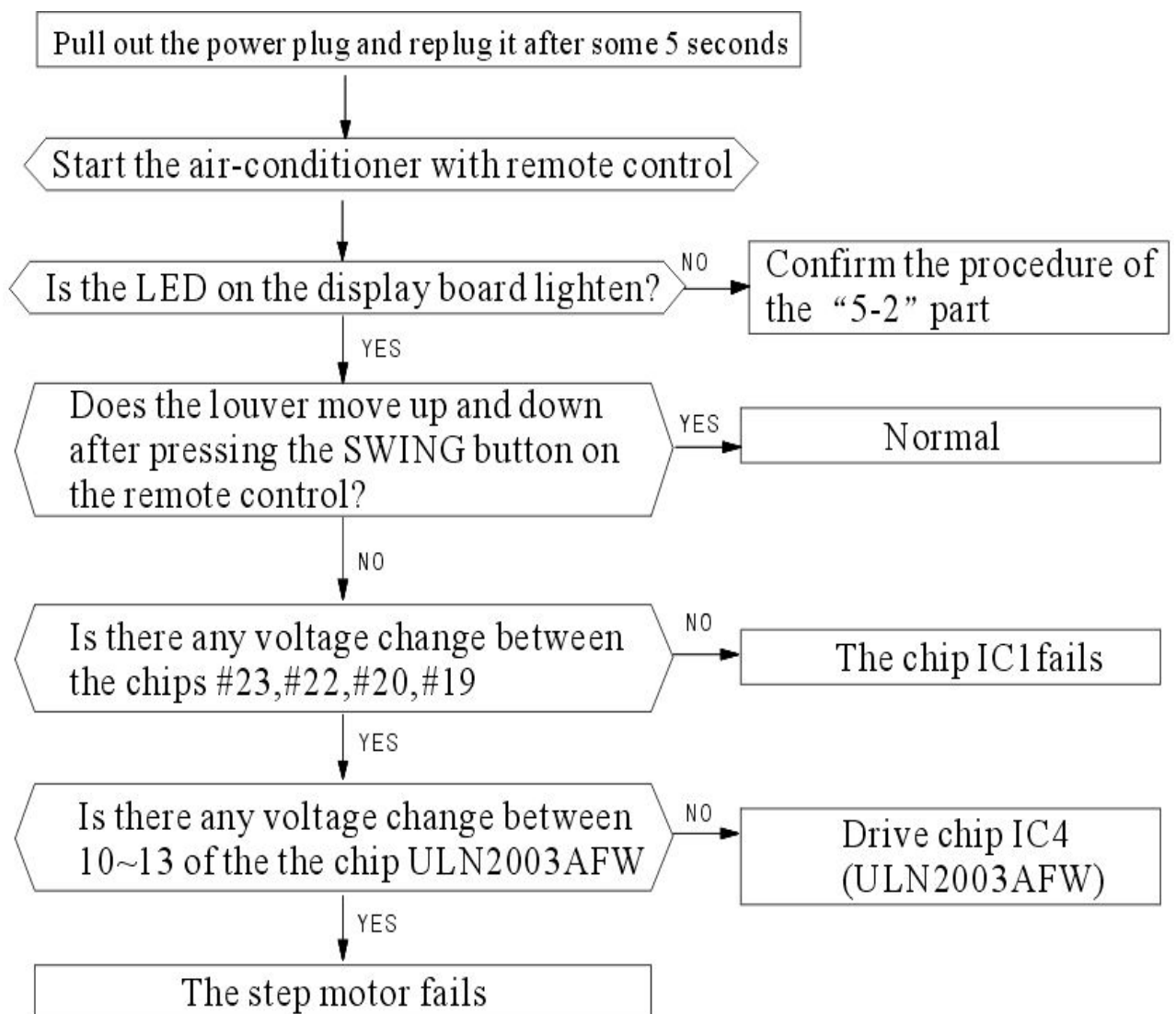

6. Heating Mode Can Work, But No Hot Air Blow

(1) Check if the set temperature is lower than the indoor temperature?

(2) Check if the indoor PCB is connected to the terminal correctly?

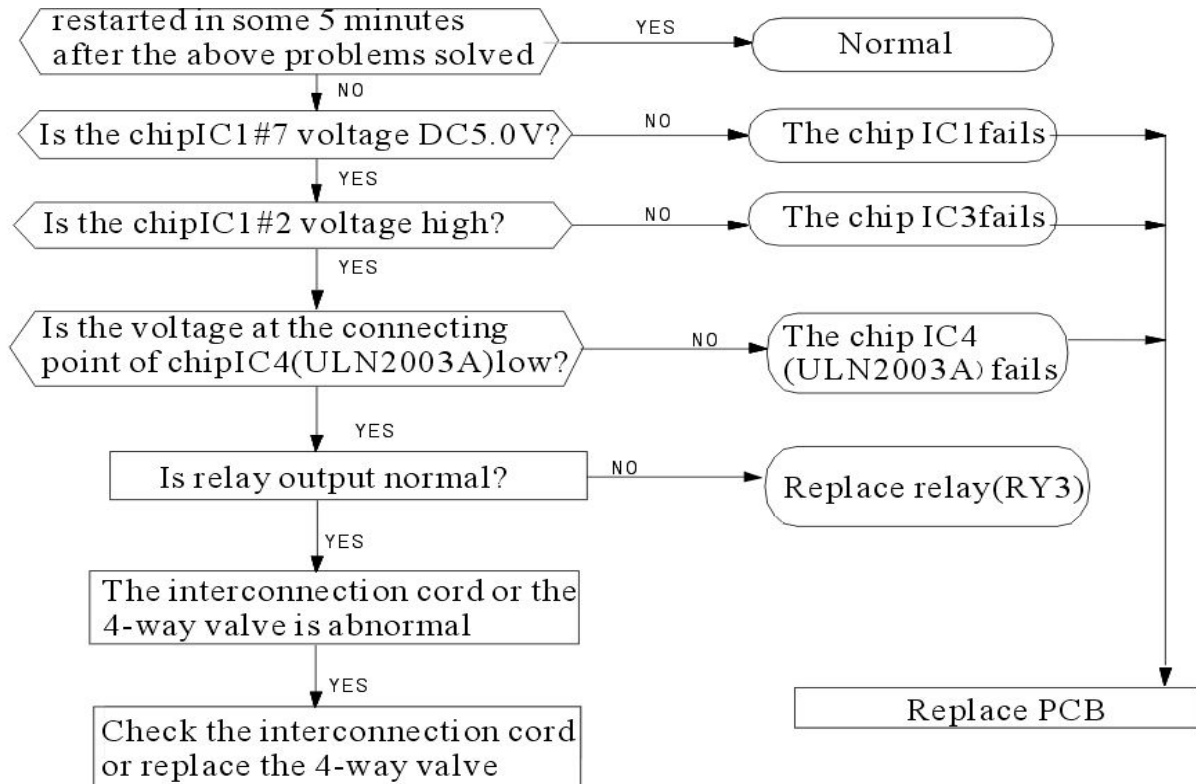

7. Remote Control Can Not Work

Trouble shooting procedure

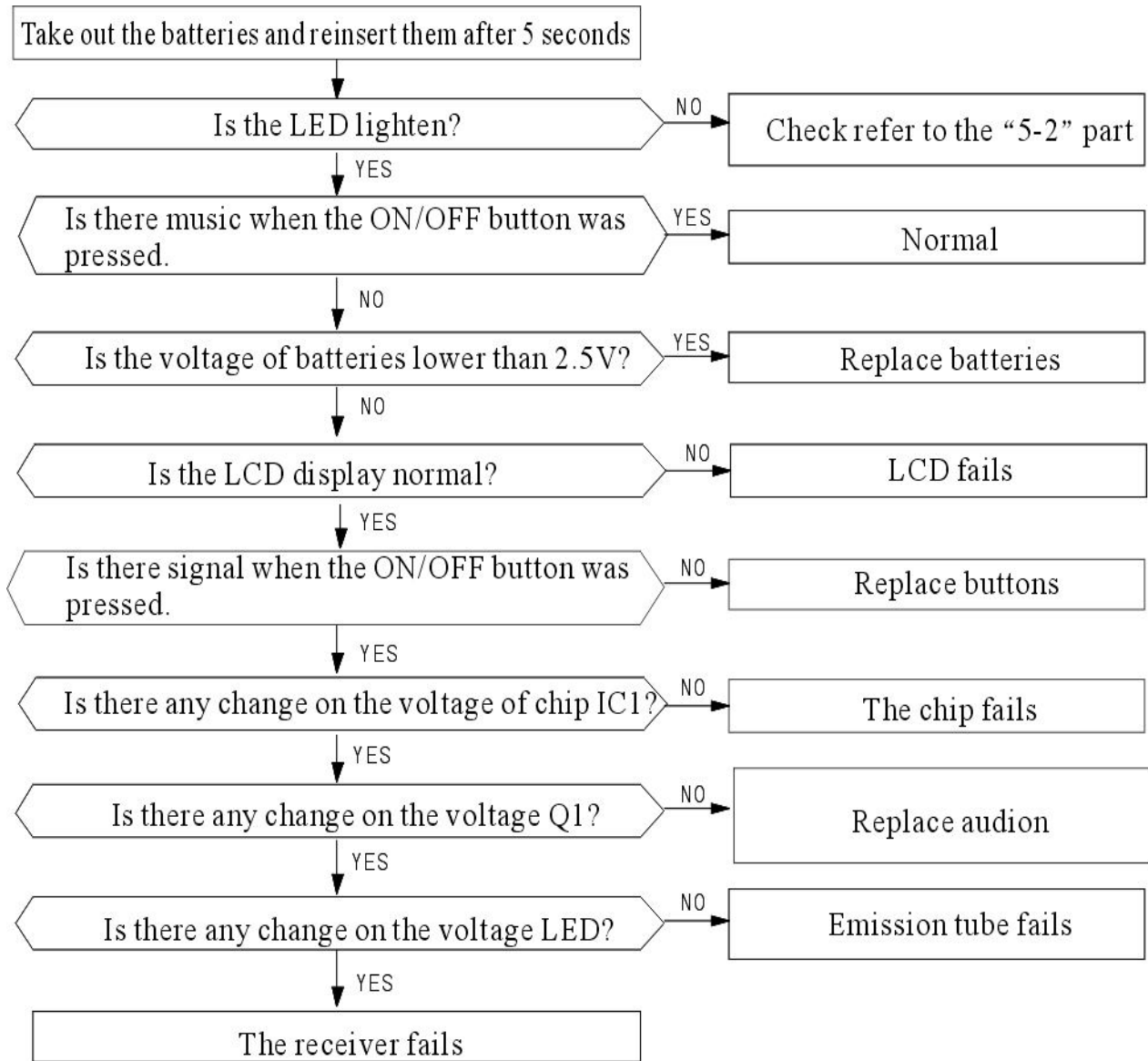

8. The Failure Analysis of the Main Parts

Part	Analysis							
Transformer Heat exchanger	Measure resistance							
	Normal	Environment temperature	15°C	20°C	25°C	30°C	35°C	40°C
		Resistance of transformer(KΩ)	7.45	6.08	5	4.13	3.43	2.86
Abnormal	∞ : Turn-off ; 0Ω : Short-cut							
Step motor	Normal	Environment temperature (10°C ~30°C)						
		Between		1	2	-		
				24BYJ48	35BYJ412B	-		
		Blue, yellow	-	Above300Ω	Around120Ω	-		
		-	-	-	-	-		
Input	1.5W		-	-				
Abnormal	∞ : Turn-off ; 0Ω : Short-cut							
The outdoor fan motor	Detecting the resistance between the red wire and every connecting end							
	Normal	When the temperature is20°C ~30°C ,around 300Ω and 120Ω						
	Abnormal	∞ : Turn-off ; 0Ω : Short-cut						