



Technical Manual

Light Commercial Air Conditioners
(R410a , 50Hz ,T1)



Version:01 2016/01

Content

Part 1. General description	3
Part 2. Indoor unit	6
Part 3 Universal outdoor unit.....	80
Part 4 Trouble shooting.....	112
Part 5 Controller.....	142
Part 6. Sensor resistance table.....	151

Part 1. General description

1.Nomenclature.....	4
2.Unit appearance.....	5

1.Nomenclature

Indoor Unit

A L C A - H 24 / 4 D R 1 H A A

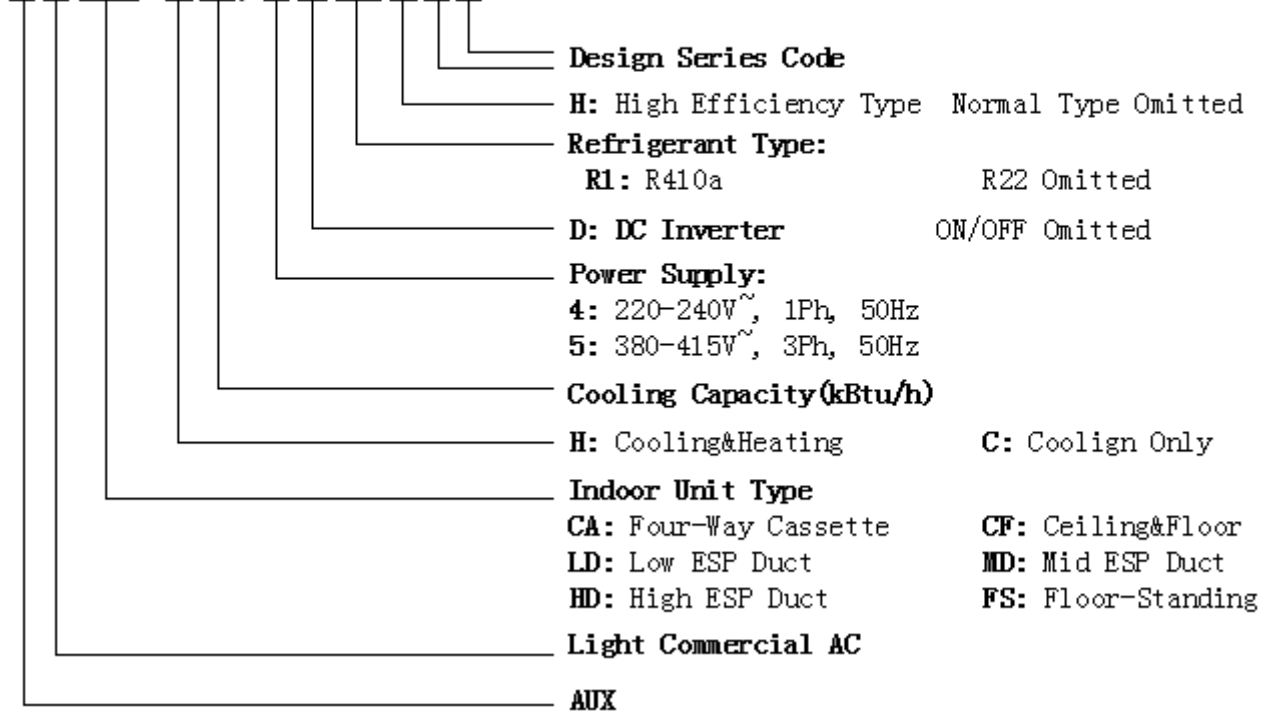





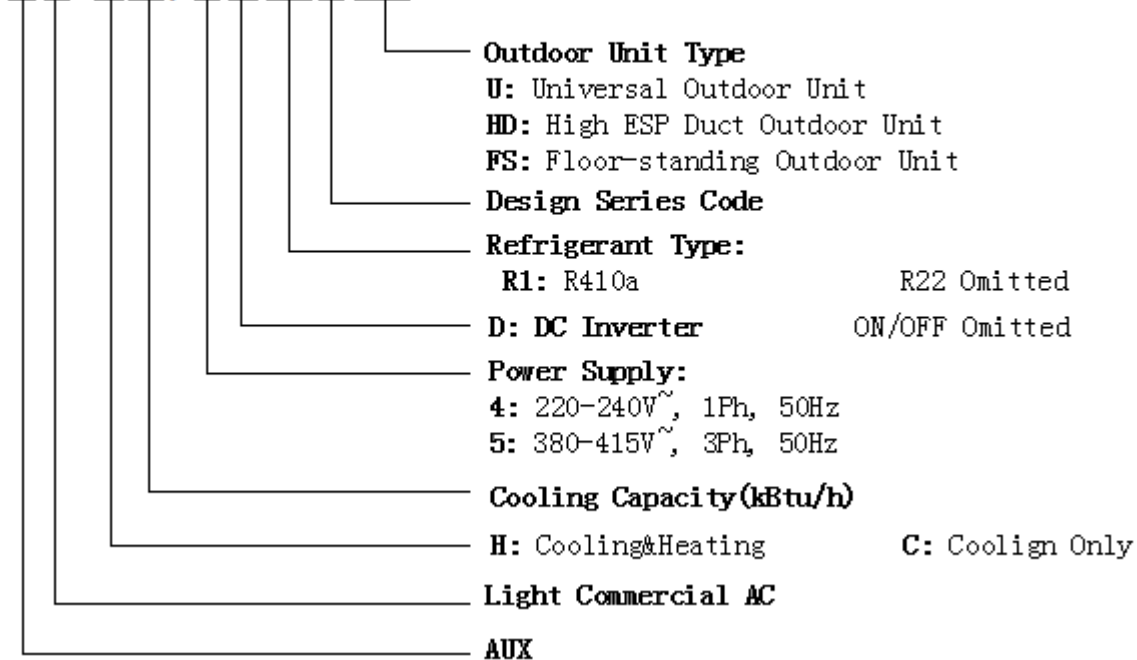



Outdoor Unit

A L - H 24 / 4 D R 1 A (U)



2. Unit appearance

Series	Picture of the indoor unit					
Four-way Cassette						
	12k Btu/h	18k Btu/h	24k Btu/h	36k Btu/h	48k Btu/h	60k Btu/h
Ceiling & Floor						
	18k Btu/h		24k Btu/h	36k Btu/h	48k Btu/h	60k Btu/h
Mid ESP Duct						
	18k Btu/h	24k Btu/h	36k Btu/h	48k Btu/h	60k Btu/h	

Cooling capacity (Btu/h)	12k Btu/h	18 k Btu/h	24 k Btu/h	36 k Btu/h	48 k Btu/h	60 k Btu/h
Universal outdoor unit						

Part 2. Indoor unit

Four-way cassette	7
Ceiling & floor type	33
Middle static pressure duct type	57

Four-way cassette

1.Feature.....	8
2.Specfication	10
3.Capacity Amendment.....	16
4.Demension.....	18
5.Electrical wiring and connection.....	19
6.Installation.....	24
7.Explode view.....	29

1.Feature

Four-way cassette type air conditioner (Cooling-only or heat pump), is installed under the ceiling, compared with Floor & Standing type A/C, it has following advantages: saving room space; Ceiling installation combining with the decoration, makes the room more elegant; Flexible installation in anywhere in the ceiling and 4-direction blowing, makes the indoor temperature is even and makes you feel more comfortable, so Cassette type A/C is a perfect replacing Product of Floor & Standing type A/C.

Application occasions:

Small super market, restaurant, office, meeting room, villa meeting room, family bedroom and so on, and it can even be used as the updating Product for modern residential A/C.

Features:

- ◇ Concealed design, ceiling installation, room space saving, it is very suitable for family or office occasion;
- ◇ With Setting or Auto two operation modes, four-way blowing, strong circulating wind, multi wind speed, the cooling or heating capacity can reach to each corner of the room;
- ◇ One-step formed shell by mold, appearance is elegant;
- ◇ Special insulation design, achieves high heat insulation efficiency, and no condensation on shell;
- ◇ Built-in drain pump, drain-head height is up to 1.2meters, creating the ideal solution for perfect water drainage, also construction and installation is much easier and convenient;
- ◇ Long term air filter, wash period is two times longer than normal filter, and maintenance is free;
- ◇ 3D helix air blade ensures the air flow sufficiently, reduces the unit thickness, and reduces the operation noise greatly;
- ◇ Plastic drip tray adopts innovative foam-PS combined with plastic technical, the thickness of plastic reaches 1mm, avoid any leakage;
- ◇ 6 segments heat exchanger, increase exchanging area, the efficiency of heat exchanging increased by 10%~15%;
- ◇ Ingenious hook design, the panel is convenient to install or remove;
- ◇ Fresh air intake design, leading in fresh air to improve indoor air quality anytime;
- ◇ 3-phase power supply type units with low ambient temperature cooling function, which makes the unit can run normally on the condition that the ambient temperature falls down to -15°C;
- ◇ Auto-restart function;
- ◇ Standard remote controller and optional wired controller;
- ◇ Auxiliary electric heater for heat pump unit, with fast heating and low ambient temperature heating functions;
- ◇ Failure automatic detection, if there is a failure, the indicator will flash and the failure code will display on the wired controller, the failure cause is easier to be found.

Function introduction

Type	Item	ALCA-H**R1AA/AICA-H**R1E				ALCA-H**R1AA		
		12/4	18/4	24/4	36/4	36/5	48/5	60/5
Protection	High pressure protection	—	—	—	—	●	●	●
	Low pressure protection	—	—	—	—	●	●	●
	Compressor overloading protection	●	●	●	●	●	●	●
	High exh. temperate protection	—	—	—	—	●	●	●
	Phase protection (Phase-loss, phase- reverse)	—	—	—	—	●	●	●
	Over-heating protection	●	●	●	●	●	●	●
	Anti-freezing protection	●	●	●	●	●	●	●
	Sensor failure alarm	●	●	●	●	●	●	●
	Failure code display	●	●	●	●	●	●	●
Comfort	Cooling	●	●	●	●	●	●	●
	Heating	●	●	●	●	●	●	●
	3-Speed	●	●	●	●	●	●	●
	Adjustable ESP	—	—	—	—	—	—	—
	Auto-restart(Optional)	●	●	●	●	●	●	●
	Anti-cold wind	●	●	●	●	●	●	●
	Afterheat wind blowing	●	●	●	●	●	●	●
	Timing ON/OFF	●	●	●	●	●	●	●
Operation	Time display	●	●	●	●	●	●	●
	Operation mode display	●	●	●	●	●	●	●
	Fan speed display	●	●	●	●	●	●	●
	Defrost display	●	●	●	●	●	●	●
	Timing ON/OFF display	●	●	●	●	●	●	●
	Wind angle display	●	●	●	●	●	●	●
	Sleeping mode display	●	●	●	●	●	●	●
Running	Auto start	●	●	●	●	●	●	●
	Dehumidifying	●	●	●	●	●	●	●
	Auto defrost	●	●	●	●	●	●	●
	Ventilation function	●	●	●	●	●	●	●
	Low ambient temperature cooling	●	●	●	●	●	●	●
Health	Washable air filter	●	●	●	●	●	●	●
	Fresh air interface	●	●	●	●	●	●	●
Installation	Left/right drainage(optional)	—	—	—	—	—	—	—
	Left/right pipe connection(optional)	—	—	—	—	—	—	—
	Down/back air suction(optional)	—	—	—	—	—	—	—
	Installation indicating board	●	●	●	●	●	●	●

Remarks: ● Stands for “YES”

— Stands for “NO”

2.Specification

Model	Indoor		ALCA-H12/4R1AA	ALCA-H18/4R1AA	ALCA-H24/4R1AA
	Panel		MB13	MB13	MB12
	Outdoor		AL-H12/4R1D(U)	AL-H18/4R1D(U)	AL-H24/4R1D(U)
Factory Model	Indoor		ALCa-H12A4/R1C7-B 7	ALCa-H18A4/R1C7-B7	ALCa-H24B4/R1EB -B7
	Panel		MB13	MB13	MB12
	Outdoor		AL-H12A4/R1(T)-B7	AL-H18A4/R1(T)-B7	AL-H24A4/R1(T)-B7
Code	Indoor		16106022000055	16106022000054	16106022000053
	Panel		16108004000004	16108004000004	16108002000007
	Outdoor		16107022000017	16107022000019	16107022000018
Power Supply		V~,Hz,Ph	220~240,50,1	220~240,50,1	220~240,50,1
Capacity	Cooling	Btu/h	12000	18000	24000
		KW	3.60	5.30	7.20
	Heating	Btu/h	13500	20000	27500
		KW	3.90	5.80	8.08
Electric Data	Rated Cooling Power Input	KW	1.19	1.76	2.39
	Rated Heating Power Input	KW	1.20	1.80	2.50
	Rated Cooling Current	A	5.49	8.08	11.06
	Rated Heating Current	A	5.63	8.27	11.59
Performance	EER	W/W	3.03	3.01	3.01
	COP	W/W	3.25	3.22	3.23
Indoor Fan Motor	Model		YDK25-6E1	YDK30-6E1	XD30A
	Brand		WELLING/Sinjun	WELLING/Sinjun	WELLING/Sinjun
	Output Power x Fan quantity	W	25*1	30*1	30*1
	Capacitor	uF	1.5	2.5	2.5
	Speed (Hi/Mi/Lo)	r/min	850/750/650	920/850/750	500/430/320
Indoor Coil	Number Of Row		2	2	2
	Tube Pitch(a)x Row Pitch(b)	mm	20.5x12.7	20.5x12.7	20.5x12.7
	Fin Pitch	mm	1.5	1.5	1.4
	Fin Material		Hydrophillic aluminum fin		
	Tube Outside Dia.and Material	mm	φ7 , Inner grooved	φ7 , Inner grooved	φ7 , Inner grooved
	Coil Length x Height x Width	mm	1160x184.5x25.4	1160x184.5x25.4	2142x205x25.4
	Heat Exchanging Area	m ²	4.32	5.76	11.34
Indoor Unit	Indoor Air Flow (Hi/Mi/Lo)	m ³ /h	620/496/434	900/720/630	1300/1040/910
	Noise Level(Hi/Mi/Lo)	dB(A)	41/38/32	41/38/32	45/42/36

	Net Dimension (W*H*D)	mm	615x615x263	615x615x263	835x835x250
	Packing Dimension (W*H*D)	mm	700x700x330	700x700x330	910x910x310
	Net Weight	Kg	17.5	18	24
	Gross Weight	Kg	21.5	22	27.5
Panel	Net Dimension (W*H*D)	mm	650x650x55	650x650x55	950x950x55
	Packing Dimension (W*H*D)	mm	700x700x330	700x700x330	1000x1000x100
	Net weight	Kg	3	3	5
	Gross weight	Kg	5	5	7
Refrigerant Pipe	Liquid Side	mm	6.35	6.35	9.52
	Gas Side	mm	12.7	12.7	15.88
	Max. Refrigerant Pipe Length	m	15	20	30
	Max. Difference In Level	m	10	15	15
Operation Temperature Range		°C	16~32	16~32	16~32
Ambient Temperature Range(Cooling/Heating)		°C	-15~-49/-15~24	-15~-49/-15~24	-15~-49/-15~24
Application Area		m ²	13-21	21-35	28-47
Connection Wiring	Power Wiring(Indoor)	mm ²	3x2.5mm ²	3x4mm ²	/
	Power Wiring(Outdoor)	mm ²	/	/	3x6mm ²
	Signal Wiring	mm ²	3x2.5mm ² +2x1mm ²	3x2.5mm ² +2x1mm ²	3x2.5mm ² +3x1mm ²
Wireless Remote Controller			YKR-K/001E	YKR-K/001E	YKR-K/001E
Qty'per 20'& 40'&40HQ(Only For Reference)		Set	66/137/161	66/137/161	42/82/92

Note:

1. Working condition of the cooling capacity measured: Inside the room DB temperature 27°C,WB temperature19°C;Outside of the room DB temperature 35°C,WB temperature 24°C;Working condition of the heating capacity measured:Inside the room DB temperature 20°C,Outside of the room DB temperature 7°C,WB temperature 6°C.
2. Parameters above are all measured when the connecting pipe is 5 meters.
3. Parameters above may be modified as product improvement. We keep the right to change the product specifications without prior notice, please take the parameters listed on the nameplate as criterion.

Model	Indoor		ALCA-H36/5R1AA	ALCA-H48/5R1AA	ALCA-H60/5R1AA
	Panel		MB12	MB12	MB12
	Outdoor		AL-H36/5R1D(U)	AL-H48/5R1D(U)	AL-H60/5R1D(U)
Factory Model	Indoor		ALCa-H36A5/R1EB-B7	ALCa-H48A5/R1EB-B7	ALCa-H60A5/R1EB-B7

	Panel		MB12	MB12	MB12
	Outdoor		AL-H36A5/R1(T)-B7	AL-H48A5/R1(T)-B7	AL-H60A5/R1(T)-B7
Code	Indoor		16106022000056	16106022000057	16106022000058
	Panel		16108002000007	16108002000007	16108002000007
	Outdoor		16107022000020	16107022000022	16107022000023
Power Supply		V~,Hz,Ph	380~415,50,3	380~415,50,3	380~415,50,3
Capacity	Cooling	Btu/h	36000	48000	60000
		KW	10.60	14.00	17.60
	Heating	Btu/h	40000	53000	63500
		KW	11.70	15.50	18.50
Electric Data	Rated Cooling Power Input	KW	3.77	4.87	5.71
	Rated Heating Power Input	KW	3.50	5.13	6.00
	Rated Cooling Current	A	6.76	8.88	10.42
	Rated Heating Current	A	6.28	9.33	10.88
Performance	EER	W/W	2.81	2.87	3.08
	COP	W/W	3.34	3.02	3.08
Indoor Fan Motor	Model		YDK45-6Q	XD80A	XD80A
	Brand		WELLING/Sinjun	WELLING/Sinjun	WELLING/Sinjun
	Output Power x Fan quantity	W	45*1	80*1	80*1
	Capacitor	uF	3	3	4
	Speed (Hi/Mi/Lo)	r/min	650/520/450	695/585/495	695/585/495
Indoor Coil	Number Of Row		2	2	3
	Tube Pitch(a)x Row Pitch(b)	mm	20.5x12.7	20.5x12.7	20.5x12.7
	Fin Pitch	mm	1.4	1.4	1.4
	Fin Material		Hydrophilic aluminum fin		
	Tube Outside Dia.and Material	mm	φ7, Inner grooved	φ7, Inner grooved	φ7, Inner grooved
	Coil Length x Height x Width	mm	2142x205x25.4	2142x246x25.4	2142x246x25.4
	Heat Exchanging Area	m ²	12.76	15.60	15.60
Indoor Unit	Indoor Air Flow (Hi/Mi/Lo)	m ³ /h	1500/1200/1050	1800/1440/1260	1800/1440/1260
	Noise Level(Hi/Mi/Lo)	dB(A)	48/45/39	50/47/41	50/47/41
	Net Dimension	mm	835x835x250	835x835x290	835x835x290

	(W*H*D)				
	Packing Dimension (W*H*D)	mm	910×910×310	910×910×350	910×910×350
	Net Weight	Kg	24	26.5	26.5
	Gross Weight	Kg	27.5	30.5	30.5
Panel	Net Dimension (W*H*D)	mm	950×950×55	950×950×55	950×950×55
	Packing Dimension (W*H*D)	mm	1000×1000×100	1000×1000×100	1000×1000×100
	Net weight	Kg	5	5	5
	Gross weight	Kg	7	7	7
Refrigerant Pipe	Liquid Side	mm	9.52	9.52	9.52
	Gas Side	mm	15.88	19.05	19.05
	Max. Refrigerant Pipe Length	m	50	50	50
	Max. Difference In Level	m	30	30	30
Operation Temperature Range		°C	16~32	16~32	16~32
Ambient Temperature Range(Cooling/Heating)		°C	-15~49/-15~24	-15~49/-15~24	-15~49/-15~24
Application Area		m ²	42-70	56-93	64-107
Connection Wiring	Power Wiring(Indoor)	3×4m m ²	3×1mm ²	3×1mm ²	3×1mm ²
	Power Wiring(Outdoor)	5×4m m ²	5×4mm ²	5×4mm ²	5×4mm ²
	Signal Wiring	2×1m m ²	2×1mm ²	2×1mm ²	2×1mm ²
Wireless Remote Controller			YKR-K/001E	YKR-K/001E	YKR-K/001E
Qty'per 20'& 40'&40HQ (Only For Reference)		Set	30/70/79	22/50/55	22/50/55

Note:

1. Working condition of the cooling capacity measured: Inside the room DB temperature 27°C,WB temperature19°C;Outside of the room DB temperature 35°C,WB temperature 24°C;Working condition of the heating capacity measured:Inside the room DB temperature 20°C,Outside of the room DB temperature 7°C,WB temperature 6°C.
2. Parameters above are all measured when the connecting pipe is 5 meters.
3. Parameters above may be modified as product improvement. We keep the right to change the product specifications without prior notice, please take the parameters listed on the nameplate as criterion.

Model	Indoor		ALCA-H36/4R1E
	Panel		MB12
	Outdoor		AL-H36/4R1(U)
Factory Model	Indoor		ALCa-H36A4/R1-E A

	Panel		MB12
	Outdoor		AL-H36A4/R1(T)
Code	Indoor		16106021000005
	Panel		16108002000007
	Outdoor		16107022000001
Power Supply		V~,Hz,Ph	220~240,50,1
Capacity	Cooling	Btu/h	36000
		KW	10.60
	Heating	Btu/h	40000
		KW	11.70
Electric Data	Rated Cooling Power Input	KW	3.77
	Rated Heating Power Input	KW	3.50
	Rated Cooling Current	A	17.3
	Rated Heating Current	A	16.6
Performance	EER	W/W	2.81
	COP	W/W	3.34
Indoor Fan Motor	Model		YDK45-6Q
	Brand		WELLING/Sinjun
	Output Power x Fan quantity	W	45*1
	Capacitor	uF	3
	Speed (Hi/Mi/Lo)	r/min	650/520/450
Indoor Coil	Number Of Row		2
	Tube Pitch(a)x Row Pitch(b)	mm	20.5x12.7
	Fin Pitch	mm	1.4
	Fin Material		louver
	Tube Outside Dia.and Material	mm	φ7, Inner grooved
	Coil Length x Height x Width	mm	2014x205x25.4
	Heat Exchanging Area	m ²	12.18
Indoor Unit	Indoor Air Flow (Hi/Mi/Lo)	m ³ /h	1500/1200/1050
	Noise Level(Hi/Mi/Lo)	dB(A)	48/45/39
	Net Dimension	mm	835x835x250

	(W*H*D)		
	Packing Dimension (W*H*D)	mm	910×910×310
	Net Weight	Kg	24
	Gross Weight	Kg	27.5
Panel	Net Dimension (W*H*D)	mm	950×950×55
	Packing Dimension (W*H*D)	mm	1000×1000×100
	Net weight	Kg	5
	Gross weight	Kg	7
Refrigerant Pipe	Liquid Side	mm	9.52
	Gas Side	mm	15.88
	Max. Refrigerant Pipe Length	m	50
	Max. Difference In Level	m	30
Operation Temperature Range		°C	16~32
Ambient Temperature Range(Cooling/Heating)		°C	-5~49/-15~24
Application Area		m ²	42-70
Connection Wiring	Power Wiring(Indoor)	3×4m m ²	3×4mm ²
	Power Wiring(Outdoor)	5×4m m ²	5×4mm ²
	Signal Wiring	2×1m m ²	2×1mm ²
Wireless Remote Controller			YKR-K/001E
Qty'per 20'& 40'&40HQ (Only For Reference)		Set	30/70/79

Note:

- Working condition of the cooling capacity measured: Inside the room DB temperature 27°C,WB temperature 19°C;Outside of the room DB temperature 35°C,WB temperature 24°C;Working condition of the heating capacity measured:Inside the room DB temperature 20°C,Outside of the room DB temperature 7°C,WB temperature 6°C.
- Parameters above are all measured when the connecting pipe is 5 meters.
- Parameters above may be modified as product improvement. We keep the right to change the product specifications without prior notice, please take the parameters listed on the nameplate as criterion.

3.CapacityAmendment

3.1 Running range

Cooling capacity (Btu/h)	12000	18000	24000	36000	48000	60000
Power supply	220-240V~/50Hz					
Voltage	187~242V					
Room temperature	16~32°C					
Ambient temperature	Cooling	-15~49°C				
	Heating	-15~24°C				

3.2 Amendment coefficient of cooling capacity under different indoor/outdoor DB/WB temperature

Indoor air inlet temperature°C		Outdoor air inlet DB temperature°C							
DB	WB	25	30	35	40	43	45	47	49
23	16	0.98	0.94	0.89	0.85	0.82	0.79	0.74	0.71
25	18	1.05	1	0.95	0.90	0.87	0.82	0.77	0.72
27	19	1.1	1.05	1	0.95	0.91	0.87	0.84	0.79
28	20	1.12	1.07	1.02	0.96	0.93	0.90	0.86	0.81
30	22	1.19	1.13	1.08	1.02	0.99	0.96	0.91	0.88
32	24	1.26	1.20	1.15	1.08	1.05	1.02	0.97	0.92

Actual cooling capacity calculation:

Actual cooling capacity=amendment coefficient of cooling capacity × nominal cooling capacity

——nominal cooling capacity could be found from the performance parameters list

——amendment coefficient of cooling capacity could be found from table above.

Amendment coefficient of heating capacity under different indoor/outdoor DB/WB temperature

Indoor air inlet DB temperature °C	Outdoor air inlet WB temperature °C						
	-15	-10	-5	0	6	10	15
16	0.45	0.53	0.65	0.80	1.02	1.13	-
18	0.47	0.55	0.61	0.76	1.02	1.12	-
20	0.46	0.54	0.6	0.75	1	1.11	1.25
21	0.42	0.49	0.59	0.72	0.99	1.1	1.24
22	0.41	0.49	0.58	0.71	0.97	1.09	1.23
24	0.39	0.45	0.56	0.7	0.96	1.08	1.22

Actual heating capacity calculation:

Actual heating capacity=amendment coefficient of heating capacity × nominal heating capacity

——nominal heating capacity could be found from the performance parameters list

——amendment coefficient of heating capacity could be found from table above.

Amendment coefficients of heating and cooling capacity under different height drop

Different Cooling Capacity modified coefficients at different height:

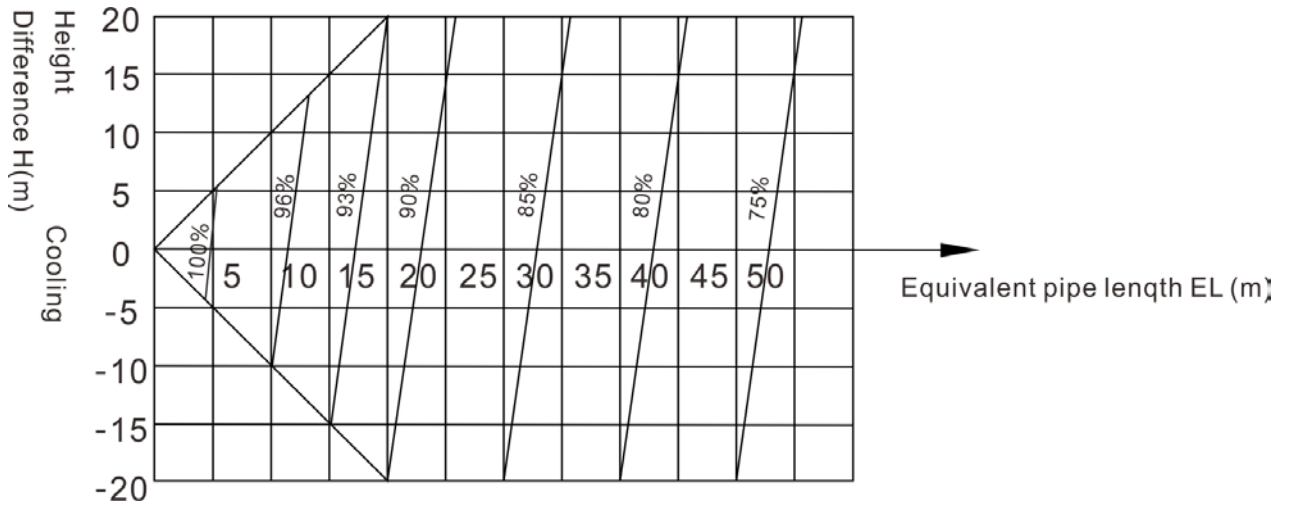

Note:

H = Height of Outdoor Unit — Height of Indoor Unit

Different Heating Capacity modified coefficients at different height:

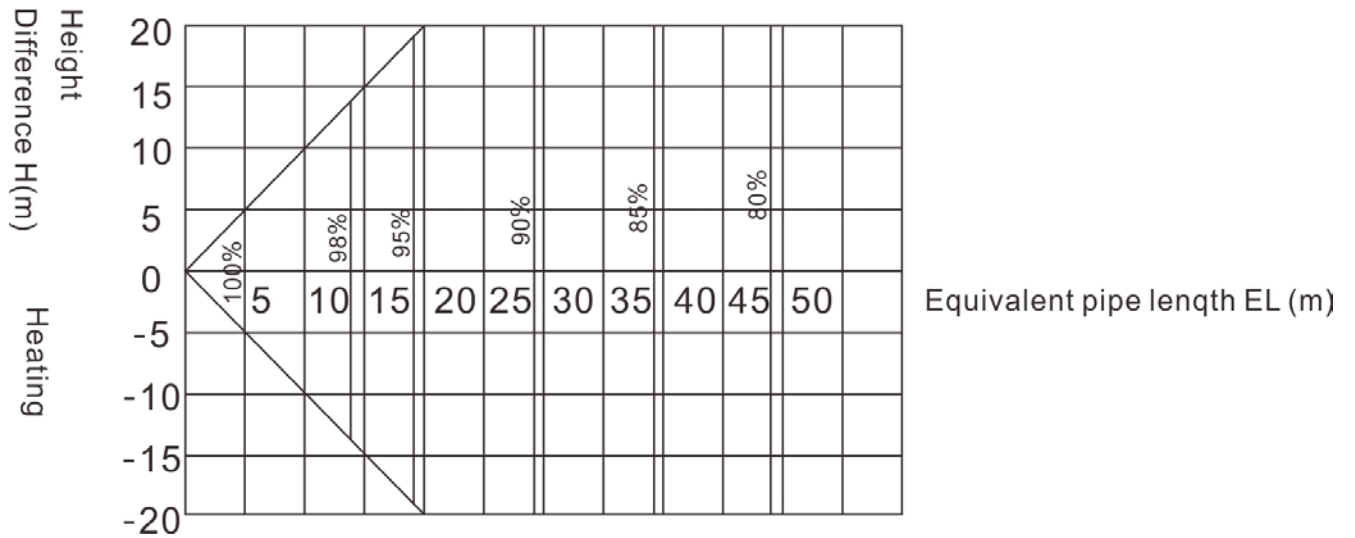

Note:

H = Height of Outdoor Unit — Height of Indoor Unit

4. Demension

ALCA-H12/4R1AA, ALCA-H18/4R1AA

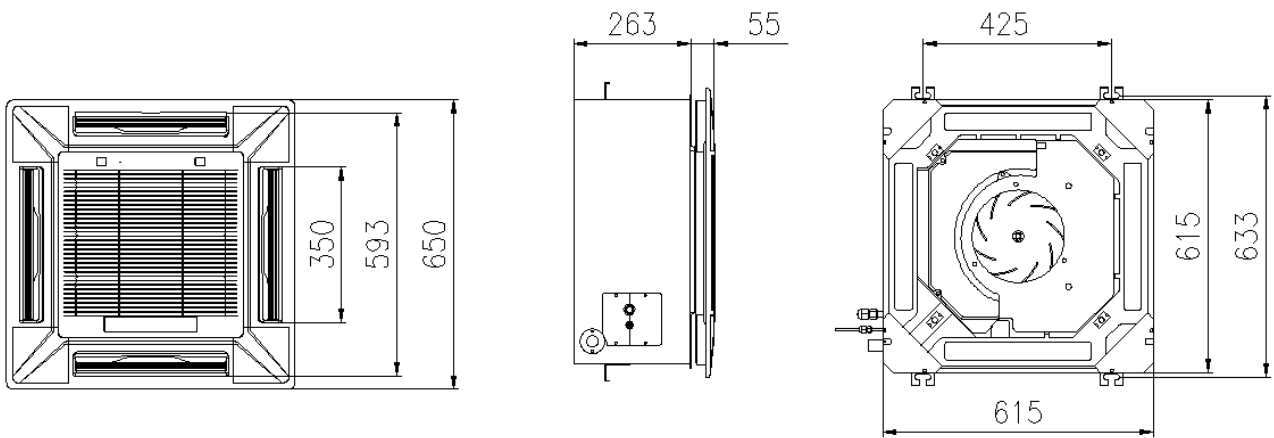

ALCA-H24/4R1AA, ALCA-H36/4R1E, ALCA-H36/5R1AA

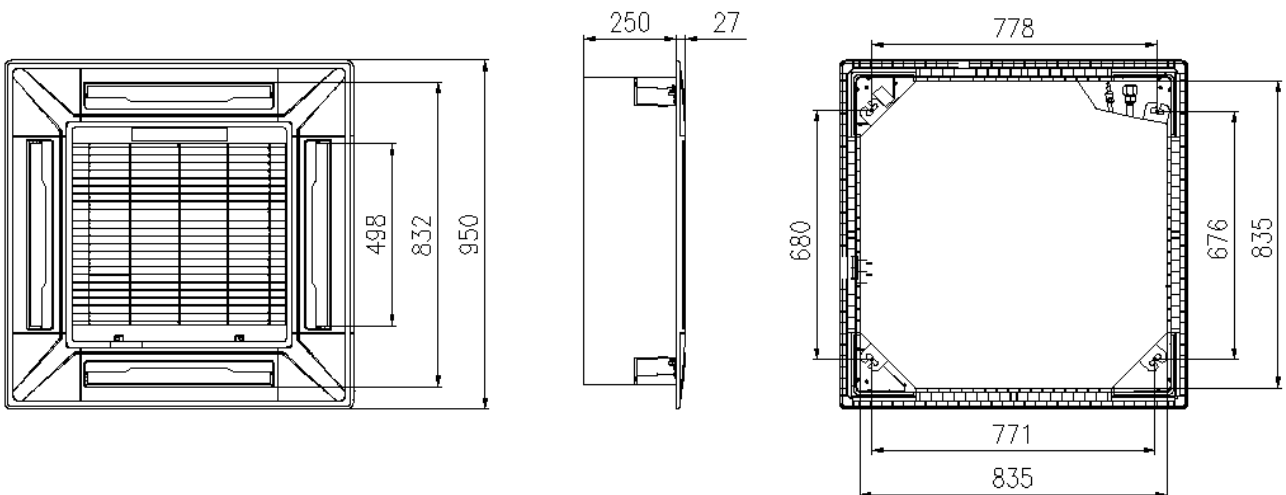

ALCA-H48/5R1AA, ALCA-H60/5R1AA

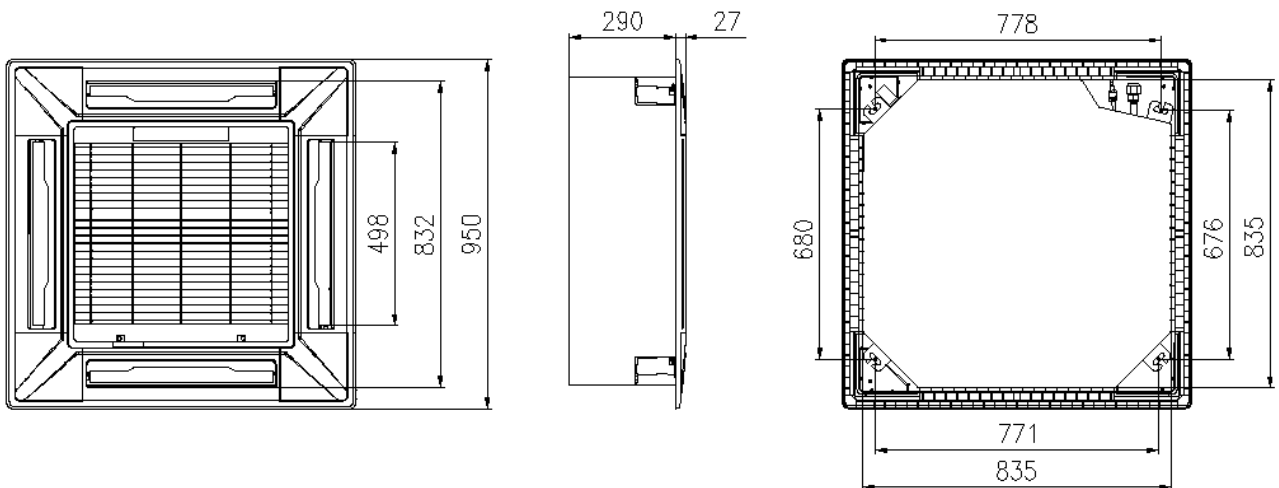

5. Electrical wiring and connection

ALCA-H12/4R1AA, ALCA-H18/4R1AA

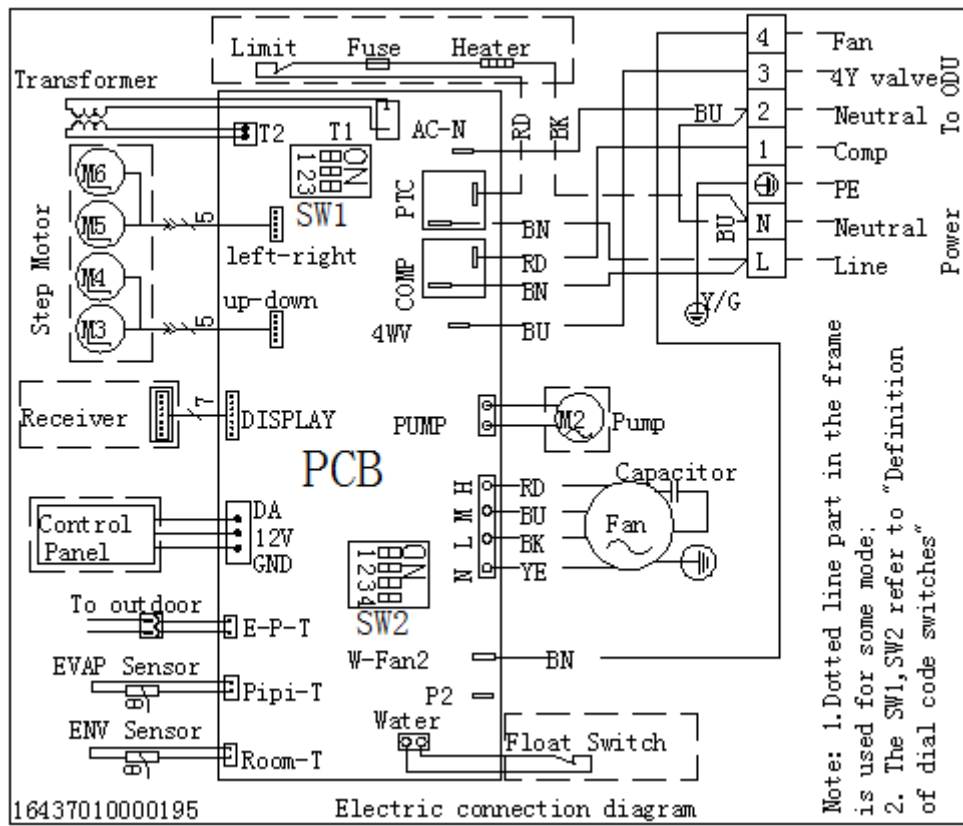

ALCA-H24/4R1AA

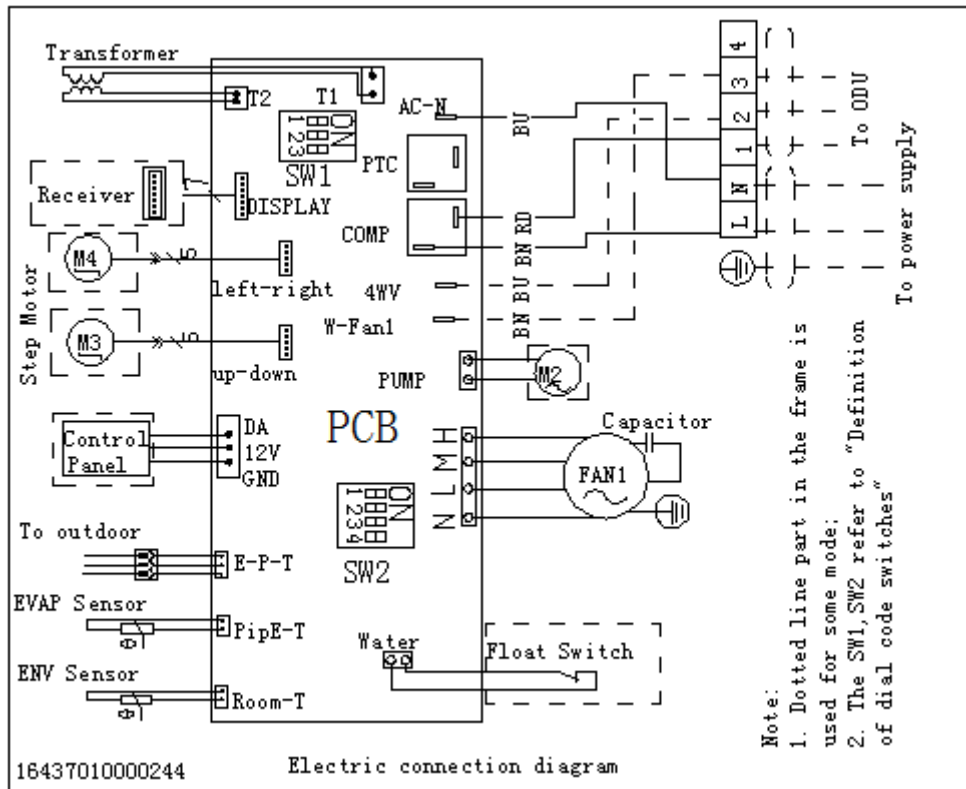

ALCA-H36/4R1E ,ALCA-H36/5R1AA ,ALCA-H48/5R1AA , ALCA-H60/5R1AA

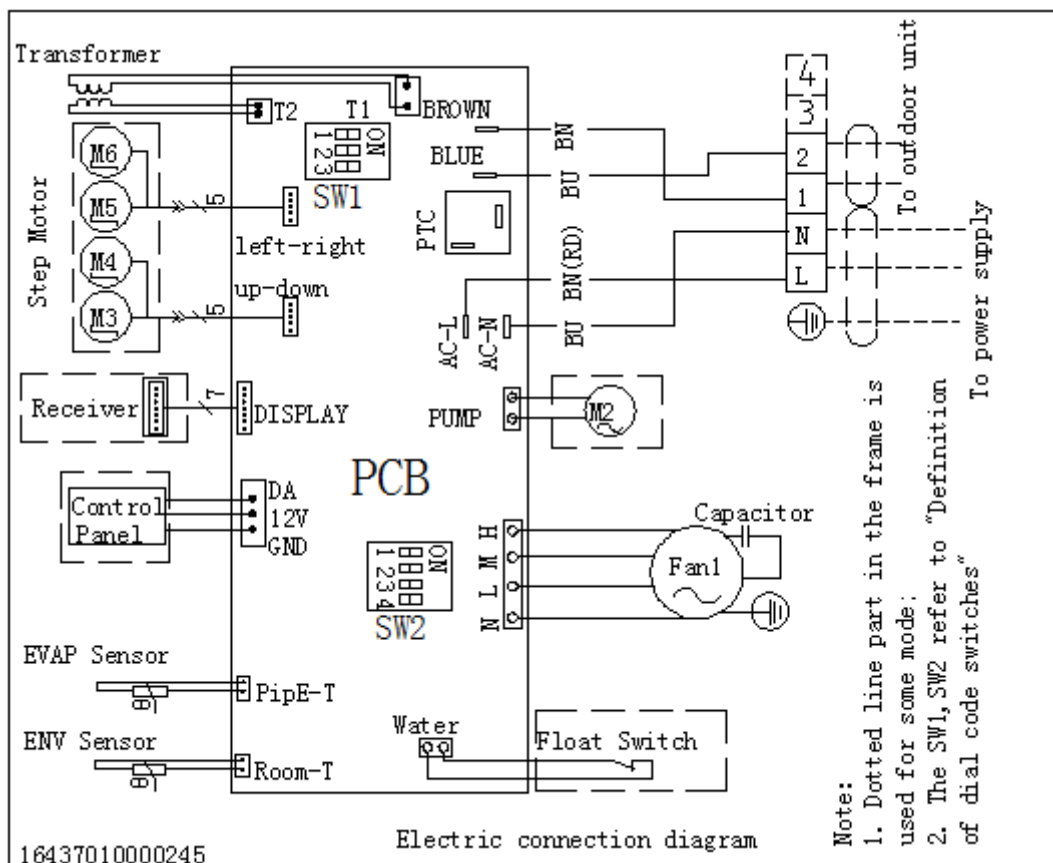

Electrical connection

ALCA-H12/4R1AA ALCA-H18/4R1AA

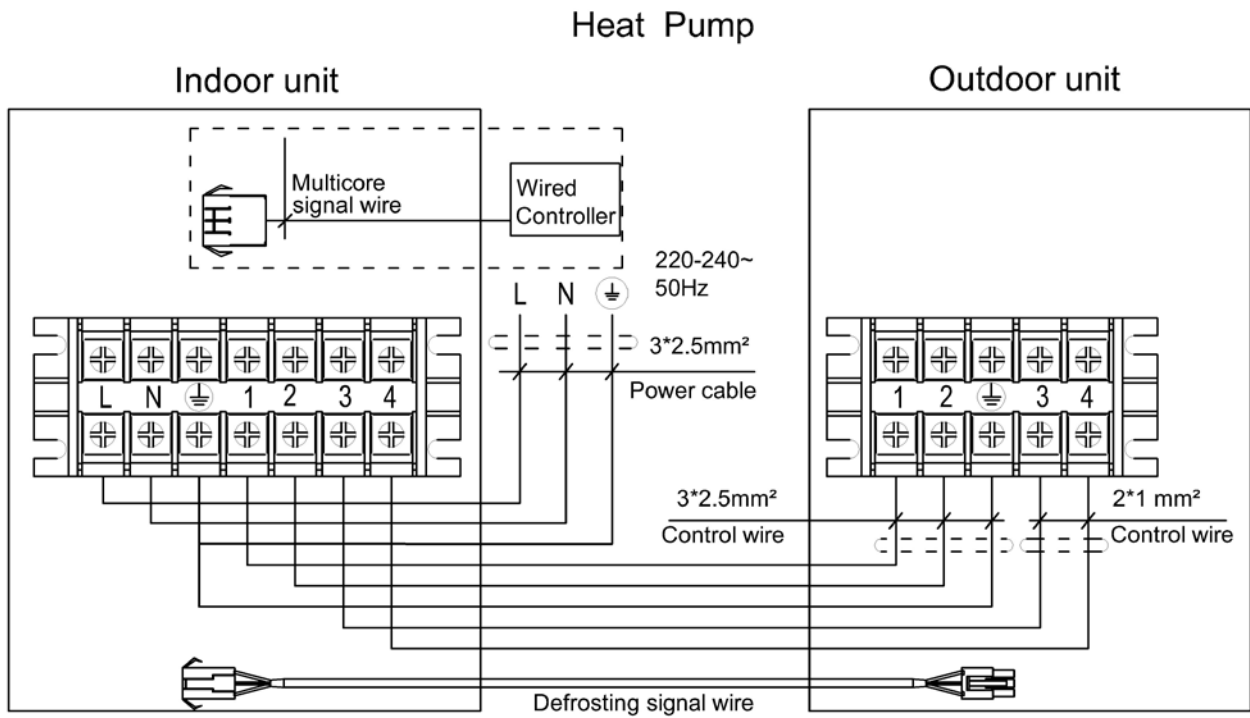

ALCA-H24/4R1AA,

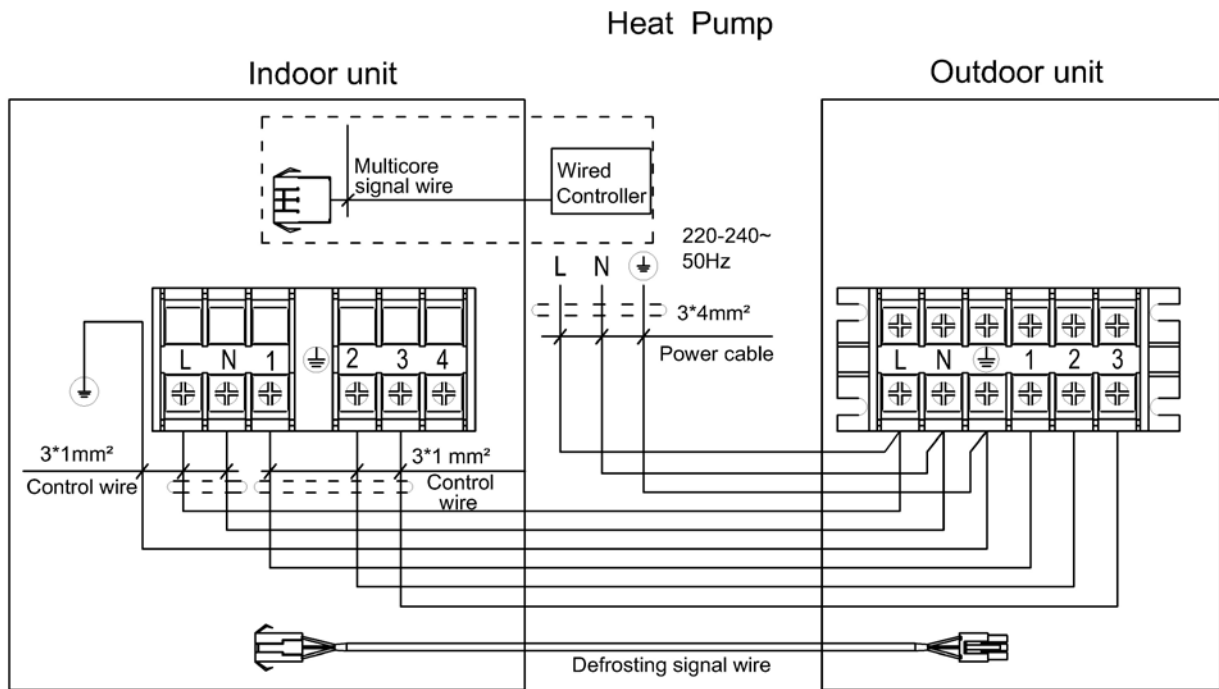

ALCA-H36/4R1E

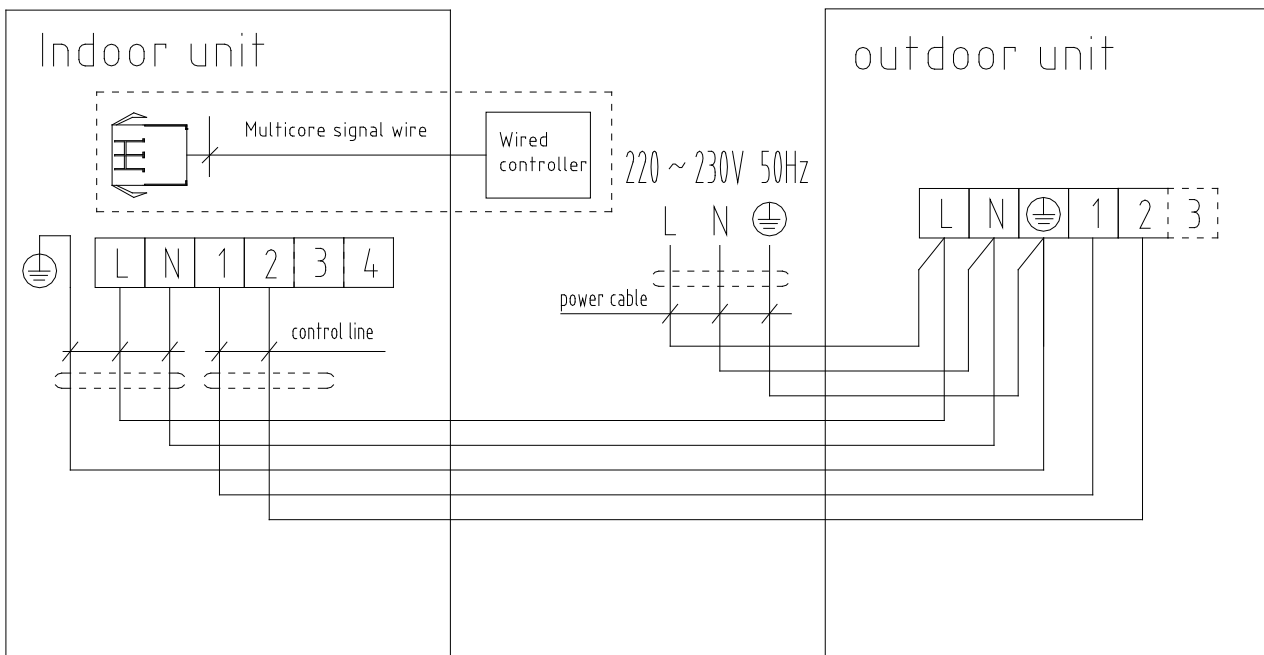

ALCA-H36/5R1AA , ALCA-H48/5R1AA , ALCA-H60/5R1AA

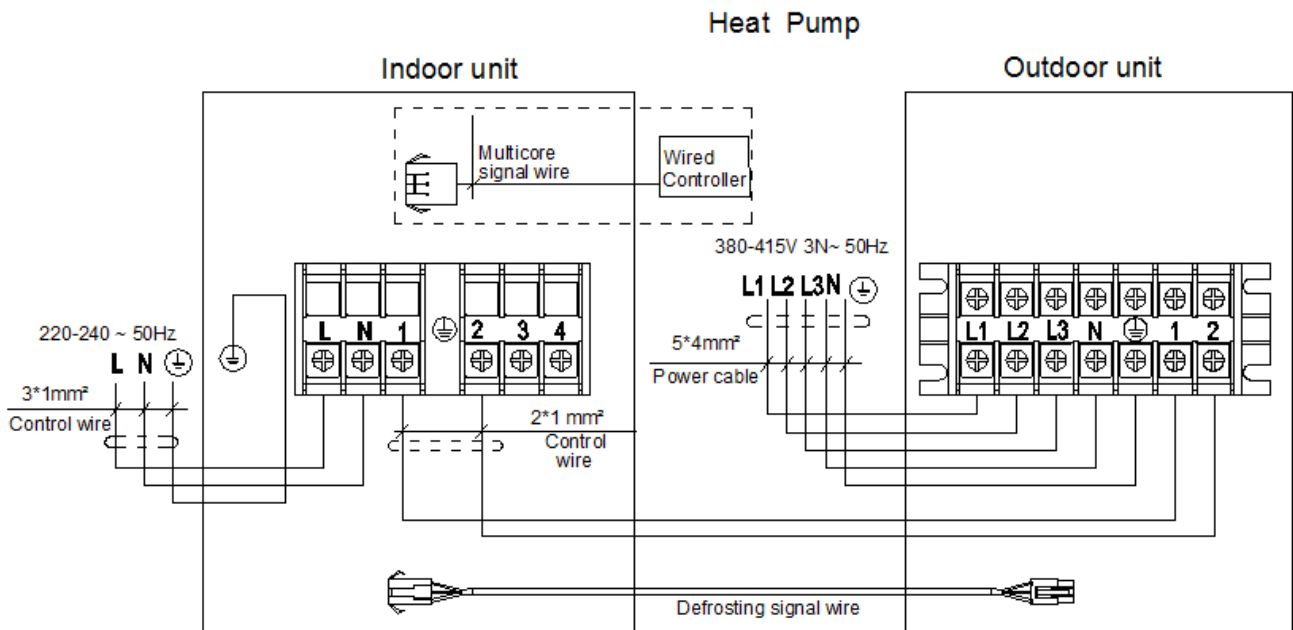

Introduction of Control Board QRDL-3F(2S)-SYE1 (indoor unit) (match with the outdoor unit which the Power supply is 220V-240V, 1PH)

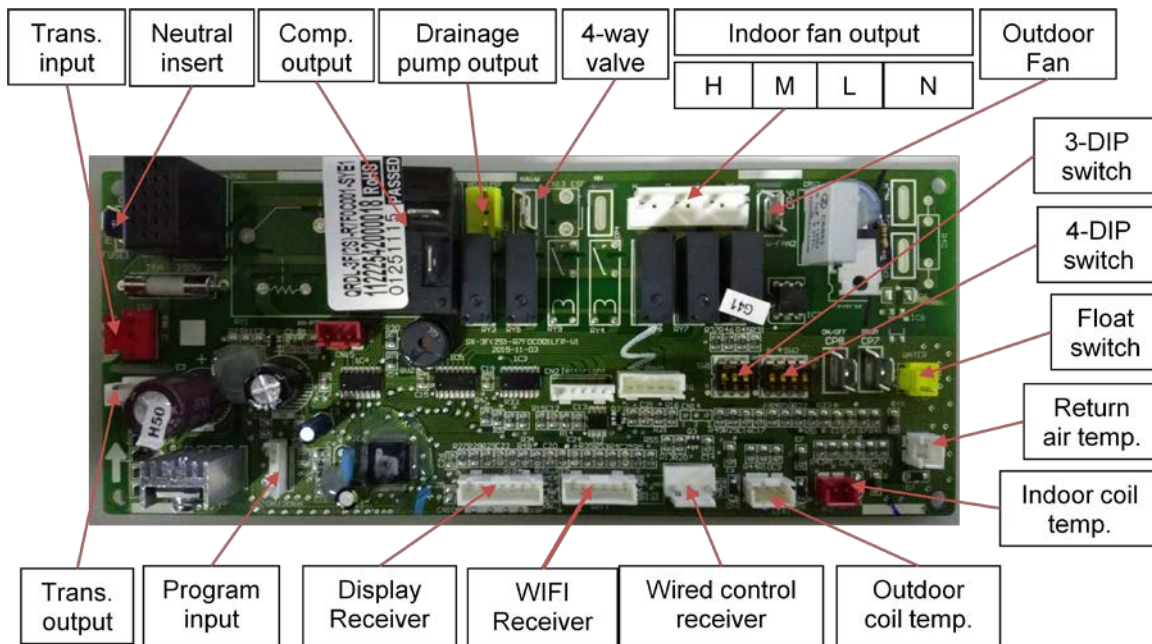

Introduction of control board QRD-SN3F(EX)-SYE1 sockets (Indoor unit) (match with the outdoor unit which the Power supply is 380V-415V, 3PH)

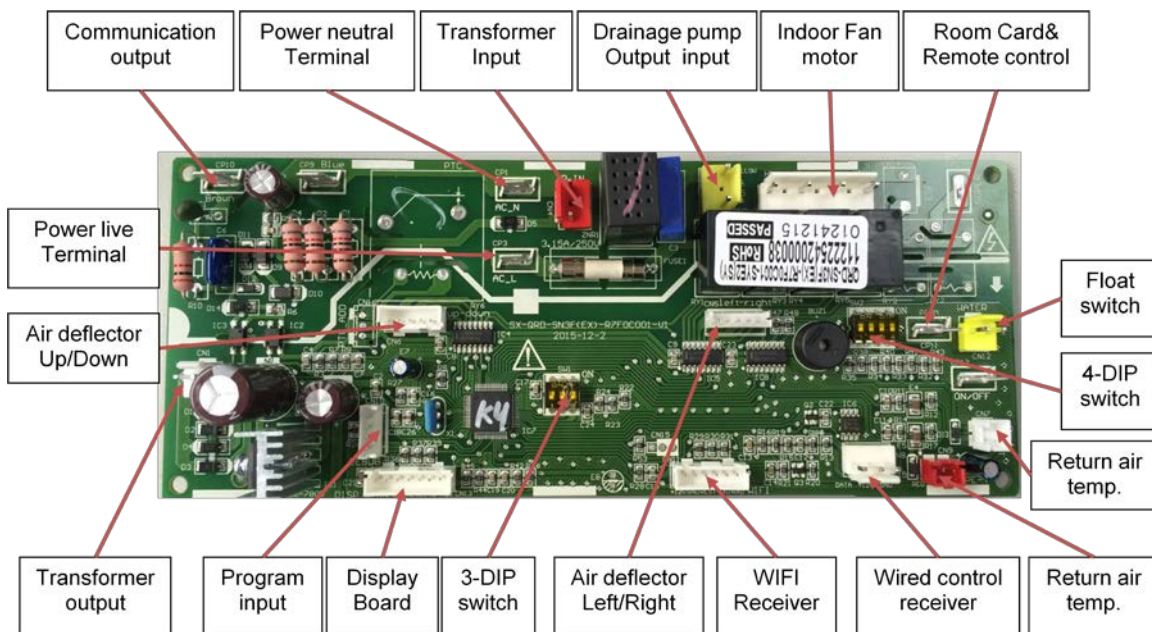

6.Installation

6.1 Preparation before installation

Please buy following spare parts from your local market before installation	Besides general implements, other implements are needed when connecting the pipe
Hung bolts M12, 4 pcs	Acetylene cylinders, oxygen cylinders (when longer pipe used it should be welded)
Drainage pipe PVC	One set pipe cut machine. (cut copper pipe)
Copper connecting pipe	Refrigerant cans, electronic balance (when longer pipe used additional gas should be charged)
Adhesive belt (big size) 5 pcs, (small size) 5 pcs	Pressure gauges, pipe clamp, welding torch, 2B silver electrode
Heat insulation material used to connect copper pipe (PE foam material, its thickness is more than 8mm)	Wrench 2 pcs, one of them is with adjustable torque wrench (42N.m,65N.m,100N.mm)
Power cable, electrical wire between indoor and outdoor unit(Must be in accordance with the wire diameter in the wiring diagram)	Nitrogen cylinder (in order to prevent oxidation when welding, using Nitrogen to replace the air)

6.2 Installation diagram

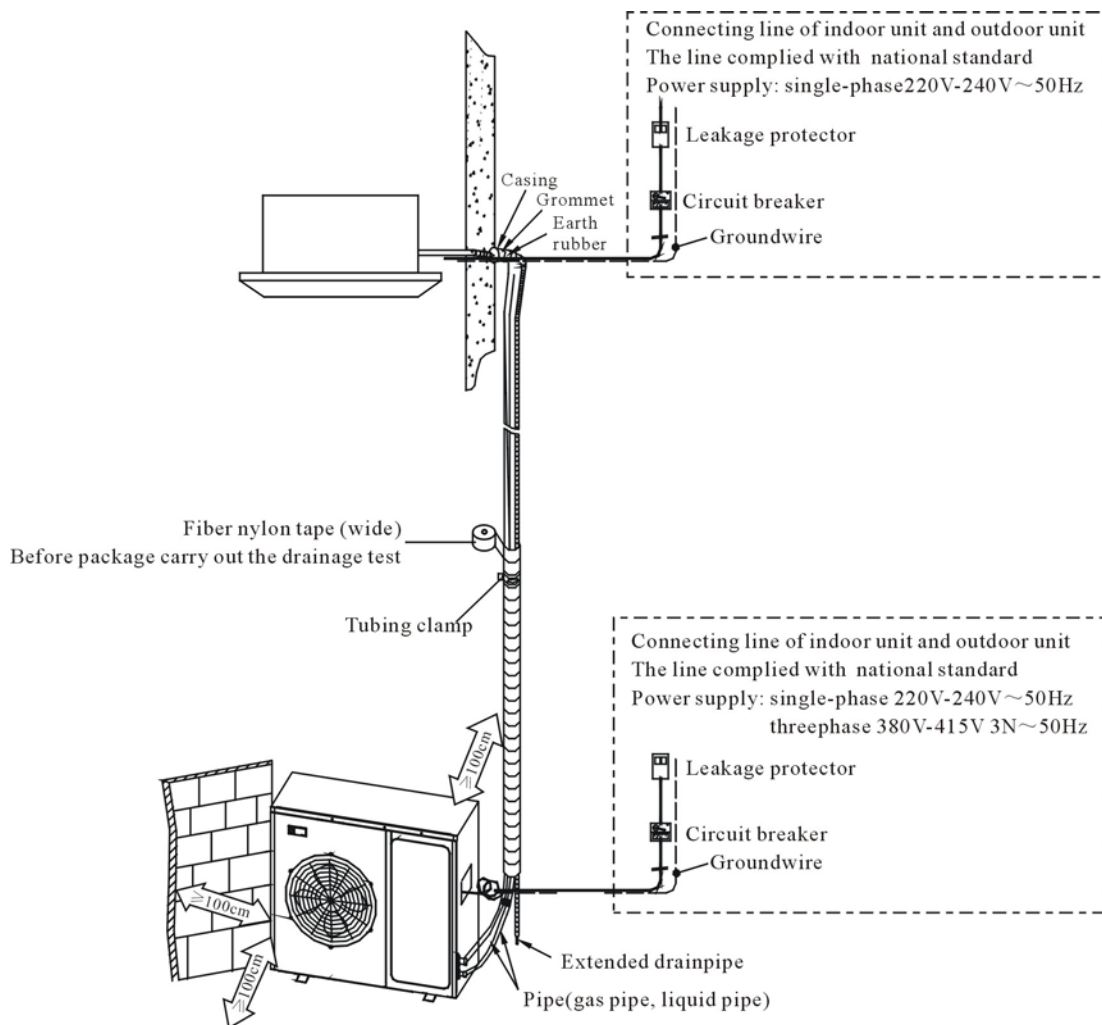

6.3 Installation precaution

- ◇ Hanging location should be able to support the unit's weight, there should be no increase in noise and vibration. If the hanging location needs reinforcement, it should be reinforced before installation;
- ◇ Choose the space above the ceiling that can put the indoor unit inside;
- ◇ The location should be easy for drainage;
- ◇ The unit should not be installed in the heat source, steam source oil mist places (such as machine room, kitchen, laundry room, mechanical workshop, etc.) in order to avoid performance degradation, electric shock, plastic parts corrosion which lead to unit broken;
- ◇ Choose the location at least 1 meter away from TV and radio, in order to avoid interference to them
- ◇ There is no obstacles getting in the way of air circulation, cold air can evenly spread to all corners of the room;
- ◇ In order to facilitate maintenance and repair, there should be certain distance between indoor unit and obstacles;
- ◇ Refrigerant R22 is used for this unit, which is non-flammable and non-toxic gas. As the proportion of refrigerant is bigger than air, so if it leaks the gas will be filled on the ground. Therefore, if the units mounted on a closed room there must be good ventilation to prevent suffocation. In case of leakage of refrigerant, units should immediately stop running, and contact with maintenance personnel in time. There must be no fire at the site, because the refrigerant will turn to harmful gas when get to the fire.

6.4 The distance between indoor unit and obstacle

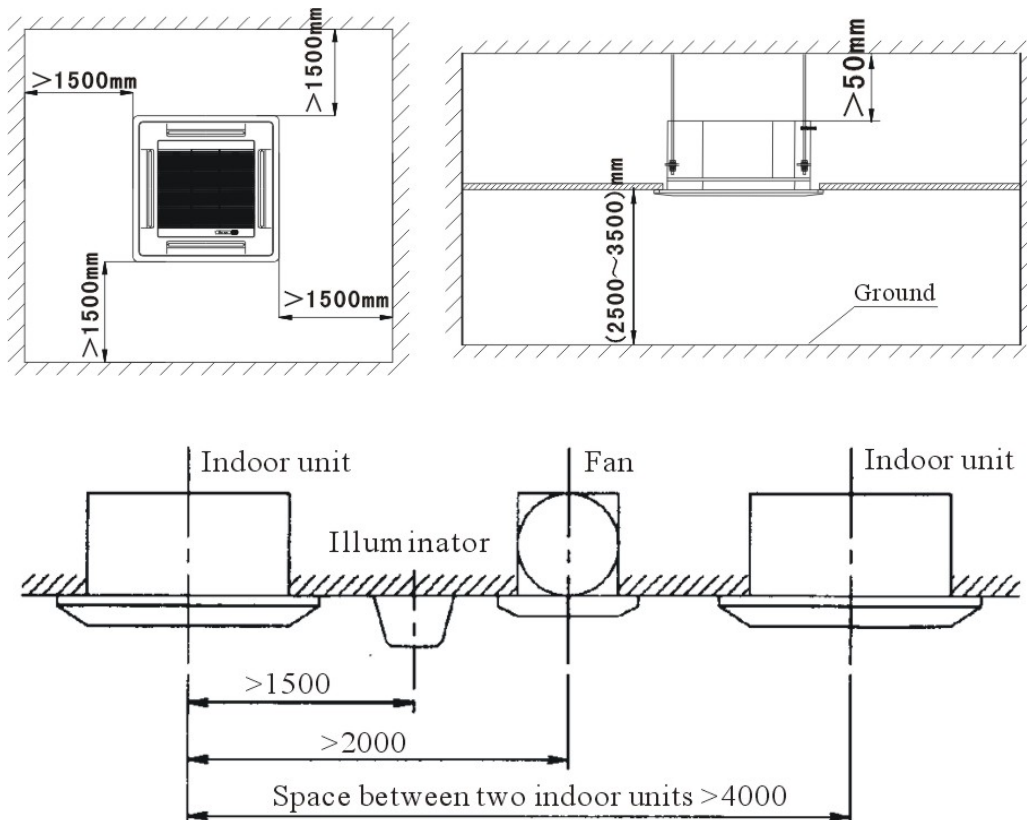

6.5 Indoor unit suspension

- ◇ Select the suspension foundation:

The suspension foundation is a structure of either wooden frame or reinforced concrete. It must be

firm and reliable to bear at least 4 times weight of itself and capable of bearing vibration for long periods.

- ◇ Fixing of suspension foundation:
- ◇ Fix the suspension bolts either as shown in the picture or by a steel or wooden bracket.

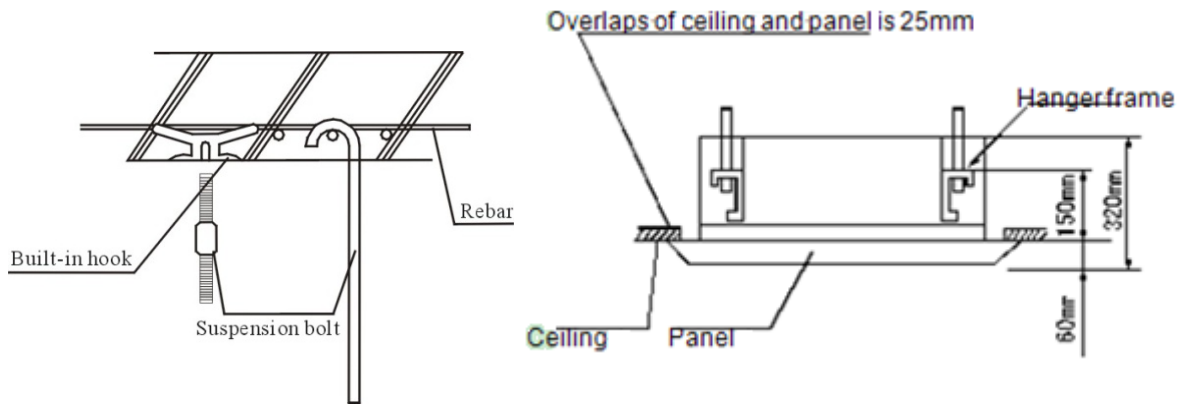

- ◇ If this unit is installed on a sloping ceiling, a cushion block should be installed between the ceiling and the air outlet panel, in order to ensure that the unit is installed on a level surface. This is as shown in the drawing as follows:

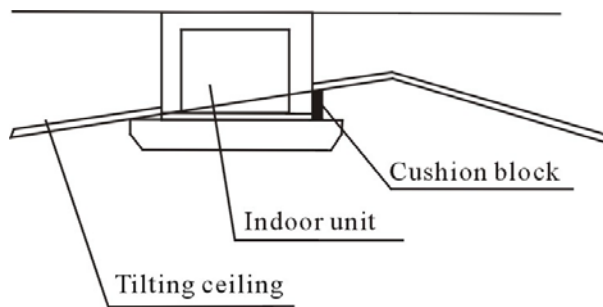

- ◇ Adjust the relative position of the suspension hook on the suspension bolt so that the unit can be in level position in all directions. Check with a level gauge after the installation is complete in order to ensure that the indoor unit is horizontal, otherwise it will cause water leakage, air leakage etc.
- ◇ Tighten the bolt and ensure that four hooks are in close contact with the nuts and washers, and the unit is suspended firmly and reliably onto the hooks.
- ◇ After the unit is installed ensure it is secure and does not shake or sway.
- ◇ Ensure that the centre of the indoor unit is in alignment with the centre of the opening in the ceiling.

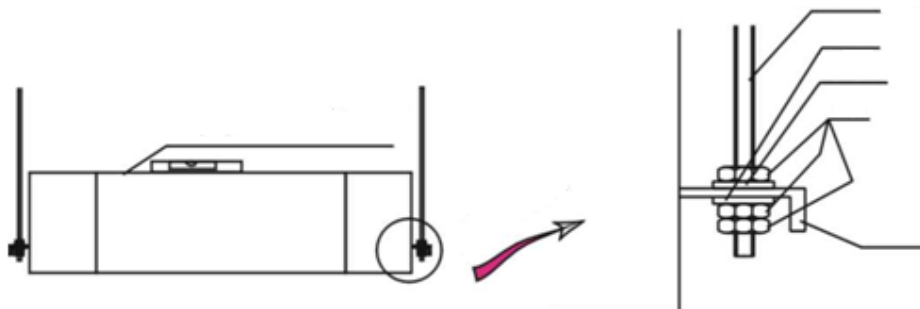

6.6 Drainage pipe installation

The drain pipe should be properly insulated to prevent the generation of condensation. Heat insulation material: the thickness of rubber insulation pipe should be more than 8mm

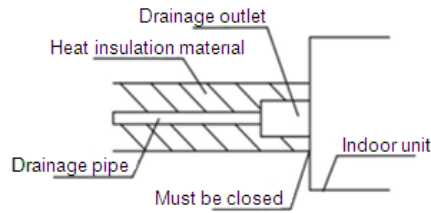

- ◇ Drainage pipe must have a downward gradient (1 / 50 1 / 100). If the drain pipe is installed ups and downs, it will cause water backflow or leakage etc.

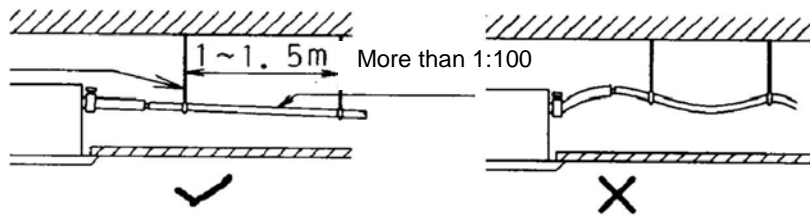

- ◇ The unit has a drain pump which will lift up to 1200mm. However after the pump stops the water still in the pipe will drain back and may overflow the drain tray causing a water leak. For this reason please install the drain pipe as shown

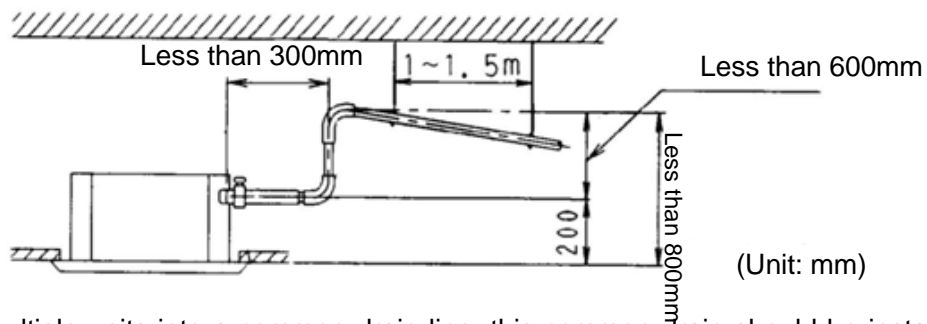

- ◇ When draining multiple units into a common drain line, this common drain should be installed about 100mm below each units drain outlet, as shown in the drawing.

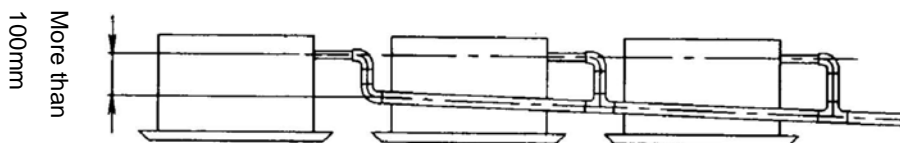

- ◇ When finish installation please carry out the drainage test to ensure that the water flow through the pipeline fluently, and carefully observe the junction to ensure that there is no water leakage. If the unit is installed in the newly built house, strongly recommend that this test taken before the ceiling installation. Even it is the heating only unit, this test is unavoidable.

6.7 Panel installation

As to the MB12 panel please refer to the following picture, the panel has four hooks which attach to corresponding hangers on the unit and the panel should be positioned using these first. The panel is then fixed into position by four bolts which are accessed through the four corner panels on the grille.

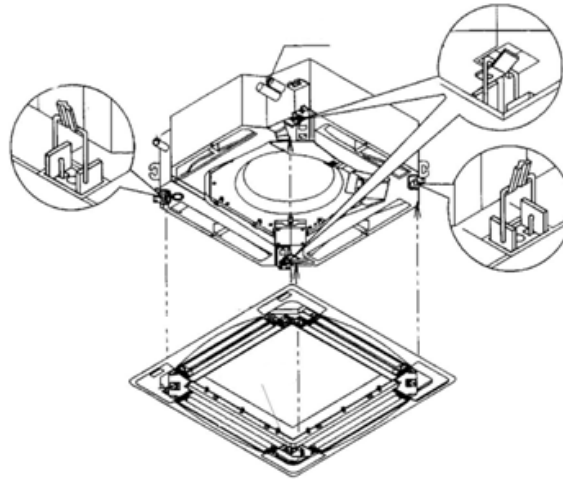

Notes:

When installing please ensure that the position of swing motor is in accordance with the position of the pipes of the unit.

6.8 Connect duct, fresh air ventilation

In order to meet different customers' requirements and their different usage environment, 3hp and 5hp indoor unit reserves one fresh air ventilation hole and four duct connection holes. The fresh air can be introduced from outside or through duct.

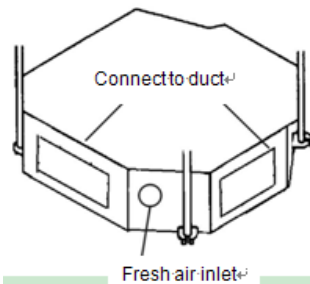

- ◇ Fresh air ventilation: In the corner of the unit there is a circular fresh air connection hole, if users want this feature, please cut down the circular metal sheet and connect it to the duct. Fresh air replacement hole is connected to the return air inlet of the indoor unit, when in the process of operation due to the negative pressure, the fresh air can be introduced from outside.
- ◇ Connect to duct: There are four rectangular connection holes on the four sides of the unit. If users want to connect it to the duct, please close the outlet to the side which needs connecting to the duct as well as cut down the rectangular metal sheet.

Notes:

1. Only under special usage that it is allowed to connect to duct pipe and the length of the duct pipe should be less than 5 meters.
2. Using the duct that can prevent frost and noise.
3. Using heat insulation material to seal the junction between duct and the unit.

7.Explode view

ALCA-H12/4R1AA, ALCA-H18/4R1AA

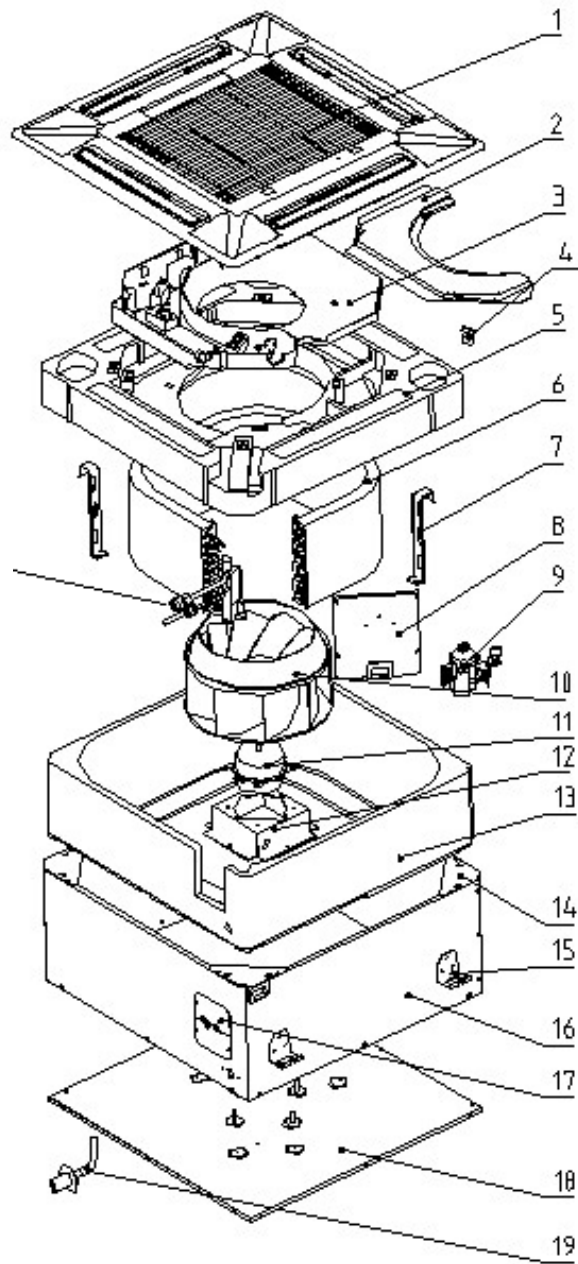

ALCA-H12/4R1AA, ALCA-H18/4R1AA

N0.	Chinese name	Part Name	Quantity
1	面板 MB13(英文)	Panel MB13	1
1.1	回风格栅组件	Return-air grille assembly	1
1.2	空气过滤网	Air filter net	1
1.3	导风叶片	guide wind vane	4
1.4	步进电机	Step motor	4
1.5	显示灯板	Display board	1
1.6	面板围框组件	Panel frame assembly	1
2	电控盒盖	Cover for electric components	1

3	电控盒总成	Electric assembly	1
3.1	电容	capacitance	1
3.2	控制板	PCB board	1
3.3	变压器	Transformer	1
3.4	端子板 7 位	Terminal board	1
3.5	传感器 0.5m	Sensor 0.5m	1
3.6	传感器 0.9m	Sensor 0.9m	1
4	橡胶塞	Rubber plug	1
5	接水盘组件	Water pan	1
6	蒸发器总成	Evaporator assembly	1
6.1	蒸发器组件	Evaporator part	1
6.2	蒸发器出气管组件	Evaporator outlet tube assembly	1
6.3	蒸发器进液管组件	Evaporator inlet tube assembly	1
7	蒸发器挂钩	Evaporator Pothook	2
8	蒸发器连接板	Evaporator connect board	1
9	排水泵	Drain pump	1
9.1	浮子开关	Bodder switch	1
10	风轮	Wind wheel	1
11	电机	Fan motor	1
12	电机支架	motor holder	1
13	风道	Air passage	1
14	接水盘固定板	Water pan holder	4
15	挂钩	Pothook	4
16	围板 A	Boarding A	1
16.1	围板 B	Boarding B	1
17	阀板 A	Valve board A	1
17.1	阀板 B	Valve board B	1
18	底盘组件	Chassis	1
19	塑料排水接管	Plastic drainage Hose	1
19.1	塑料排水软管	Plastic drainage pipe	1

ALCA-H24/4R1AA, ALCA-H36/4R1E ,ALCA-H36A5/R1AA, ALCA-H48A5/R1AA , ALCA-H60A5/R1AA

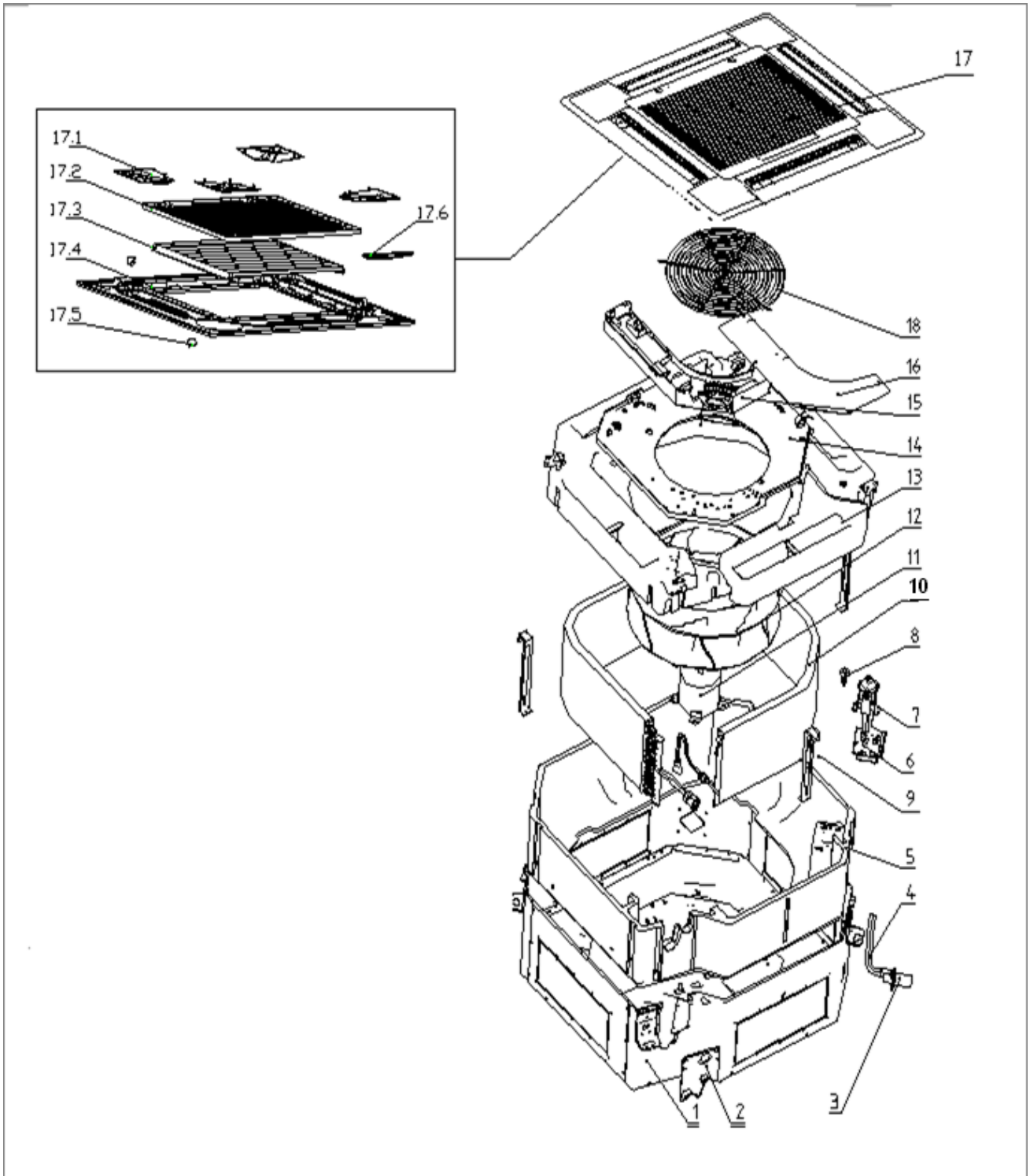

ALCA-H24/4R1AA, ALCA-H36/4R1E ,ALCA-H36/5R1AA, ALCA-H48/5R1AA, ALCA-H60/5R1AA

No.	Chinese Name	Part Name	Quantity
1	钣金套件	Sheet metal Assembly	1
1.1	围板 A	Cabinet A	2
1.2	围板 B	Cabinet B	1
1.3	围板 C	Cabinet C	1
1.4	底盘组件	Chassis assembly	1
1.5	挂钩	hook	4
1.6	压线扣	Wire fastener	5
1.7	电机线固定板	Power line fixed plate	1
2	阀板	Valve plate	1
3	塑料排水软管	Drain pipe	1
4	塑料排水软管	Drain flexible pipe (Drain pump)	1
5	底盘泡沫组件	Chassis foam assembly	1
6	水泵支架	Drain pump support	1
7	排水泵	Drain pump	1
8	浮子开关	Float switch	1
9	蒸发器挂钩(喷涂)	Evaporator hook	3
10	蒸发器总成	Evaporator assembly	1
10.1	蒸发器组件	Evaporator assembly	1
10.2	蒸发器进液管组件	Evaporator inlet tube assembly	1
10.3	蒸发器出气管组件	Evaporator outlet tube assembly	1
11	电机	Fan motor	1
12	风轮	Fan	1
13	接水盘组件	Drain pan assembly	1
14	导风圈	Guide wind loop assembly	1
15	电控盒总成	Electric box assembly	1
15.1	电控盒	Electric box	1
15.2	控制板	PCB board	1
15.3	变压器	Transformer	1
15.4	风机电容	Capacitor	1
15.5	端子板	Terminal Block	1
16	电控盒盖	Electric control box cover	1
17	面板	Panel Assembly	1
17.1	边角盖板	Corner Cover	1
17.2	过滤网	Air Filter	1
17.3	围框	Cabinet	1
17.4	回风格栅	Air Inlet Grilling	1
17.5	步进电机	Step motor	1
18	风叶网罩	Mesh	1

Ceiling & floor type

1.Feature.....	34
2.Specfication	36
3.Capacity amendment	39
4.Demension	41
5.Electrical wiring and connection.....	41
6.Installation.....	47
7.Explode view	49

1.Feature

Ceiling& Floor type A/C (Cooling-only or Heat pump) can be installed under the ceiling and also on the floor. Compared with normal Floor &Standing type A/C, it can be hoisted under the ceiling,saving room space, it is also the updating Product for Floor & Standing type A/C.

Application occasions:

Small super market, restaurant, office, meeting room, villa living room, family bedroom, and it can even be used as the updating Product for modern residential A/C.

Features:

- ◇ Suspended ceiling, installation under ceiling, saving room space, it is very suitable for family or office place;
- ◇ Convenient and flexible for indoor unit installation, can be installed under the ceiling or on the floor;
- ◇ With Setting or Auto two operation modes, multi fan speed, makes you feel more comfortable;
- ◇ Shell was formed by mold, and the appearance is “slim”, “elegant”, “fashion” and “comfortable”;
- ◇ Special insulation design, achieves high heat insulation efficiency and no condensation on shell;
- ◇ Long term air filter, the wash period is two times longer than normal filter, maintenance is free;
- ◇ Adopting low noise centrifugal fan, strong wind but quiet operation, the silence design achieves harmony residential living;
- ◇ All the installation and maintenance can be done in the bottom of unit, saving the maintenance space;
- ◇ 3-phase power supply type units with low ambient temperature cooling function, which makes the unit can run normally on the condition that the ambient temperature falls down to -15°C;;
- ◇ Standard remote controller and optional wired controller;
- ◇ Auxiliary electric heater for heat pump unit, with fast heating and low ambient temperature heating functions;
- ◇ Failure automatic detection, if there is a failure, the indicator will flash and the failure code will display on the wired controller, the failure cause is easier to be found..
- ◇ Filter to dismantle to wash convenience, don't need to make use of any tool, can move to dismantle to filter a net to clean.
- ◇ Ultra slim design, the thickness only 205 mm, and have vertical and horizontal swing function.

Function introduction

Type	Item	ALCF-H**R1C						
		12/4	18/4	24/4	36/4	36/5	48/5	60/5
Protection	High pressure protection	-	-	-	—	●	●	●
	Low pressure protection	-	-	-	—	●	●	●
	Compressor overloading protection	●	●	●	●	●	●	●
	High Ext. temperate protection	-	-	-	—	●	●	●
	Phase protection(Phase-loss, phase- reverse)	-	-	-	—	●	●	●
	Over-heating protection	●	●	●	●	●	●	●
	Anti-freezing protection	●	●	●	●	●	●	●
	Sensor failure alarm	●	●	●	●	●	●	●
	Failure code display	●	●	●	●	●	●	●
Comfort	Cooling	●	●	●	●	●	●	●
	Heating	●	●	●	●	●	●	●
	3-Speed	●	●	●	●	●	●	●
	Adjustable ESP	-	-	-	—	-	-	-
	Auto-restart(Optional)	●	●	●	●	●	●	●
	Anti-cold wind	●	●	●	●	●	●	●
	Afterheat wind blowing	●	●	●	●	●	●	●
	Timing ON/OFF	●	●	●	●	●	●	●
Operation	Time display	●	●	●	●	●	●	●
	Operation mode display	●	●	●	●	●	●	●
	Fan speed display	●	●	●	●	●	●	●
	Defrost display	●	●	●	●	●	●	●
	Timing ON/OFF display	●	●	●	●	●	●	●
	Wind angle display	●	●	●	●	●	●	●
	Sleeping mode display	●	●	●	●	●	●	●
Running	Auto start	●	●	●	●	●	●	●
	Dehumidifying	●	●	●	●	●	●	●
	Auto defrost	●	●	●	●	●	●	●
	Ventilation function	●	●	●	●	●	●	●
	Low ambient temperature cooling	●	●	●	●	●	●	●
Health	Washable air filter	●	●	●	●	●	●	●
	Fresh air interface	-	-	-	—	-	-	-
Installation	Left/right drainage	-	-	-	—	-	-	-
	Left/right pipe connection	-	-	-	—	-	-	-
	Down/back air suction	-	-	-	—	-	-	-
	Installation indicating board	-	-	-	—	-	-	-

Remarks: ● Stands for “YES”

- Stands for “NO”

2.Specification

Model	Indoor		ALCF-H18/4R1C	ALCF-H24/4R1C	ALCF-H36/4R1
	Outdoor		AL-H18/4R1D(U)	AL-H24/4R1D(U)	AL-H36/4R1(U)
Factory Model	Indoor		ALCe-H18A4/R1C5 -B7	ALCe-H24B4/R1C5 -B7	ALCe-H36A4/R1- C5
	Outdoor		AL-H18A4/R1(T)-B7	AL-H24A4/R1(T)-B7	AL-H36A4/R1(T)
Factory Model	Indoor		16109022000011	16109022000007	16209005000008
	Outdoor		16107022000019	16107022000018	16107022000001
Power Supply		V~,Hz, Ph	220~240,50,1	220~240,50,1	220~240,50,1
Capacity	Cooling	Btu/h	18000	24000	36000
		kW	5.3	7.2	10.6
	Heating	Btu/h	20000	27500	37500
		kW	5.8	8.08	10.9
Electric Data	Rated Cooling Power Input	kW	1.72	2.35	3.52
	Rated Heating Power Input	kW	1.77	2.40	3.45
	Rated Cooling Current	A	7.9	10.09	17
	Rated Heating Current	A	8.13	11.59	16.5
Performance	EER	W/W	3.08	3.06	2.81
	COP	W/W	3.28	3.37	3.34
Indoor Fan Fotor	Model		YSK-40W-4	YSK-70W-4	YSK-70W-4
	Brand		Weiling	Weiling	HUATE
	Output Power x Fan quantity	W	40x1	70x1	70
	Capacitor	uF	2.5	4	4
	Speed (Hi/Mi/Lo)	r/min	1250/1100/900	1386/1108/970	1386/ 1108/ 970
Indoor Coil	Number Of Row		3	3	3
	Tube Pitch(a)x Row Pitch(b)	mm	20.5x12.7	20.5x12.7	20.5x12.7
	Fin Spacing	mm	1.6	1.6	1.6
	Fin Material		Hydrophilic aluminum fin	Hydrophilic aluminum fin	louver
	Tube Outside Dia.and Material	mm	φ7,Inner grooved	φ7,Inner grooved	φ7 , Inner grooved
	Coil Length x Height x Width	mm	599x246x38.1	950x246x38.1	950x242x38.1
	Heat Exchanging Area	m ²	6.30	10.00	8.89
Indoor Unit	Indoor Air Flow (Hi/Mi/Lo)	m ³ /h	850/680/595	1200/960/840	1500/1200/1050
	Noise Level(Hi/Mi/Lo)	dB(A)	43/40/34	46/43/38	50/47/41
	Net Dimension (W*H*D)	mm	929x660x205	1280x660x205	1280x660x205

	Packing Dimension (W*H*D)	mm	1010x720x290	1360x720x290	1360x720x290
	Net Weight	Kg	25	32	33
	Gross Weight	Kg	28	37	40
Refrigerant Pipe	Liquid Side	mm	6.35	9.52	9.52
	Gas Side	mm	12.7	15.88	15.88
	Max. Refrigerant Pipe Length	m	20	30	20
	Max. Difference In Level	m	15	15	15
Operation Temperature Range		°C	16~32	16~32	16~32
Ambient Temperature Range(Cooling/Heating)		°C	-15~49/-15~24	-15~49/-15~24	-5~49
Application Area		m ²	21-35	28-47	42-70
Connection Wiring	Power Wiring(Indoor)	mm ²	3x2.5mm ²	/	3x4mm ²
	Power Wiring(Outdoor)	mm ²	/	3x6mm ²	5x4mm ²
	Signal Wiring	mm ²	3x2.5mm ² +2x1mm ²	3x2.5mm ² +3x1mm ²	2x1mm ²
Wireless Remote Controller			YKR-K/001E	YKR-K/001E	YKR-K/001E
Qty'per 20'& 40'&40HQ(Only For Reference)		Set	60/134/149	43/92/104	36/82/88

Note:

1. Working condition of the cooling capacity measured: Inside the room DB temperature 27°C,WB temperature19°C;Outside of the room DB temperature 35°C,WB temperature 24°C;Working condition of the heating capacity measured:Inside the room DB temperature 20°C,Outside of the room DB temperature 7°C,WB temperature 6°C。
2. Parameters above are all measured when the connecting pipe is 5 meters.
3. Parameters above may be modified as product improvement. We keep the right to change the product specifications without prior notice, please take the parameters listed on the nameplate as criterion.

Model	Indoor		ALCF-H36/5R1C	ALCF-H48/5R1C	ALCF-H60/5R1C
	Outdoor		AL-H36/5R1D(U)	AL-H48/5R1D(U)	AL-H60/5R1D(U)
Factory Model	Indoor		ALCe-H36A5/R1C5-B7	ALCe-H48A5/R1C5-B7	ALCe-H60A5/R1C5-B7
	Outdoor		AL-H36A5/R1(T)-B7	AL-H48A5/R1(T)-B7	AL-H60A5/R1(T)-B7
Factory Model	Indoor		16109022000008	16109022000009	16109022000010
	Outdoor		16107022000020	16107022000022	16107022000023
Power Supply		V~,Hz,Ph	380~415,50,3	380~415,50,3	380~415,50,3
Capacity	Cooling	Btu/h	36000	48000	60000
		kW	10.6	14.0	17.6
	Heating	Btu/h	40000	53000	63500
		kW	11.7	15.5	18.5
Electric Data	Rated Cooling Power Input	kW	3.77	4.87	5.71
	Rated Heating Power	kW	3.50	5.13	5.97

	Input				
	Rated Cooling Current	A	6.76	8.88	10.42
	Rated Heating Current	A	6.28	9.33	10.83
Performance	EER	W/W	2.81	2.87	3.08
	COP	W/W	3.34	3.02	3.10
Indoor Fan Fotor	Model		YSK-70W-4	YSK-105W-4	YSK-105W-4
	Brand		Weiling	Weiling	Weiling
	Output Power x Fan quantity	W	70x1	105	105
	Capacitor	uF	4	5	4
	Speed (Hi/Mi/Lo)	r/min	1386/1108/970	1387/1108/970	1387/1108/970
Indoor Coil	Number Of Row		3	3	3
	Tube Pitch(a)x Row Pitch(b)	mm	22x19.05	20.5x12.7	22x19.05
	Fin Spacing	mm	1.6	1.6	1.6
	Fin Material		Hydrophilic aluminum fin	Hydrophilic aluminum fin	Hydrophilic aluminum fin
	Tube Outside Dia.and Material	mm	φ7.94,Innergrooved	φ7,Inner grooved	φ7.94,Inner grooved
	Coil Length x Height x Width	mm	950x242x57.15	1300x246x38.1	1300x242x57.15
	Heat Exchanging Area	m ²	15.02	13.69	20.55
Indoor Unit	Indoor Air Flow (Hi/Mi/Lo)	m ³ /h	1500/1200/1050	1800/1440/1260	1800/1440/1260
	Noise Level(Hi/Mi/Lo)	dB(A)	50/47/41	51/48/42	51/48/42
	Net Dimension (W*H*D)	mm	1280x660x205	1631x660x205	1631x660x205
	Packing Dimension (W*H*D)	mm	1360x720x290	1710x720x290	1710x720x290
	Net Weight	Kg	33	44	44
	Gross Weight	Kg	40	52	52
Refrigerant Pipe	Liquid Side	mm	9.52	9.52	9.52
	Gas Side	mm	15.88	19.05	19.05
	Max. Refrigerant Pipe Length	m	50	50	50
	Max. Difference In Level	m	30	30	30
Operation Temperature Range		°C	16~32	16~32	16~32
Ambient Temperature Range(Cooling/Heating)		°C	-15~49/-15~24	-15~49/-15~24	-15~49/-15~24
Application Area		m ²	42-70	56-93	64-107
Connection Wiring	Power Wiring(Indoor)	mm ²	3x1 mm ²	3x1 mm ²	3x1 mm ²
	Power Wiring(Outdoor)	mm ²	5x4 mm ²	5x4 mm ²	5x4 mm ²
	Signal Wiring	mm ²	2x1mm ²	2x1mm ²	2x1mm ²

Wireless Remote Controller		YKR-K/001E	YKR-K/001E	YKR-K/001E
Qty'per 20' & 40' & 40HQ(Only For Reference)	Set	36/82/88	22/55/55	22/55/55

Note:

1. Working condition of the cooling capacity measured: Inside the room DB temperature 27°C, WB temperature 19°C; Outside of the room DB temperature 35°C, WB temperature 24°C; Working condition of the heating capacity measured: Inside the room DB temperature 20°C, Outside of the room DB temperature 7°C, WB temperature 6°C.
2. Parameters above are all measured when the connecting pipe is 5 meters.
3. Parameters above may be modified as product improvement. We keep the right to change the product specifications without prior notice, please take the parameters listed on the nameplate as criterion.

3.Capacity amendment

3.1 Running range

Cooling capacity (Btu/h)		12000	18000	24000	36000	48000	60000
Power supply		220-240V~/50Hz					
Voltage		187~242V					
Ambient temperature	Cooling	-15~49°C					
	Heating	-15~24°C					

1.2 Amendment coefficient of heating & cooling capacity under different indoor/outdoor DB/WB temperature

Amendment coefficient of cooling capacity under different indoor/outdoor DB/WB temperature

Indoor air inlet temperature °C		Outdoor air inlet DB temperature °C							
DB	WB	25	30	35	40	43	45	47	49
23	16	0.98	0.94	0.89	0.85	0.82	0.79	0.74	0.71
25	18	1.05	1	0.95	0.90	0.87	0.82	0.77	0.72
27	19	1.1	1.05	1	0.95	0.91	0.87	0.84	0.79
28	20	1.12	1.07	1.02	0.96	0.93	0.90	0.86	0.81
30	22	1.19	1.13	1.08	1.02	0.99	0.96	0.91	0.88
32	24	1.26	1.20	1.15	1.08	1.05	1.02	0.97	0.92

Actual cooling capacity calculation:

Actual cooling capacity=amendment coefficient of cooling capacity × nominal cooling capacity

——nominal cooling capacity could be found from the performance parameters list

——amendment coefficient of cooling capacity could be found from table above.

Amendment coefficient of heating capacity under different indoor/outdoor DB / WB temperature

Indoor air inlet DB temperature °C	Outdoor air inlet WB temperature °C						
	-15	-10	-5	0	6	10	15
16	0.45	0.53	0.65	0.80	1.02	1.13	-
18	0.47	0.55	0.61	0.76	1.02	1.12	-

20	0.46	0.54	0.6	0.75	1	1.11	1.25
21	0.42	0.49	0.59	0.72	0.99	1.1	1.24
22	0.41	0.49	0.58	0.71	0.97	1.09	1.23
24	0.39	0.45	0.56	0.7	0.96	1.08	1.22

Actual heating capacity calculation:

Actual heating capacity=amendment coefficient of heating capacity × nominal heating capacity

——nominal heating capacity could be found from the performance parameters list

——amendment coefficient of heating capacity could be found from table above.

3.3 Amendment coefficients of heating and cooling capacity under different height drop

Different Cooling Capacity modified coefficients at different height:

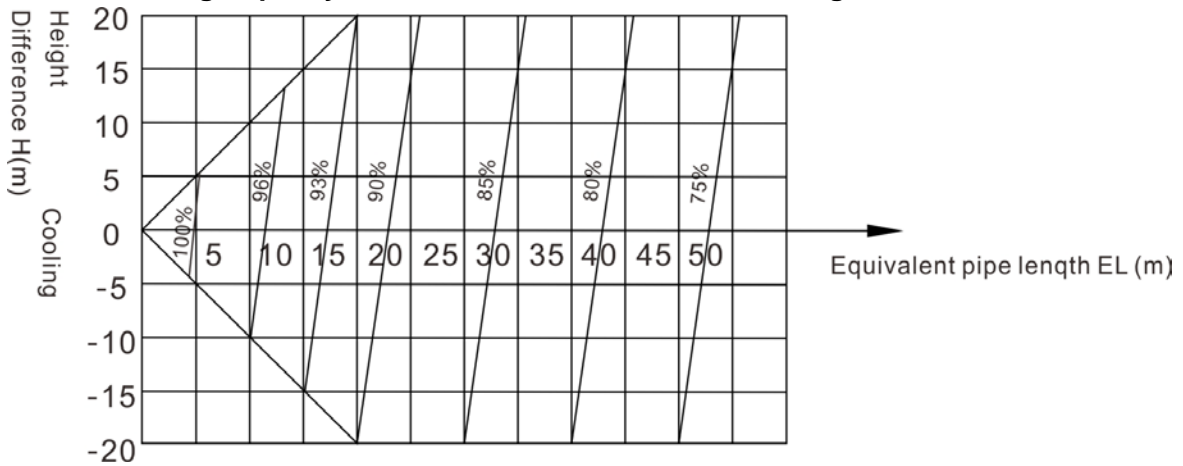

Note: H = Height of Outdoor Unit — Height of Indoor Unit

Different Heating Capacity modified coefficients at different height:

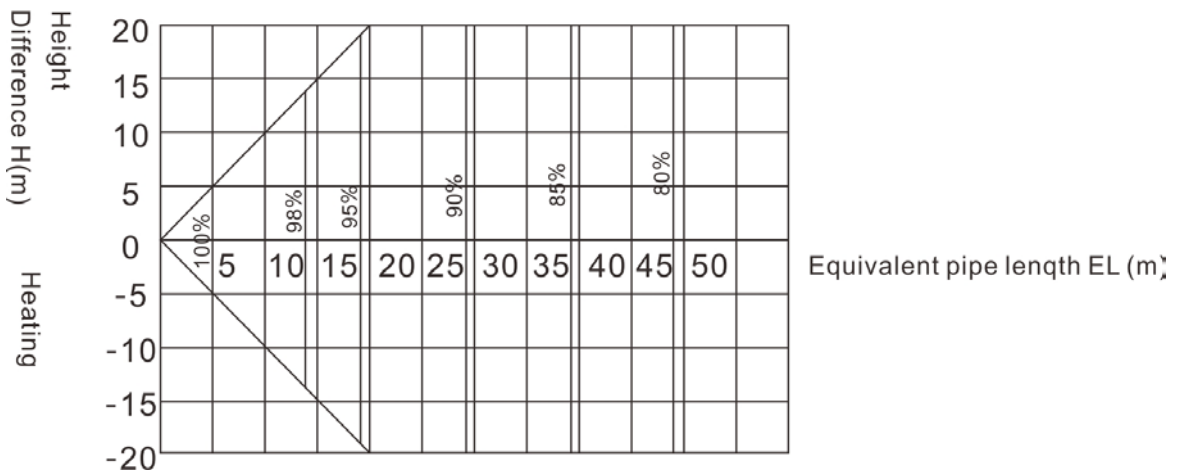

Note: H = Height of Outdoor Unit — Height of Indoor Unit

4. Demension

ALCF-H18/4R1C,

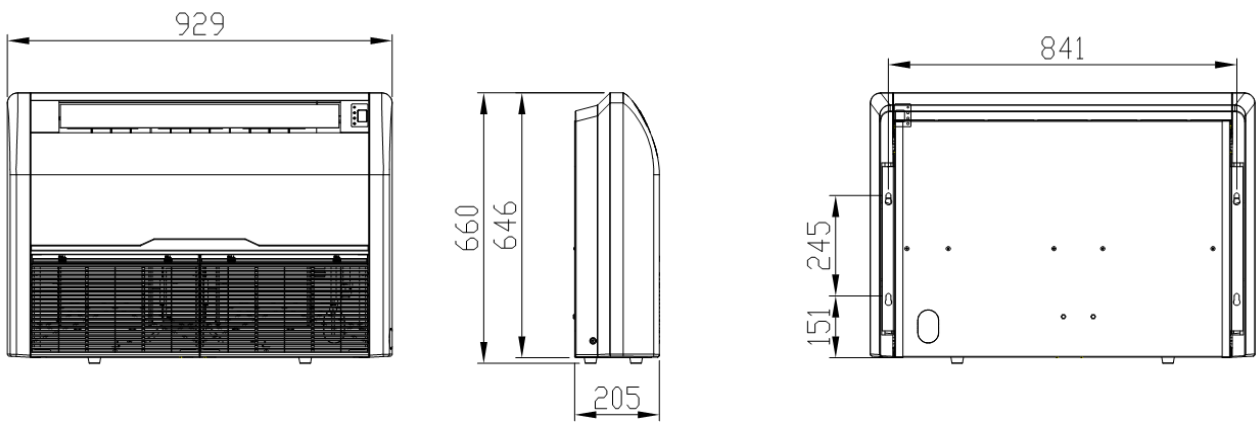

ALCF-H24/4R1C, ALCF-H36/4R1, ALCF-H36/5R1C

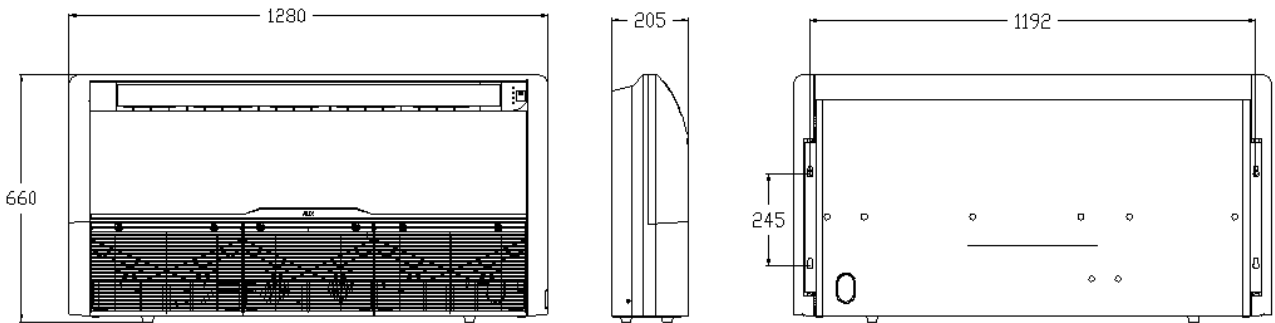

ALCF-H48/5R1C, ALCF-H60/5R1C

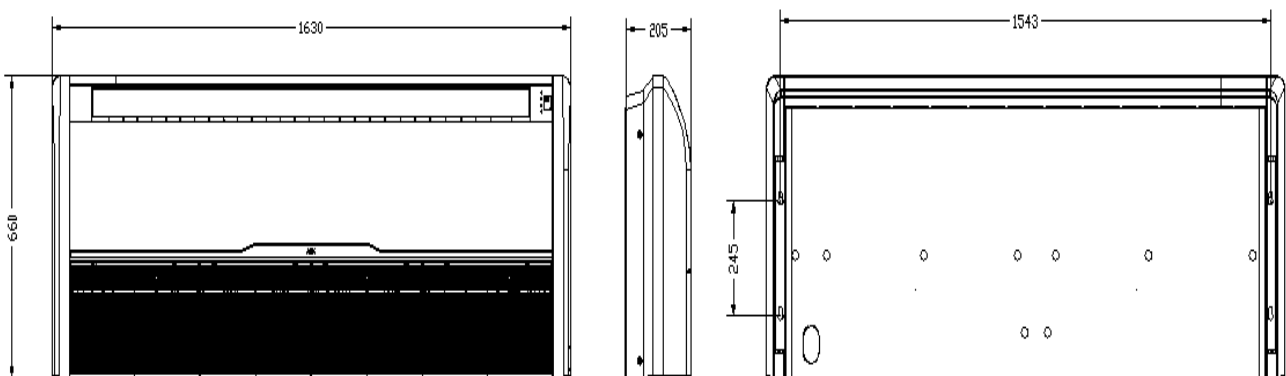

5. Electrical wiring and connection

ALCF-H18/4R1C

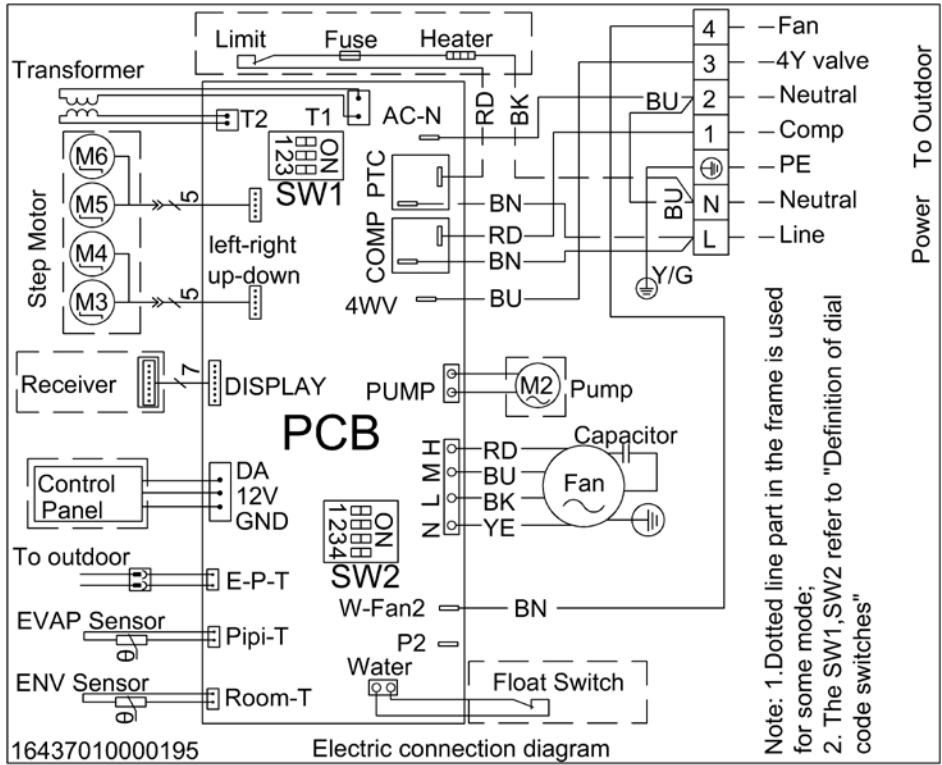

ALCF-H24/4R1C

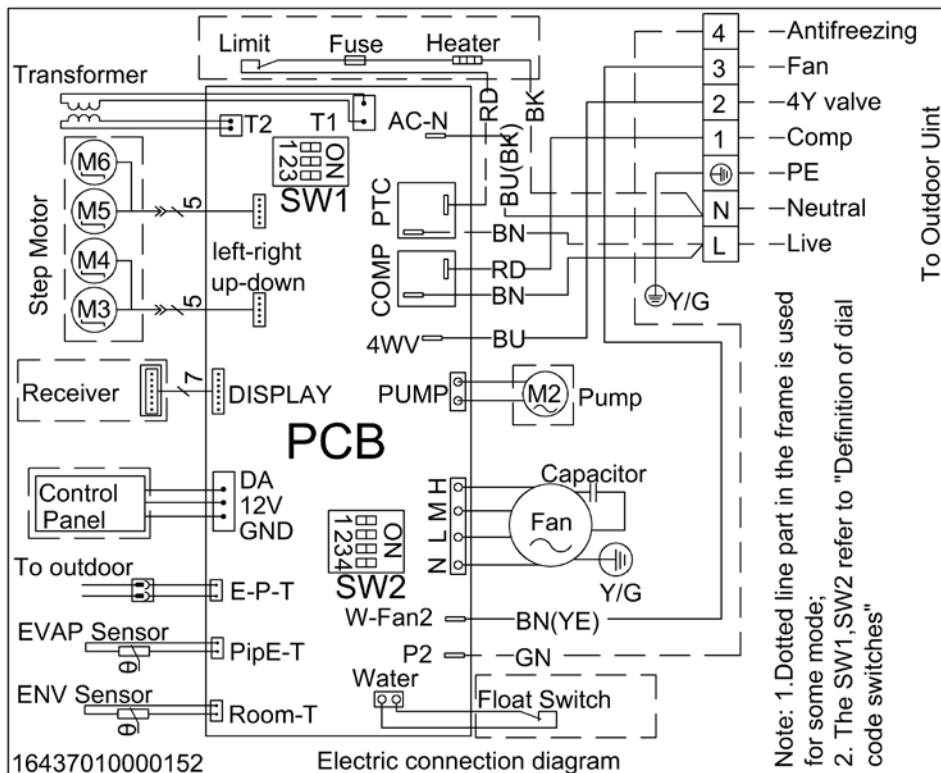

ALCF-H36/4R1 ,ALCF-H36/5R1C, ALCF-H48/5R1C, ALCF-H60/5R1C

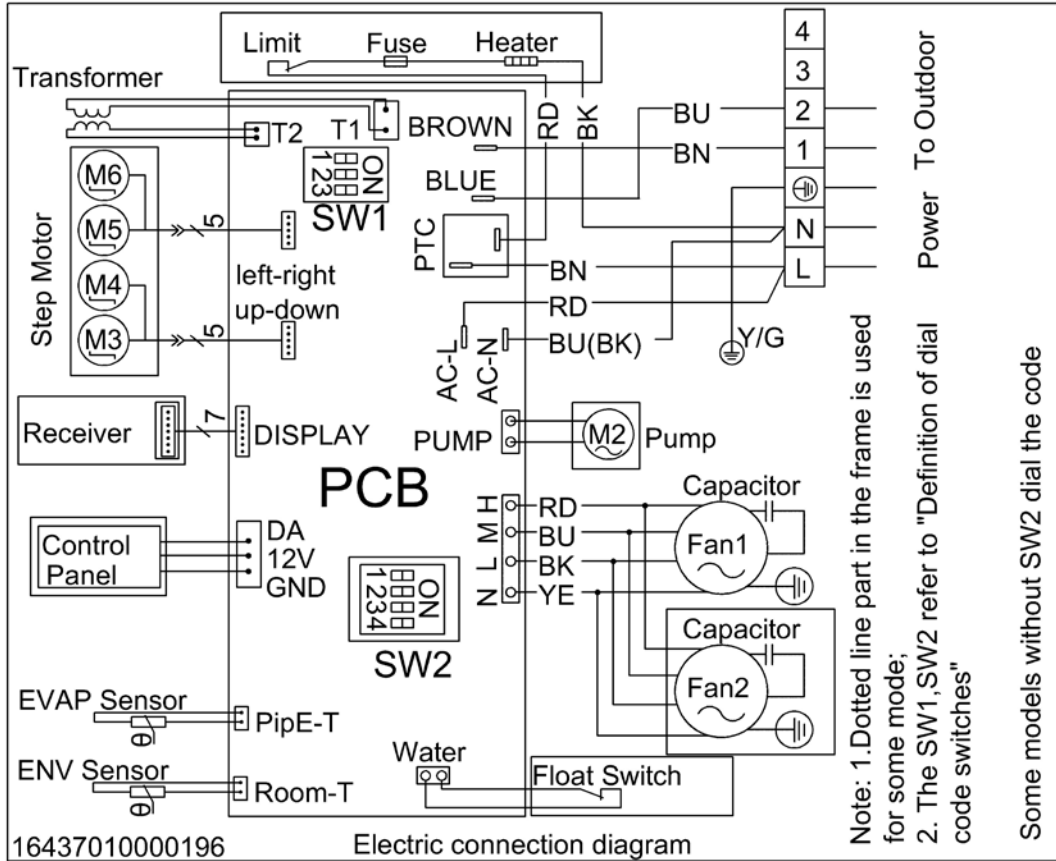

Electrical connection

ALCF-H18/4R1C

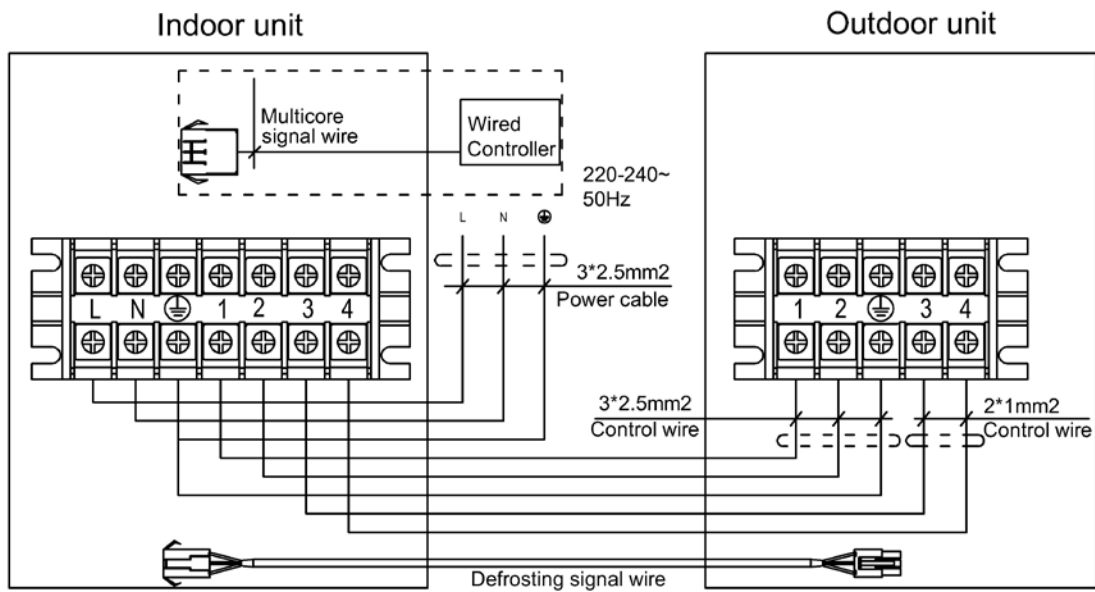

ALCF-H24/4R1C

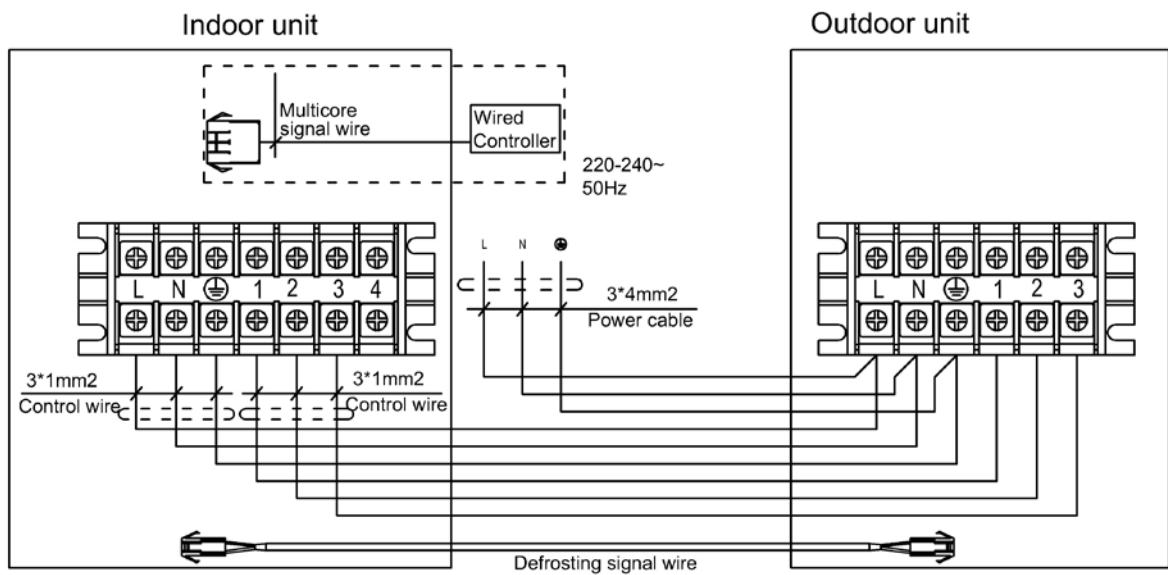

ALCF-H36/4R1

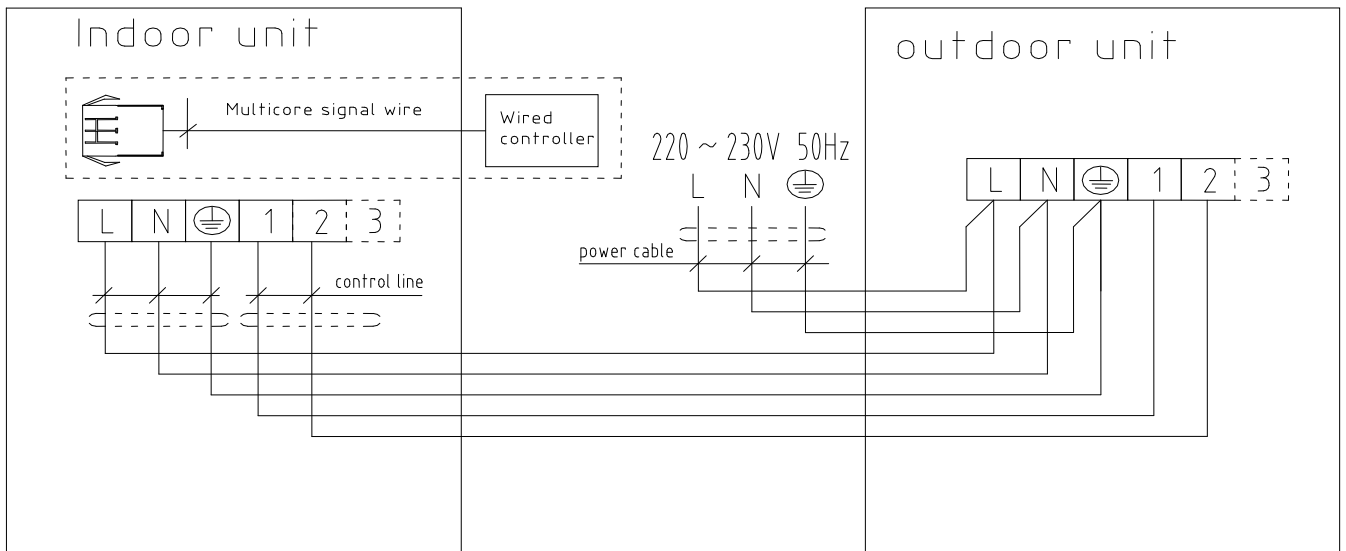

ALCF-H36/5R1C, ALCF-H48/5R1C, ALCF-H60/5R1C

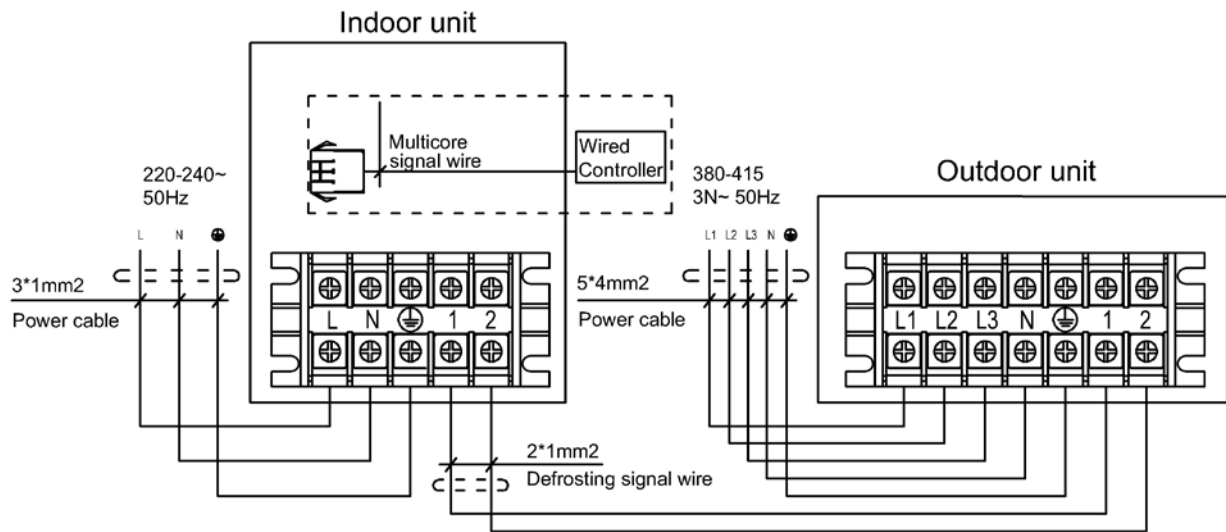

Introduction of Control Board QRDL-3F(2S)-SYE1 (indoor unit) (match with the outdoor unit which the Power supply is 220V-240V, 1PH)

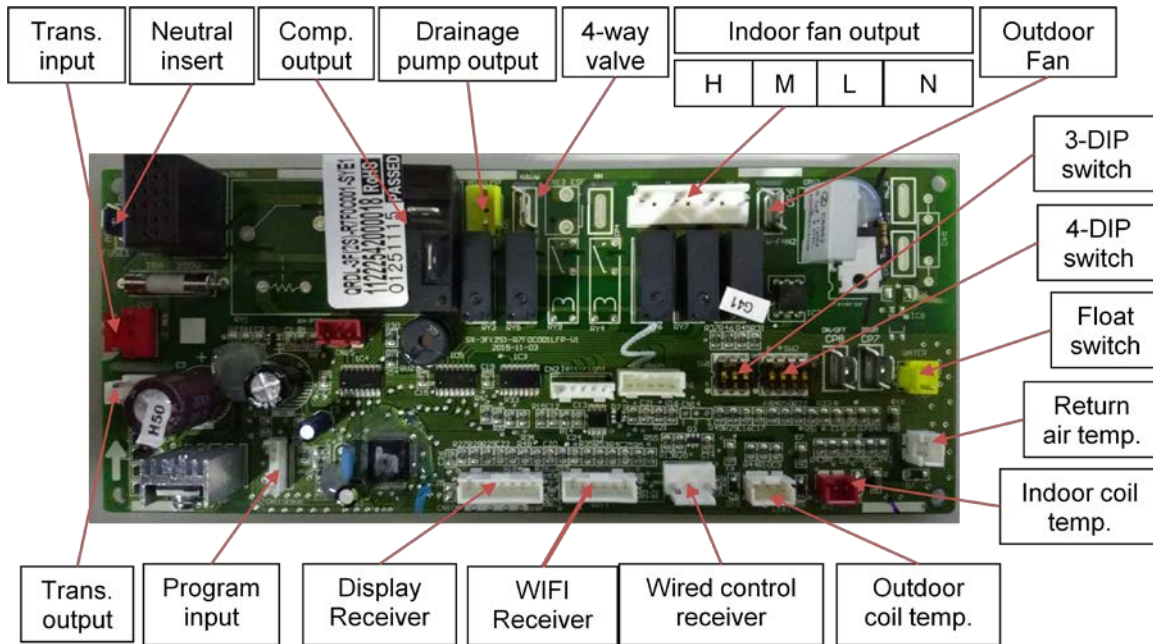

Introduction of control board QRD-SN3F(EX)-SYE1 sockets (Indoor unit) (match with the outdoor unit which the Power supply is 380V-415V, 3PH)

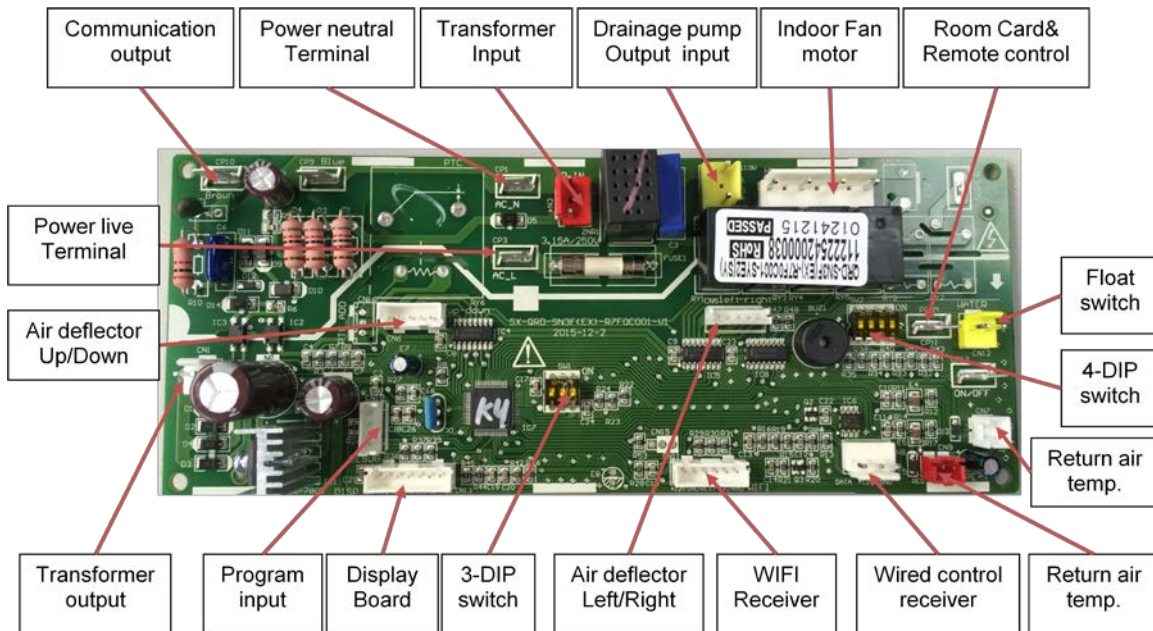

6.Installation

6.1 Preparation and equipments before installation

Please buy following spare parts from your local market before installation	Besides general implements, other implements are needed when connecting the pipe
Hung bolts M12, 4 pcs	Acetylene cylinders, oxygen cylinders (when longer pipe used it should be welded)
Drainage pipe PVC	One set pipe cut machine. (cut copper pipe)
Copper connecting pipe	Refrigerant cans, electronic balance (when longer pipe used additional gas should be charged)
Adhesive belt (big size) 5 pcs, (small size) 5 pcs	Pressure gauges, pipe clamp, welding torch, 2B silver electrode
Heat insulation material used to connect copper pipe (PE foam material, its thickness is more than 8mm)	Wrench 2 pcs, one of them is with adjustable torque wrench (42N.m,65N.m,100N.mm)
Power cable, electrical wire between indoor and outdoor unit(Must be in accordance with the wire diameter in the wiring diagram)	Nitrogen cylinder (in order to prevent oxidation when welding, using Nitrogen to replace the air)

6.2 The distance between indoor unit and obstacle

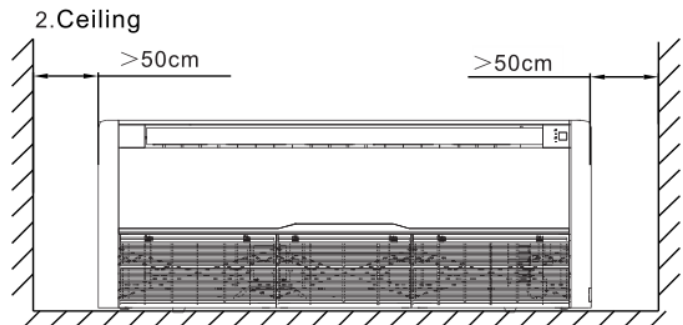
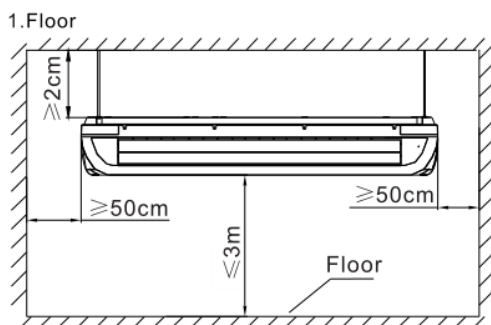

6.3 Indoor unit suspension

- ◇ Select the suspension foundation
- ◇ The suspension foundation is a structure of either wooden frame or reinforced concrete. It must be firm and reliable to bear at least 4 times weight of itself and capable of bearing vibration for long periods;
Fixing of suspension foundation
- ◇ Fix the suspension bolts either as shown in the picture or by a steel or wooden bracket;
- ◇ Adjust the relative positions of the suspension hooks to ensure the indoor unit is level in all directions. Use a spirit level to ensure this, otherwise water leakage, air leakage etc. will be resulted;
- ◇ Tighten the nuts and ensure that the hooks are tightly connected to the nuts and sMDms, and there is no phenomenon of virtual hanging;
- ◇ After the unit is installed ensure it is secure and does not shake or sway.

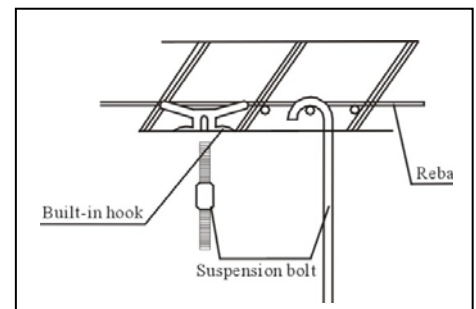

6.4 Drainage pipe installation

- ◇The drain pipe should be properly insulated to prevent the generation of condensation, see picture as follows:

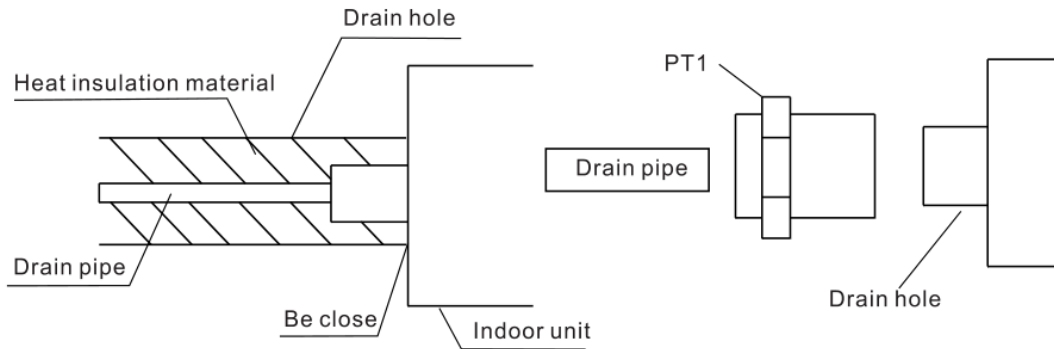

Heat insulation material: rubber insulation pipe with the thickness of more than 8mm

- ◇Drainage pipe must have a downward gradient (1 / 50 1 / 100).If the drain pipe is installed ups and downs, it will cause water backflow or leakage etc.

The pipe should not rise at any point.

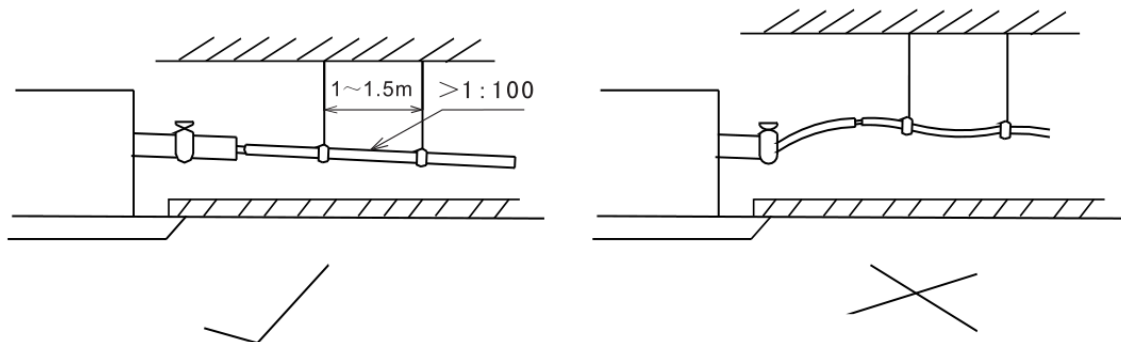

- ◇When finish installation,please carry out the drainage test to ensure that the water flow through the pipeline fluently, and carefully observe the junction to ensure that there is no water leakage at the junction. If the unit is installed in the newly built house, strongly recommend that this test taken before the ceiling installation. Even it is the heating only unit, this test is unavoidable.

7.Explode view ALCF-H18/4R1C

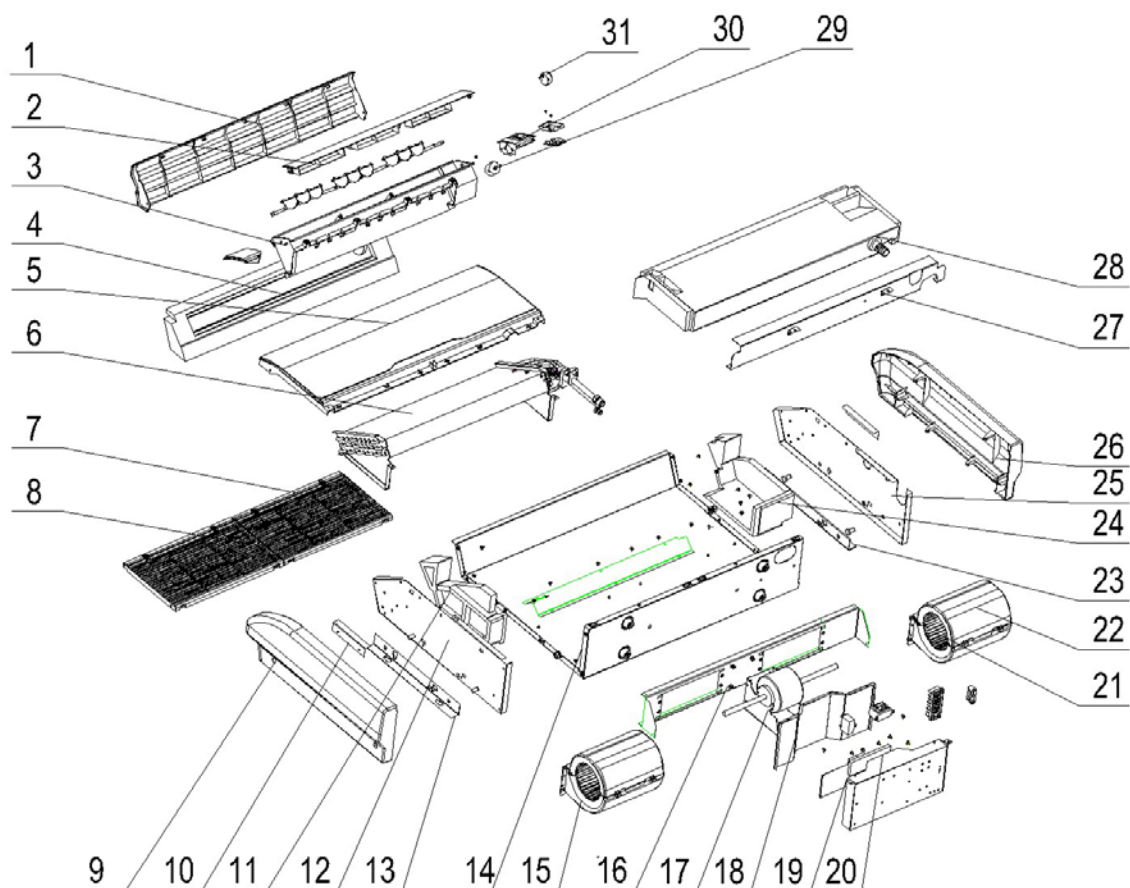

NO.	Chinese name	Part Name	Quantity
1	ALCe-H18A4/C5 顶盖板	The top covers	1
2	导风门 ALCe-H18A4/C5	Sway a breeze leaf	1
3	ALCe-H18A4/C5 导风架组件	Air guide louver assembly	1
4	ALCe-H18A4/C5 顶泡沫	The top foam	1
5	ALCe-H18A4/C5 面板	Panel	1
6	ALCe-H18A4/R1DCC5 蒸发器总成	Evaporator assembly	1
7	ALCe-H24B4/C5 格栅	Air-inlet grill	2
8	ALCe-H24B4/C5 滤网	Air-inlet filter	2
9	ALCe-H24B4/C5 左盖板	The left side covers	1
10	ALCe-H24B4/C5 集水盘压板	Draining tray plate	2
11	ALCe-H24B4/C5 左泡沫(开模)	Left foam	1
12	ALCe-H24B4/C5 左侧板组件	Left side panel assembly	1
13	ALCe-H24B4/C5 左挂架	Left suspend plate	1

14	ALCe-H18A4/C5 背板	Chassis welding assembly	1
15	风轮 $\phi 145 \times 190 \times \phi 12$	fan	2
16	ALCe-H18A4/C5 电机固定板	Volute fixing board	1
17	直流电机 FP40A-ZL(12 轴径)	motor	1
18	DR-120N/DC5-A 电控盒盖	The electronic control box cover	1
19	CJ 控制板 DCZ-OXNX-SN1T1(18-60)K-SYE	PCB board	1
20	CJ 控制板 DCZ-OXNX-SNPOWER-C-SYE	PCB board	1
21	上涡壳 ALCe-H24B4/C5(白色)	Volute assembly	2
22	下涡壳 ALCe-H24B4/C5(白色)	Volute assembly	2
23	ALCe-H24B4/C5 右挂架	Right suspend plate	1
24	ALCe-H24B4/C5 右泡沫(开模)	Right foam	1
25	ALCe-H24B4/C5 右侧板组件	Right side panel assembly	1
26	ALCe-H24B4/C5 右盖板	The Right side covers	1
27	ALCe-H18A4/C5 集水盘固定板组件	Draining tray fixed plate	1
28	ALCe-H18A4/C5 集水盘组件	Draining tray	1
29	步进电机 35BYJ46-QC120	Step motor	1
30	ALCe-H24B4/C5 显示盒组件	Display board cover	1
31	(ROHS)步进电机 35BYJ46-QC50	Step motor	1

ALCF-H24/4R1C

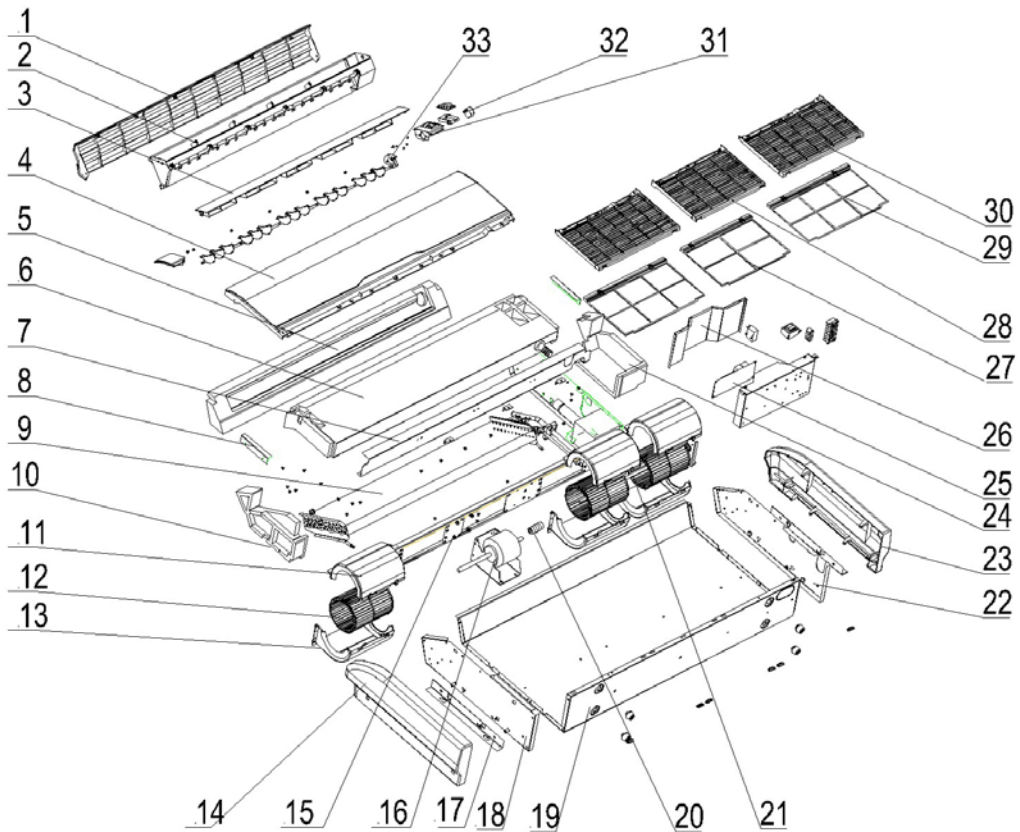

ALCF-H24/4R1C

NO.	Chinese name	Part Name	Quantity
1	ALCe-H24B4/C5 顶盖板	The top covers	1
2	ALCe-H24B4/C5 导风架组件	Air guide louver assembly	1
2.1	ALCe-H24B4/C5 导风架	Air guide louver	1
3	导风门 ALCe-H24B4/C5	Sway a breeze leaf	1
4	ALCe-H24B4/C5 面板	Panel	1
5	ALCe-H24B4/C5 顶泡沫	The top foam	1
6	ALCe-H24B4/C5 集水盘组件	Draining tray	1
7	ALCe-H24B4/C5 集水盘固定板组件	Draining tray fixed plate	1
8	ALCe-H24B4/C5 集水盘压板	Draining tray plate	2
9	ALCE-H24A4/R1DCC5-B6 蒸发器总成	Evaporator assembly	1
10	ALCe-H24B4/C5 左泡沫(开模)	Left foam	1
11	上涡壳 ALCe-H24B4/C5(白色)	Volute assembly	3
12	风轮 φ145×190×φ15(白色)	fan	3
13	下涡壳 ALCe-H24B4/C5(白色)	Volute assembly	3
14	ALCe-H24B4/C5 左盖板	The left side covers	1
15	ALCe-H24B4/C5 电机固定板	Volute fixing board	1

16	直流电机 FP90A-ZL(长短轴)	Moter	1
17	ALCe-H24B4/C5 左挂架	Left suspend plate	1
18	ALCe-H24B4/C5 左侧板组件	Left side panel assembly	1
19	ALCe-H24A4/R1DCC5-B6 背板组件	Chassis welding assembly	1
20	联轴器 φ15	Motor coupling	1
21	加长轴 φ15×565	Motor lengthen axes	1
22	ALCe-H24B4/C5 右侧板组件	Right side panel assembly	1
23	ALCe-H24B4/C5 右挂架	Right suspend plate	1
24	ALCe-H24B4/C5 右盖板	The Right side covers	1
25	ALCe-H24B4/C5 右泡沫(开模)	Right foam	1
26.1	CJ 控制板 DCZ-OXNX-SN1T1(18-60)K-SYE	PCB board	1
26.2	CJ 控制板 DCZ-OXNX-SNPOWER-C-SYE	PCB board	1
27	DR-120N/DC5-A 电控盒	The electronic control box	1
28	ALCe-H24B4/C5 中滤网	Filter In the center	1
29	ALCe-H24B4/C5 中格栅	Air-inlet grill	1
30	ALCe-H24B4/C5 滤网	Air-inlet filter	2
31	ALCe-H24B4/C5 格栅	Air-inlet grill	2
32	ALCe-H24B4/C5 显示盒组件	Display board cover	1
33	(ROHS)步进电机 35BYJ46-QC50	Step motor	1
34	步进电机 35BYJ46-QC120	Step motor	1

ALCF-H36/4R1,ALCF-H36/5R1C

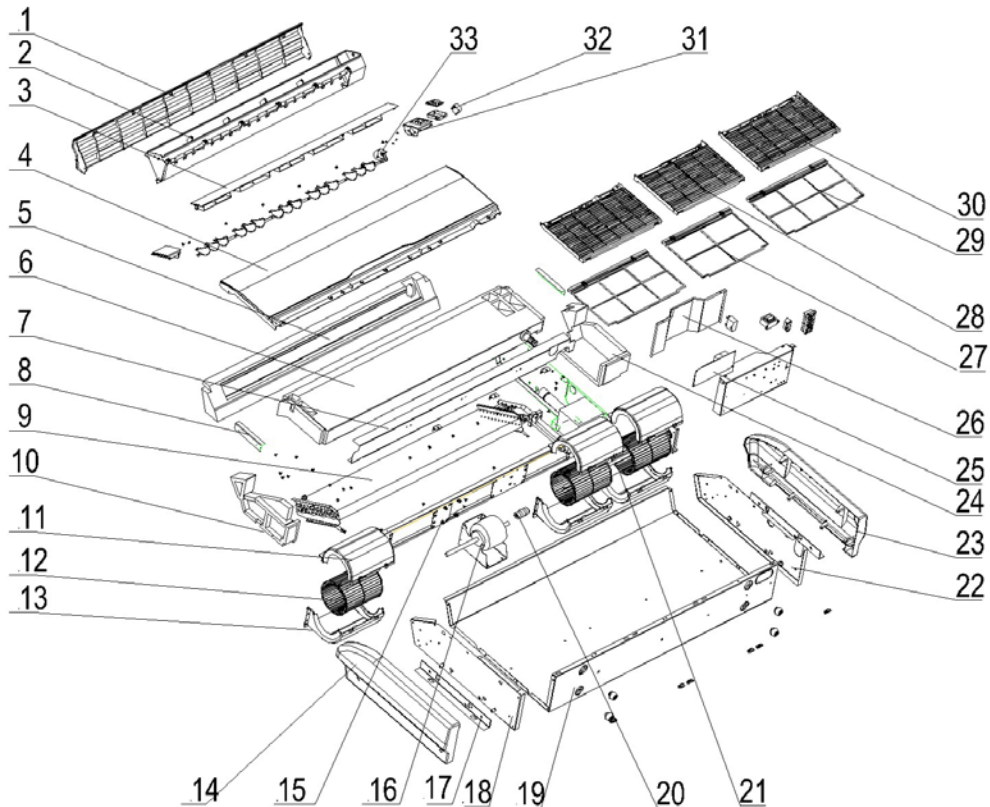

ALCF-H36/4R1,ALCF-H36/5R1C

NO.	Chinese name	Part Name	Quantity
1	ALCe-H24B4/C5 顶盖板	The top covers	1
2	ALCe-H24B4/C5 导风架组件	Air guide louver assembly	1
2.1	ALCe-H24B4/C5 导风架	Air guide louver	1
3	导风门 ALCe-H24B4/C5	Sway a breeze leaf	1
4	ALCe-H24B4/C5 面板	Panel	1
5	ALCe-H24B4/C5 顶泡沫	The top foam	1
6	ALCe-H24B4/C5 集水盘组件	Draining tray	1
7	ALCe-H24B4/C5 集水盘固定板组件	Draining tray fixed plate	1
8	ALCe-H24B4/C5 集水盘压板	Draining tray plate	2
9	ALCE-H24A4/R1DCC5-B6 蒸发器总成	Evaporator assembly	1
10	ALCe-H24B4/C5 左泡沫(开模)	Left foam	1
11	上涡壳 ALCe-H24B4/C5(白色)	Volute assembly	3
12	风轮 $\phi 145 \times 190 \times \phi 15$ (白色)	fan	3
13	下涡壳 ALCe-H24B4/C5(白色)	Volute assembly	3
14	ALCe-H24B4/C5 左盖板	The left side covers	1
15	ALCe-H24B4/C5 电机固定板	Volute fixing board	1
16	直流电机 FP90A-ZL(长短轴)	Moter	1
17	ALCe-H24B4/C5 左挂架	Left suspend plate	1

18	ALCe-H24B4/C5 左侧板组件	Left side panel assembly	1
19	ALCe-H24A4/R1DCC5-B6 背板组件	Chassis welding assembly	1
20	联轴器 φ15	Motor coupling	1
21	加长轴 φ15×565	Motor lengthen axes	1
22	ALCe-H24B4/C5 右侧板组件	Right side panel assembly	1
23	ALCe-H24B4/C5 右挂架	Right suspend plate	1
24	ALCe-H24B4/C5 右盖板	The Right side covers	1
25	ALCe-H24B4/C5 右泡沫(开模)	Right foam	1
26.1	CJ 控制板 DCZ-OXNX-SN1T1(18-60)K-SYE	PCB board	1
26.2	CJ 控制板 DCZ-OXNX-SNPOWER-C-SYE	PCB board	1
27	DR-120N/DC5-A 电控盒	The electronic control box	1
28	ALCe-H24B4/C5 中滤网	Filter In the center	1
29	ALCe-H24B4/C5 中格栅	Air-inlet grill	1
30	ALCe-H24B4/C5 滤网	Air-inlet filter	2
31	ALCe-H24B4/C5 格栅	Air-inlet grill	2
32	ALCe-H24B4/C5 显示盒组件	Display board cover	1
33	(ROHS)步进电机 35BYJ46-QC50	Step motor	1
34	步进电机 35BYJ46-QC120	Step motor	1

ALCF-H48/5R1C, ALCF-H60/5R1C

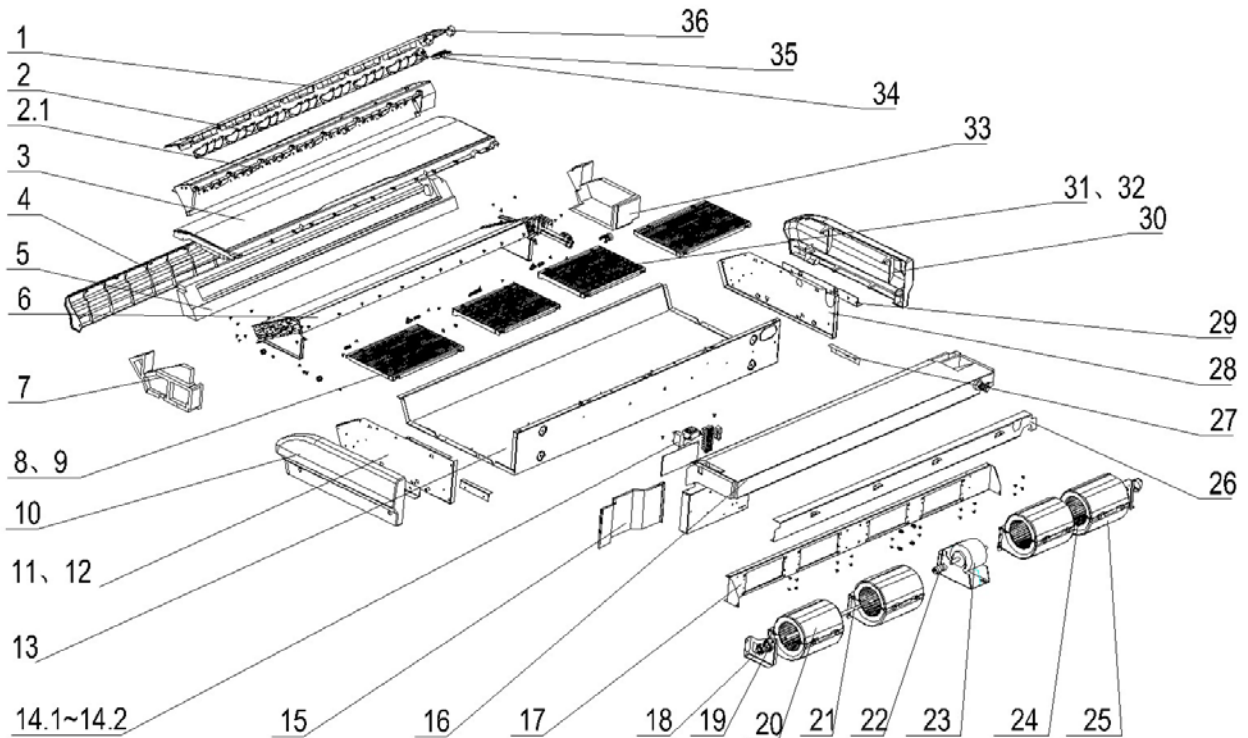

ALCF-H48/5R1C, ALCF-H60/5R1C

N0.	Chinese name	Part Name	Quantity
1	导风门 ALCe-H42A5/C5	Sway a breeze leaf	2
2	ALCe-H42A5/C5 导风架组件	Air guide louver assembly	2
2.1	ALCe-H42A5/C5 导风架	Air guide louver	2
3	ALCe-H42A5/C5 面板	Panel	2
4	ALCe-H42A5/C5 顶盖板	The top covers	1
5	ALCe-H42A5/C5 顶泡沫	The top foam	1
6	ALCe-H60A5/C5 蒸发器总成 (片距 1.6)	Evaporator assembly	1
7	ALCe-H24B4/C5 左泡沫(开模)	Left foam	1
8	ALCe-H24B4/C5 格栅	Air-inlet grill	1
9	ALCe-H24B4/C5 滤网	Air-inlet filter	1
10	ALCe-H24B4/C5 左盖板	The left side covers	1
11	ALCe-H24B4/C5 左侧板组件	Left side panel assembly	1
12	ALCe-H24B4/C5 左挂架	Left suspend plate	1

13	DR-140N/DC5-A 背板组件	Chassis welding assembly	4
14.1	CJ 控制板 DCZ-OXNX-SN1T1(18-60)K- SYE	PCB board	1
14.2	CJ 控制板 DCZ-OXNX-SNPOWER-C-S YE	PCB board	1
15	DR-120N/DC5-A 电控盒盖	The electronic control box cover	1
16	ALCe-H42A5/C5 集水盘组件	Draining tray	1
17	ALCe-H42A5/C5 电机固定板	Volute fixing board	1
18	橡胶轴承 GR-50D/DC2	Rubber bearings	1
19	GR-50D/DC2 橡胶轴承压板	Bearing top cover	1
20	上涡壳 ALCe-H24B4/C5(白 色)	Volute assembly	1
21	加长轴 $\phi 15 \times 565$	Motor lengthen axes	1
22	联轴器 $\phi 15$	Motor coupling	1
23	直流电机 FP150B-ZL	Motor	1
24	风轮 $\phi 145 \times 190 \times \phi 15$ (白色)	Fan	1
25	下涡壳 ALCe-H24B4/C5(白 色)	Volute assembly	1
26	ALCe-H42A5/C5 集水盘固定 板组件	Draining tray fixed plate	21
27	ALCe-H24B4/C5 集水盘压板	Draining tray plate	1
28	ALCe-H24B4/C5 右侧板组件	Right side panel assembly	1
29	ALCe-H24B4/C5 右挂架	Right suspend plate	1
30	ALCe-H24B4/C5 右盖板	The Right side covers	1
31	ALCe-H24B4/C5 中格栅	Air-inlet grill	1
32	ALCe-H24B4/C5 中滤网	Filter In the center	1
33	ALCe-H24B4/C5 右泡沫(开 模)	Right foam	1
34	步进电机 35BYJ46-QC120	Step motor	1
35	ALCe-H24B4/C5 显示盒组件	Display board cover	2
35	ALCe-H24B4/C5 右装饰板组 件	Right plate assembly	2
36	(ROHS)步进电机 35BYJ46-QC50	Step motor	1

Middle static pressure duct type

1.Feature.....	58
2.Specification	60
3.Capacity amendment	64
4.Dimension	66
5.Electrical wiring and connection.....	67
6.Fan performance.....	72
7.Installation.....	74
8.Explode view.....	77

1.Feature

Duct type air conditioner (Cooling-only or Heat pump), named for the Duct can be installed to connect with air outlet and inlet. According to different ESP, it divides into Low ESP Duct type (12~30Pa), Medium ESP Duct type (50~80Pa) and high ESP Duct type (higher than 80Pa).

Application occasions:

Small super market, hotel, restaurant, office, meeting room and so on.

Features:

- ◇ Conceal design, the unit is installed inside of ceiling, doesn't take room space, suitable for family and office place;
- ◇ With Setting or Auto two operation modes, multi speed wind, makes you feel more comfortable;
- ◇ There are red and white two terminals for motor wiring, users can adjust the ESP by changing the terminals to meet different requirements, simple and convenient; Low ESP Duct is 12/30Pa, and Medium ESP Duct is 50/80Pa, the default setting is 12/30Pa;
- ◇ Special insulation design, achieves high heat insulation efficiency, and no condensation on shell;
- ◇ Low noise centrifugal fan, strong wind but quiet operation;
- ◇ 3-phase power supply type units with low ambient temperature cooling function, which makes the unit can run normally on the condition that the ambient temperature falls down to -15°C;
- ◇ Auto restart;
- ◇ Standard wired controller and optional remote controller;
- ◇ Auxiliary electric heater for heat pump unit, with fast heating and low ambient temperature heating functions;
- ◇ Failure automatic detection, if there is a failure, the indicator will flash and the failure code will display on the wired controller, the failure cause is easier to be found..

Function introduction

Type	Item	ALMD-H**R1D					
		18/4	24/4	36/4	36/5	48/5	60/5
Protection	High pressure protection	-	-	—	●	●	●
	Low pressure protection	-	-	—	●	●	●
	Compressor overload protection	●	●	●	●	●	●
	Exhaust high temperature protection	-	-	—	●	●	●
	Phase protection(Phase-loss, phase- reverse)	-	-	—	●	●	●
	Overheating protection	●	●	●	●	●	●
	Prevent frostbite protection	●	●	●	●	●	●
	Sensor failure alarm	●	●	●	●	●	●
	Malfunction code display function	●	●	●	●	●	●
Comfort	Cooling	●	●	●	●	●	●
	Heating	●	●	●	●	●	●
	Three speed	●	●	●	●	●	●
	Adjusted static pressure	-	-	—	-	-	-
	Auto- restart function(Optional)	●	●	●	●	●	●
	Anti-cold wind	●	●	●	●	●	●
	Afterheat wind blowing	●	●	●	●	●	●
	Timing on/off function	●	●	●	●	●	●
Operating	Clock display	●	●	●	●	●	●
	Running mode display	●	●	●	●	●	●
	Fan speed display	●	●	●	●	●	●
	Defrost display	●	●	●	●	●	●
	Timing on/off display	●	●	●	●	●	●
	Wind angle display	●	●	●	●	●	●
	Sleeping display	●	●	●	●	●	●
Running	Automatic running	●	●	●	●	●	●
	Dehumidify running	●	●	●	●	●	●
	Automatic defrost	●	●	●	●	●	●
	Ventilation function	●	●	●	●	●	●
	Low ambient cooling function	●	●	●	●	●	●
Health	Washable air filter	●	●	●	●	●	●
	Fresh air interface	●	●	●	●	●	●
Installation	Left /right drainage	-	-	—	-	-	-
	Left /right pipe connection	-	-	—	-	-	-
	Back/down air suction	-	-	—	-	-	-
	Guide board for collocating and installation	-	-	—	-	-	-

Remarks: ● Stands for “YES”

- Stands for “NO”

2.Specification

Model	Indoor		ALMD-H18/4R1D	ALMD-H24/4R1D	ALMD-H36/4R1
	Outdoor		AL-H18/4R1D(U)	AL-H24/4R1D(U)	AL-H36/4R1(U)
Factory Model	Indoor		ALHi-H18A4/R1S 3-B7	ALHi-H24B4/R1S3- B7	ALHi-H36A4/R1-S 3
	Outdoor		AL-H18A4/R1(T)- B7	AL-H24A4/R1(T)-B7	AL-H36A4/R1(T)
Code	Indoor		16113022000047	16113022000043	16113022000025
	Outdoor		16107022000019	16107022000018	16107022000001
Power Supply		V~,Hz, Ph	220~240,50,1	220~240,50,1	220~240,50,1
Capacity	Cooling	Btu/h	18000	24000	36000
		kW	5.3	7.2	10.6
	Heating	Btu/h	20000	27500	37500
		kW	5.8	8.1	10.9
Electric Data	Rated Cooling Power Input	kW	1.73	2.39	3.62
	Rated Heating Power Input	kW	1.79	2.35	3.59
	Rated Cooling Current	A	7.95	10.37	6.80
	Rated Heating Current	A	8.22	10.89	6.50
Performance	EER	W/W	3.06	3.01	2.81
	COP	W/W	3.24	3.44	3.34
Indoor Fan Fotor	Model		YSK100-4	YSK160-4	YSK180-4
	Brand		Weiling	Sanxiang/Kangbao	Kangbao
	Output Power x Fan quantity	W	100	160	180
	Capacitor	uF	4	2.5	6
	Speed (Hi/Mi/Lo)	r/min	960/860/840	1050/1000/910	1200/1120/1060
Indoor Coil	Number Of Row		2	3	3
	Tube Pitch(a)x Row Pitch(b)	mm	20.5×12.7	20.5×12.7	20.5×12.7
	Fin Spacing	mm	1.5	1.6	1.6
	Fin Material		Hydrophilic aluminum fin		
	Tube Outside Dia.and Material	mm	φ7 , Inner grooved	φ7 , Inner grooved	φ7,Inner grooved
	Coil Length x Height x Width	mm	625×369×25.4	625×369×38.1	625×369×38.1
	Heat Exchanging Area	m ²	6.98	9.87	9.87
Indoor Unit	Indoor Air Flow (Hi/Mi/Lo)	m ³ /h	1000/800/700	1400/1120/980	2000/1600/1400
	Noise Level(Hi/Mi/Lo)	dB(A)	44/41/35	47/44/38	50/47/41
	External Static Pressure	Pa	50/80	50/80	50/80
	Net Dimension (W*H*D)	mm	890×785×290	890×785×290	890×785×290
	Packing Dimension(W*H*D)	mm	1100×870×360	1100×870×360	1100×870×360

	Net Weight	Kg	34	36	36
	Gross Weight	Kg	40	42	42
Refrigerant Pipe	Liquid Side	mm	6.35	9.52	9.52
	Gas Side	mm	12.7	15.88	15.88
	Max. Refrigerant Pipe Length	m	20	30	50
	Max. Difference In Level	m	15	15	30
Operation Temperature Range		°C	16~32	16~32	16~32
Ambient Temperature Range(Cooling/Heating)		°C	-15~49/-15~24	-15~49/-15~24	-5~49/-15~24
Application Area		m ²	21-35	28-47	21-35
Connection Wiring	Power Wiring(Indoor)	mm ²	3×2.5mm ²	/	3×4mm ²
	Power Wiring(Outdoor)	mm ²	/	3×6mm ²	5×4mm ³
	Signal Wiring	mm ²	3×2.5mm ² +2×1m m ²	3×2.5mm ² +3×1mm ²	3×2.5 mm ² +1 mm ²
Wireless Remote Controller			XK-02	XK-02	XK-02
Qty'per 20'& 40'&40HQ(Only For Reference)		Set	43/95/110	36/78/94	35/72/82

Note:

1. Working condition of the cooling capacity measured: Inside the room 27°CDB, WB 19°C; Outside of the room 35°CDB, WB 24; Working condition of the heating capacity measured: Inside the room 20°CDB, Outside of the room 7°CDB, 6°CWB。
2. Parameters above are all measured when the connecting pipe is 5 meters.
3. Parameters above may be modified as product improvement. We keep the right to change the product specifications without prior notice, please take the parameters listed on the nameplate as criterion.

Model	Indoor		ALMD-H36/5R1D	ALMD-H48/5R1D	ALMD-H60/5R1D
	Outdoor		AL-H36/5R1D(U)	AL-H48/5R1D(U)	AL-H60/5R1D(U)
Factory Model	Indoor		ALHi-H36A5/R1S3-B7	ALHi-H48A5/R1S3-B7	ALHi-H60A5/R1S3-B7
	Outdoor		AL-H36A5/R1(T)-B7	AL-H48A5/R1(T)-B7	AL-H60A5/R1(T)-B7
Code	Indoor		16113022000044	16113022000045	16113022000046
	Outdoor		16107022000020	16107022000022	16107022000023
Power Supply		V~,Hz,Ph		380~415,50,3	380~415,50,3
Capacity	Cooling	Btu/h	36000	48000	60000
		kW	10.6	14.0	17.6
	Heating	Btu/h	40000	53000	63500
		kW	11.7	15.5	18.5
Electric Data	Rated Cooling Power Input	kW	3.73	4.87	5.71
	Rated Heating Power Input	kW	3.50	5.13	6.00
	Rated Cooling Current	A	6.69	8.88	10.42
	Rated Heating Current	A	6.28	9.33	10.88
Performance	EER	W/W	2.84	2.87	3.08
	COP	W/W	3.34	3.02	3.08
Indoor Fan Fotor	Model		YSK180-4	YSK180-4	YSK180-4
	Brand		Kangbao	Kangbao	Kangbao
	Output Power x Fan quantity	W	180	180	180
	Capacitor	uF	6	6	6
	Speed (Hi/Mi/Lo)	r/min	1200/1120/1060	1200/1120/1060	1200/1120/1060
Indoor Coil	Number Of Row		3	3	3
	Tube Pitch(a)x Row Pitch(b)	mm	20.5x12.7	20.5x12.7	20.5x12.7
	Fin Spacing	mm	1.6	1.6	1.6
	Fin Material		Hydrophilic aluminum fin		
	Tube Outside Dia.and Material	mm	625x369x38.1	φ7, Inner grooved	φ7, Inner grooved
	Coil Length x Height x Width	mm	9.87	985x369x38.1	985x369x38.1
	Heat Exchanging Area	m ²	2000/1600/1400	15.56	15.56
Indoor Unit	Indoor Air Flow (Hi/Mi/Lo)	m ³ /h	50/47/41	2400/2000/1600	2800/2240/1960
	Noise Level(Hi/Mi/Lo)	dB(A)	50/80	53/50/44	53/50/44
	External Static Pressure	Pa	890x785x290	50/80	50/80
	Net Dimension (W*H*D)	mm	1100x870x360	1250x785x290	1250x785x290
	Packing Dimension (W*H*D)	mm	1100x870x360	1460x870x360	1460x870x360
	Net Weight	Kg	36	52	52

	Gross Weight	Kg	42	59	59
Refrigerant Pipe	Liquid Side	mm	9.52	9.52	9.52
	Gas Side	mm	15.88	19.05	19.05
	Max. Refrigerant Pipe Length	m	50	50	50
	Max. Difference In Level	m	30	30	30
Operation Temperature Range		°C	16~32	16~32	16~32
Ambient Temperature Range(Cooling/Heating)		°C	-15~49/-15~24	-15~49/-15~24	-15~49/-15~24
Application Area		m ²	42-70	42-70	64-107
Connection Wiring	Power Wiring(Indoor)	mm ²	3×1mm ³	3×1mm ³	3×1mm ³
	Power Wiring(Outdoor)	mm ²	5×4mm ³	5×4mm ³	5×4mm ³
	Signal Wiring	mm ²	2×1mm ²	2×1mm ²	2×1mm ²
Wireless Remote Controller			XK-02	XK-02	XK-02
Qty'per 20'& 40'&40HQ(Only For Reference)			35/72/82	21/44/47	21/44/47

Note:

1. Working condition of the cooling capacity measured: Inside the room 27°CDB, WB 19°C; Outside of the room 35°CDB, 24°CWB; Working condition of the heating capacity measured: Inside the room 20°CDB, Outside of the room 7°CDB, 6°CWB。
2. Parameters above are all measured when the connecting pipe is 5 meters.
3. Parameters above may be modified as product improvement. We keep the right to change the product specifications without prior notice, please take the parameters listed on the nameplate as criterion.

3.Capacity amendment

3.1 Running range

Cooling capacity (Btu/h)		18000	24000	36000	48000	60000
Power supply		220~240V/50Hz				
Voltage		187~242V				
Ambient temperature	Cooling	-15~49°C				
	Heating	-15~24°C				

3.2 Amendment coefficient of cooling capacity under different indoor/outdoor DB and WB

Indoor air inlet temperature°C		Outdoor air inlet DB°C							
DB	WB	25	30	35	40	43	45	47	49
23	16	0.98	0.94	0.89	0.85	0.82	0.79	0.74	0.71
25	18	1.05	1	0.95	0.90	0.87	0.82	0.77	0.72
27	19	1.1	1.05	1	0.95	0.91	0.87	0.84	0.79
28	20	1.12	1.07	1.02	0.96	0.93	0.90	0.86	0.81
30	22	1.19	1.13	1.08	1.02	0.99	0.96	0.91	0.88
32	24	1.26	1.20	1.15	1.08	1.05	1.02	0.97	0.92

Actual cooling capacity calculation:

Actual cooling capacity=amendment coefficient of cooling capacity × nominal cooling capacity

——nominal cooling capacity could be found from the performance parameters list

——amendment coefficient of cooling capacity could be found from table above.

3.3 Amendment coefficient of heating capacity under different indoor/outdoor DB and WB

Indoor air inlet DB°C	Outdoor air inlet WB°C						
	-15	-10	-5	0	6	10	15
16	0.45	0.53	0.65	0.80	1.02	1.13	-
18	0.47	0.55	0.61	0.76	1.02	1.12	-
20	0.46	0.54	0.6	0.75	1	1.11	1.25
21	0.42	0.49	0.59	0.72	0.99	1.1	1.24
22	0.41	0.49	0.58	0.71	0.97	1.09	1.23
24	0.39	0.45	0.56	0.7	0.96	1.08	1.22

Actual heating capacity calculation:

Actual heating capacity=amendment coefficient of heating capacity × nominal heating capacity

——nominal heating capacity could be found from the performance parameters list

——amendment coefficient of heating capacity could be found from table above.

3.4 Amendment coefficients of heating and cooling capacity under different height drop

Different Cooling Capacity modified coefficients at different height:

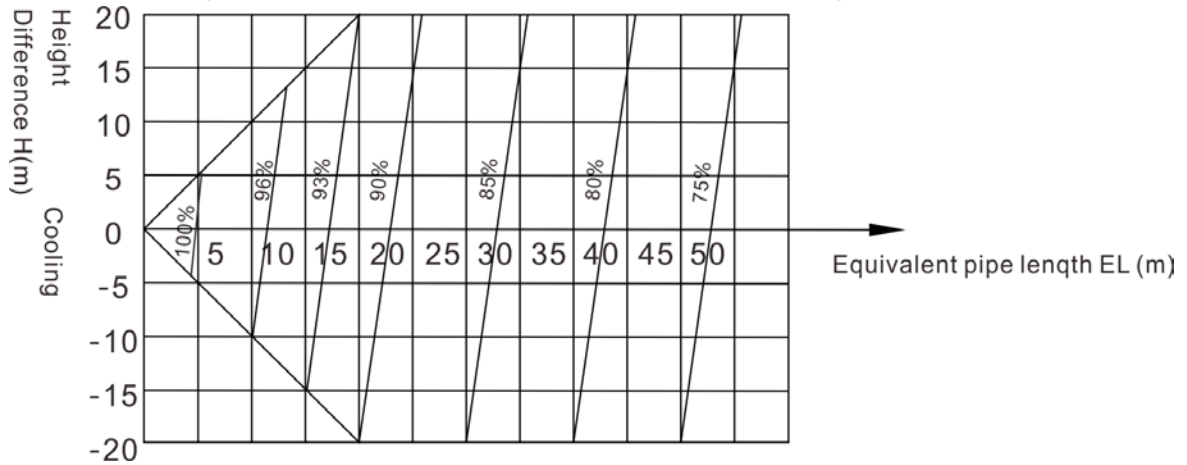

Note: H = Height of Outdoor Unit — Height of Indoor Unit

Different Heating Capacity modified coefficients at different height:

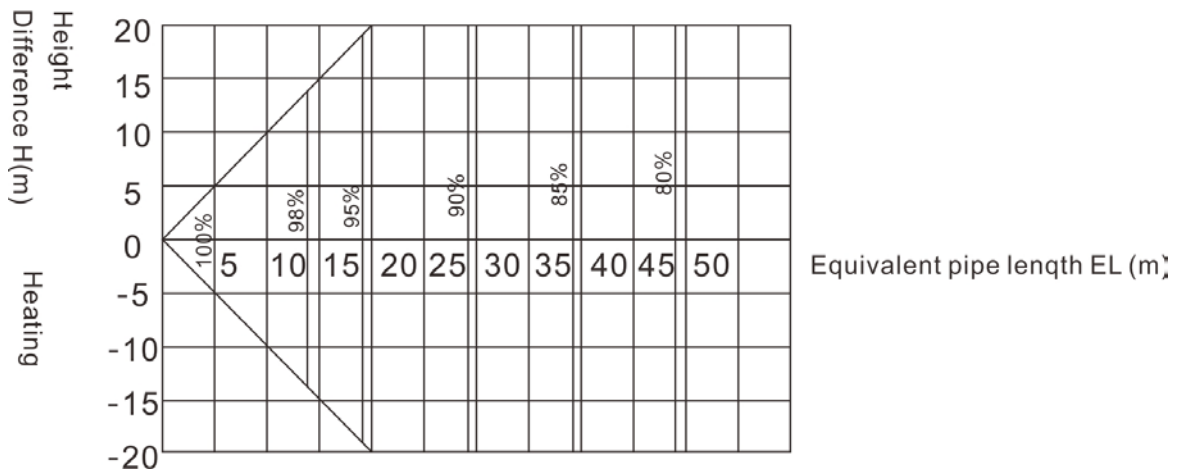

Note: H = Height of Outdoor Unit — Height of Indoor Unit

4.Dimension

ALMD-H18/4R1D, ALMD-H24/4R1D,ALMD-H36/5R1D

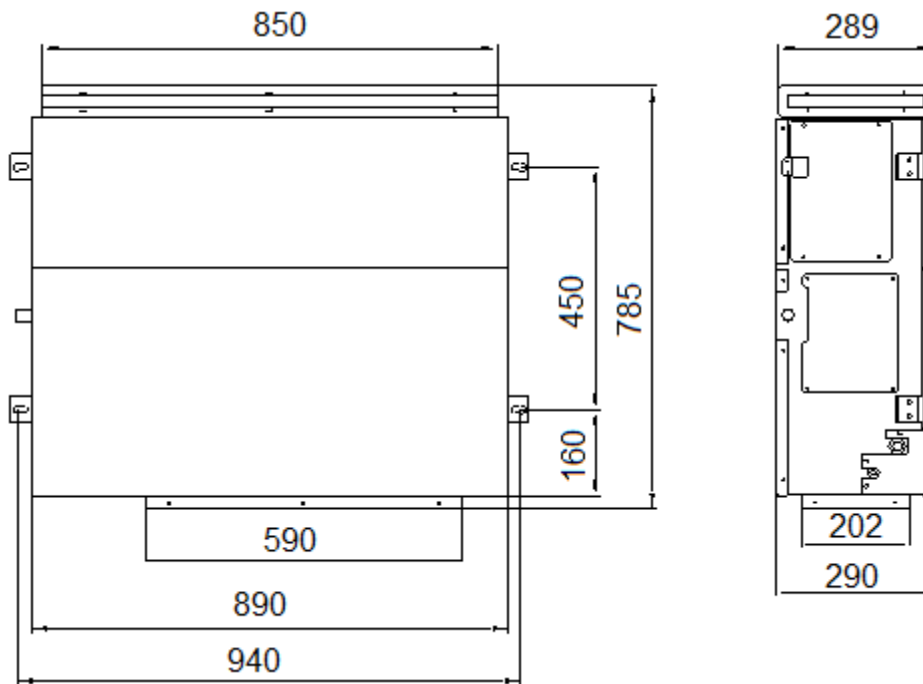

ALMD-H48/5R1D, ALMD-H60/5R1D

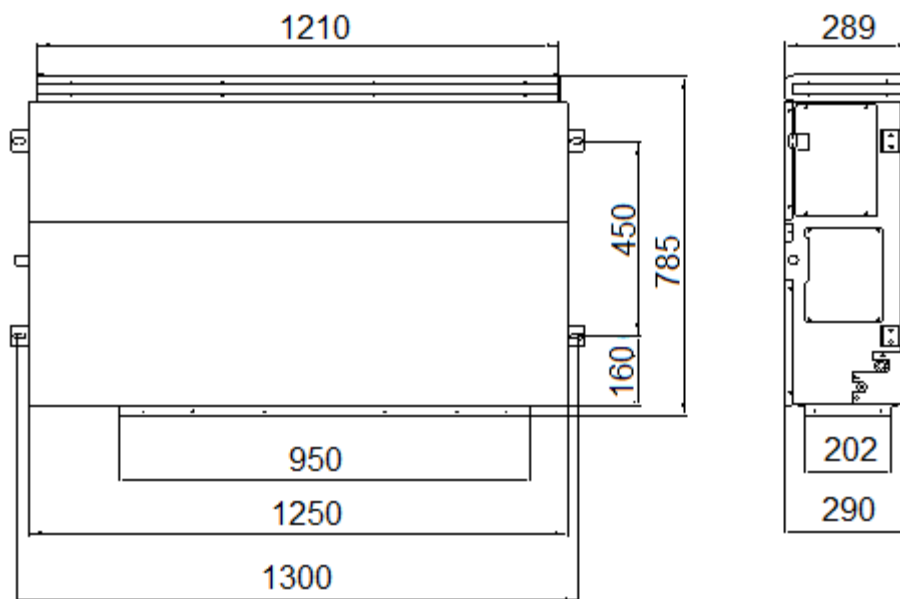

5. Electrical wiring and connection

ALMD-H18/4R1D,

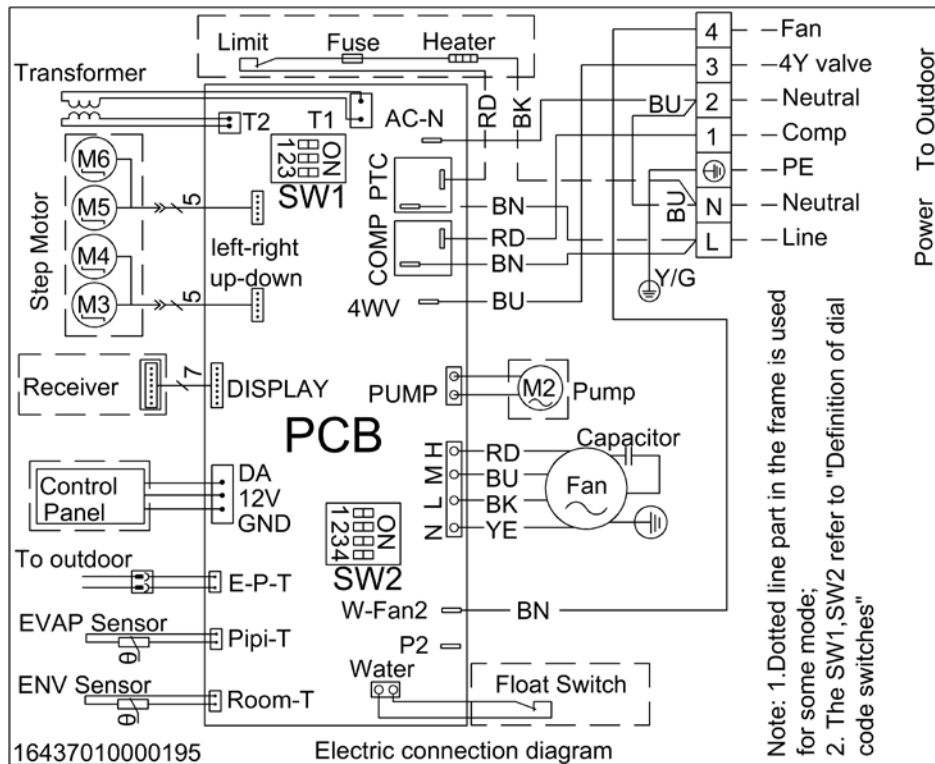

ALMD-H24/4R1D

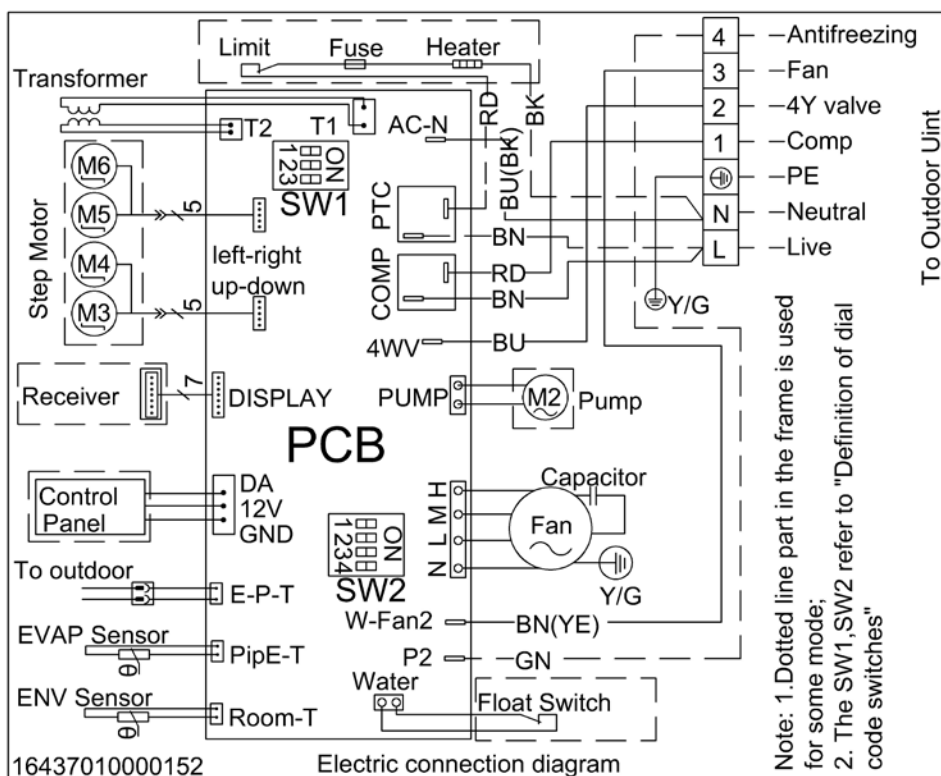

ALMD-H36/5R1D, ALMD-H48/5R1D, ALMD-H60/5R1D

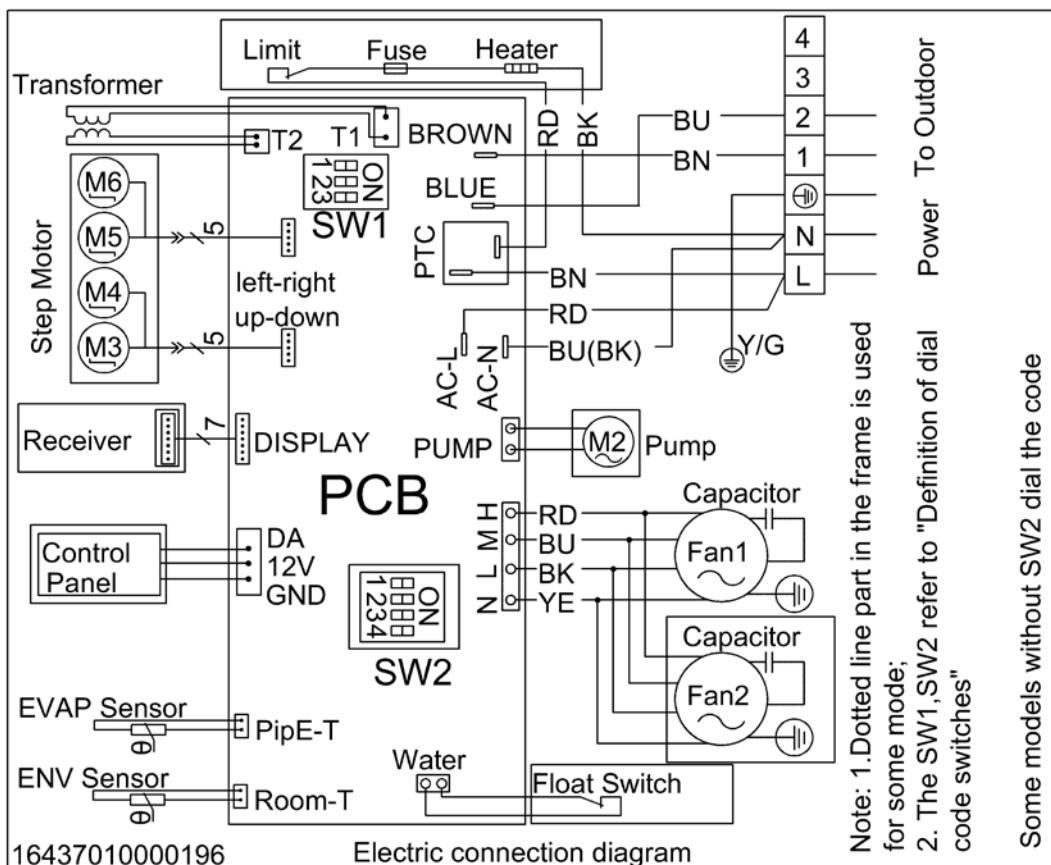

ALMD-H18/4R1D

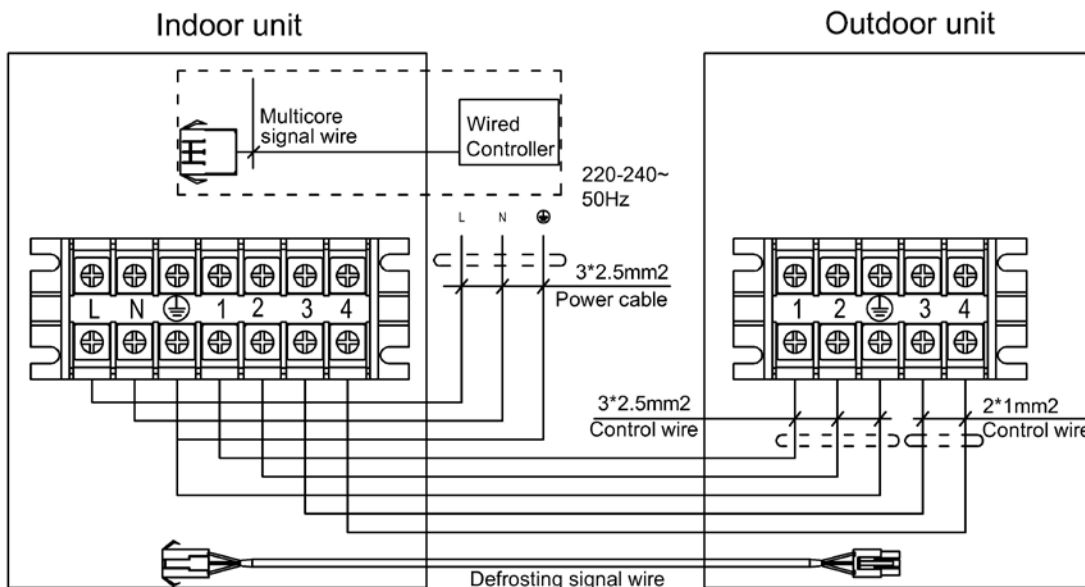

ALMD-H24/4R1D

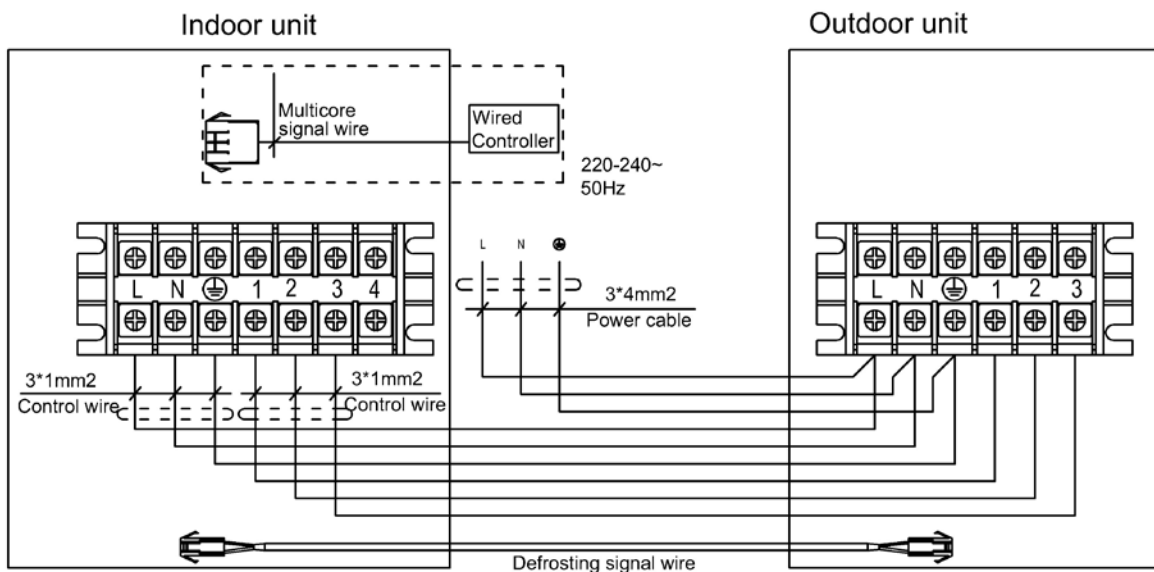

ALMD-H36/4R1

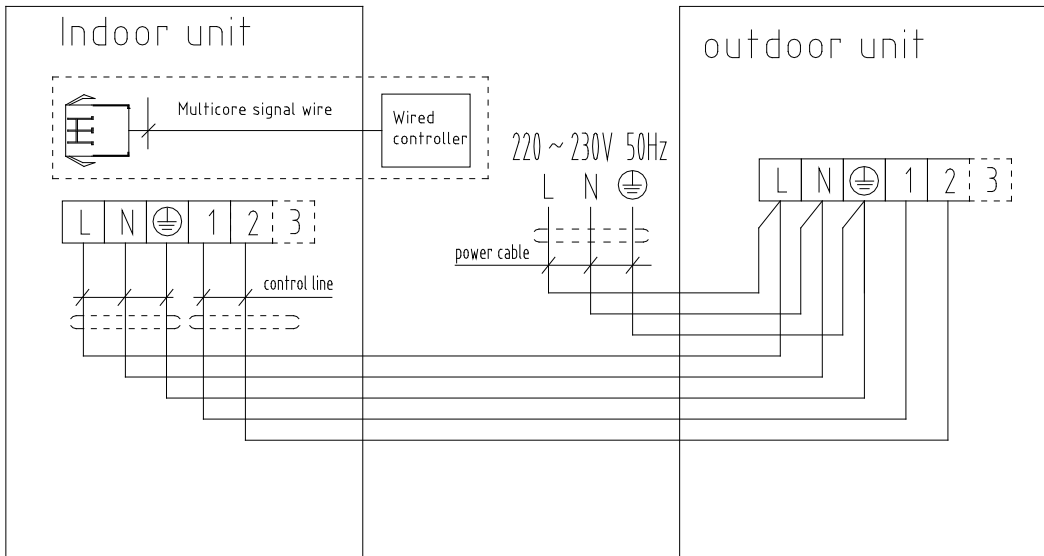

ALCA-H36/5R1D, ALCA-H48/5R1D, ALCA-H60/5R1D

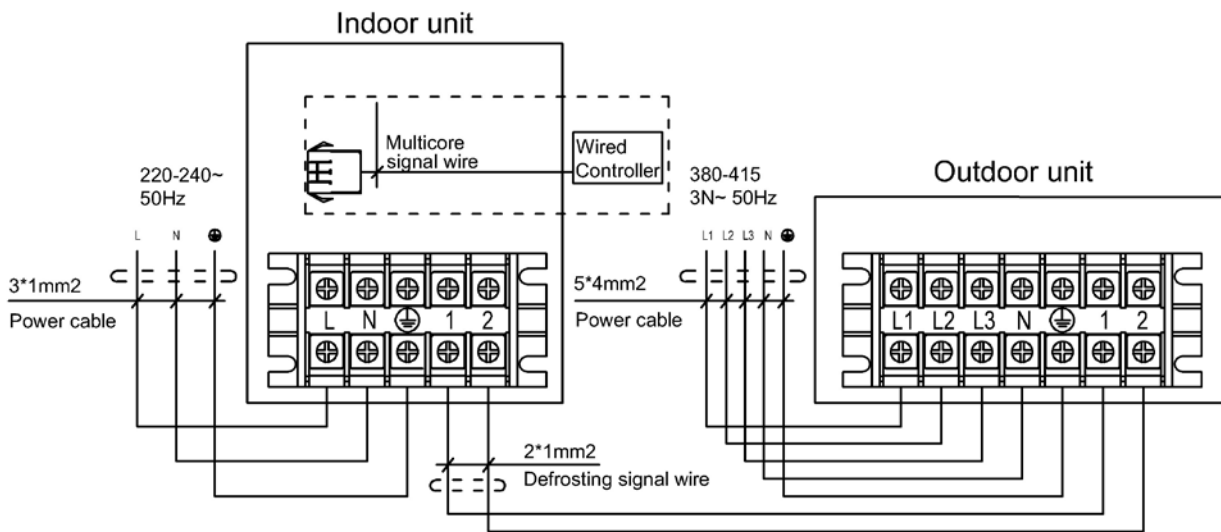

Introduction of Control Board QRDL-3F(2S)-SYE1 (indoor unit) (match with the outdoor unit which the Power supply is 220V-240V, 1PH)

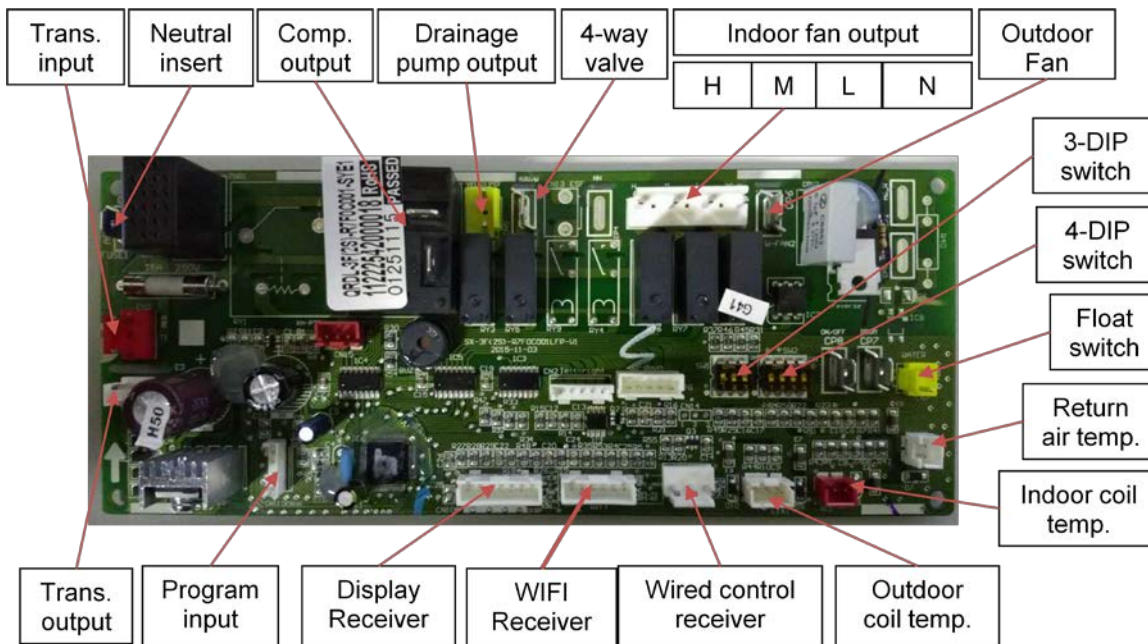

Introduction of control board QRD-SN3F(EX)-SYE1 sockets (Indoor unit) (match with the outdoor unit which the Power supply is 380V-415V, 3PH)

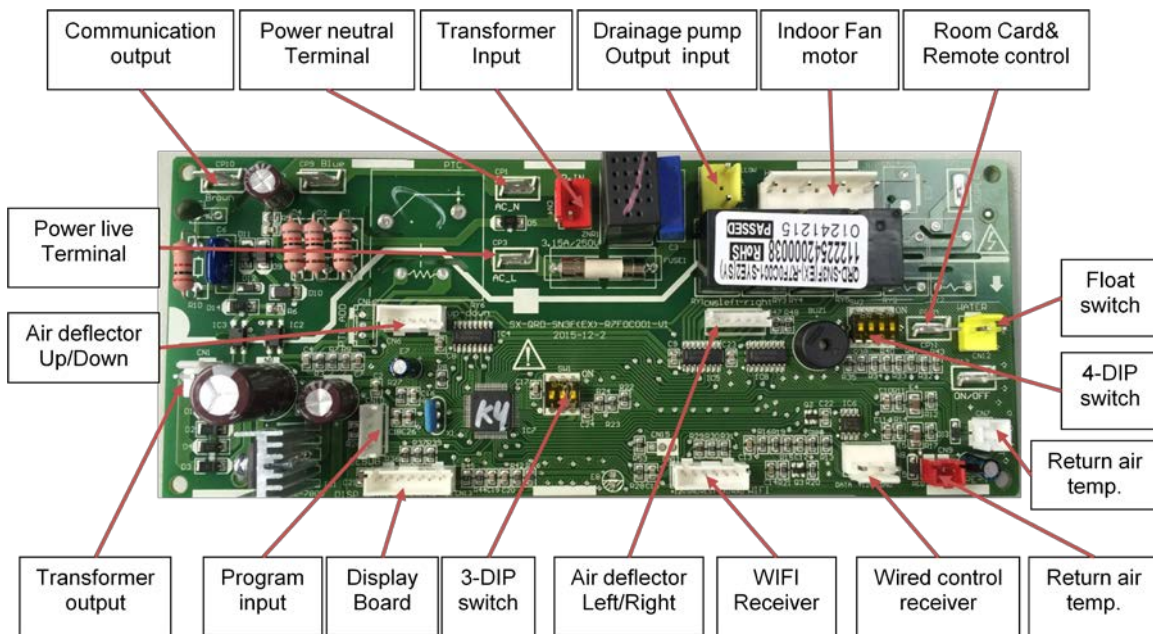

6.Fan performance

ALMD-H18/4R1D

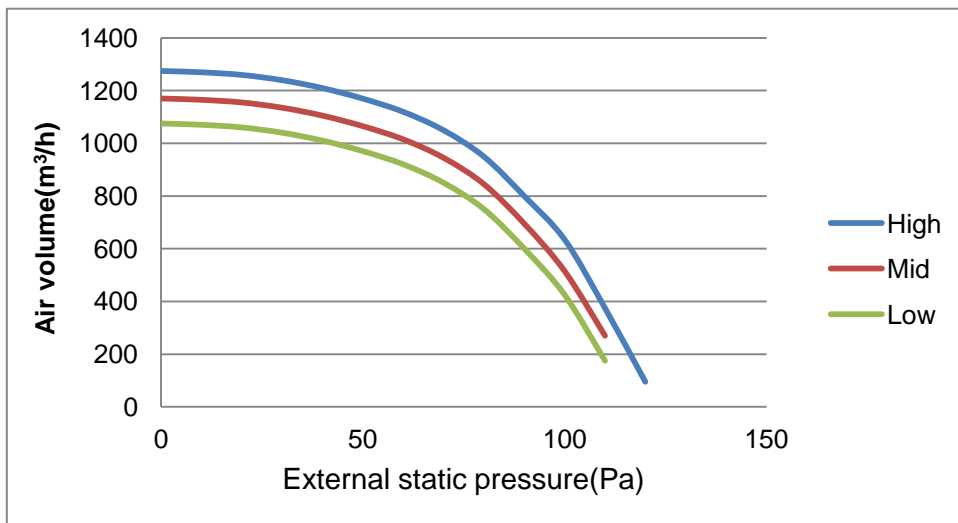

ALMD-H24/4R1D

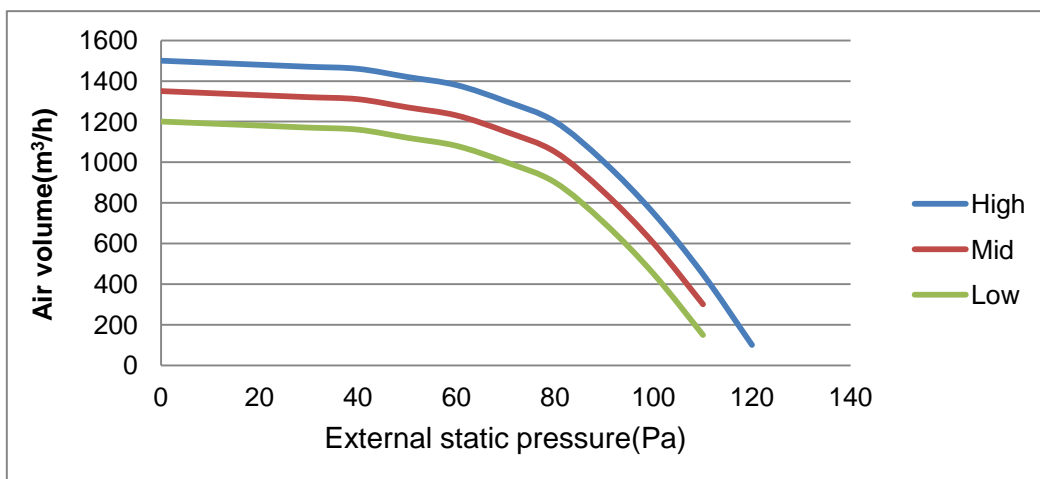

ALMD-H36/4R1,ALMD-H36/5R1D

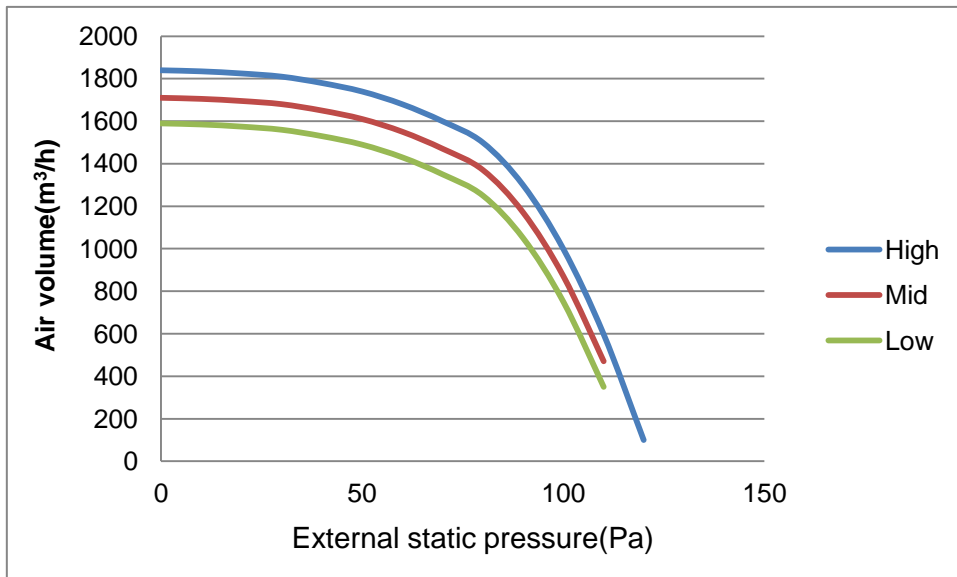

ALMD-H48/5R1D, ALMD-H60/5R1D

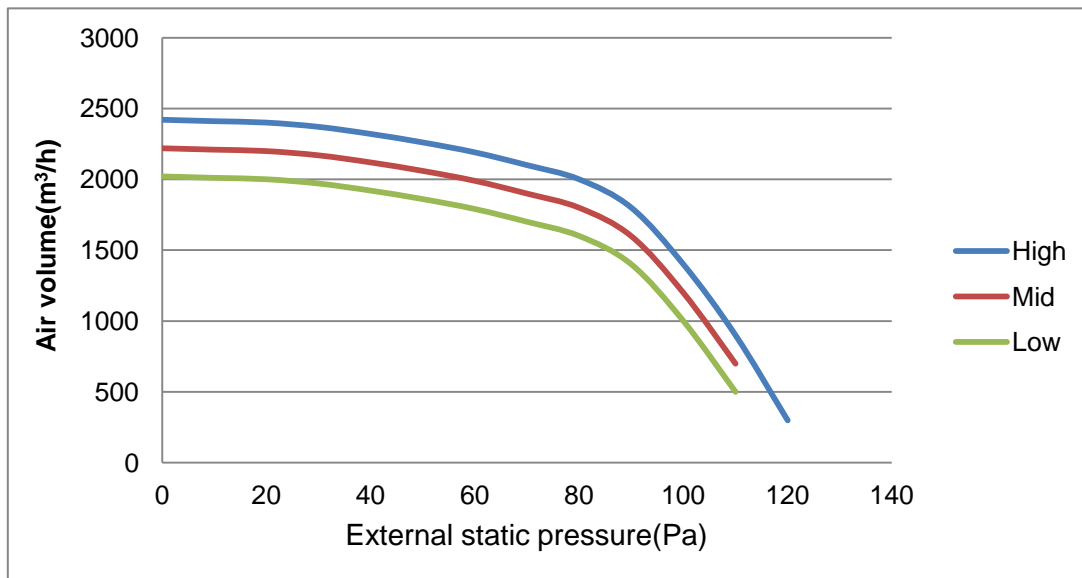

7. Installation

7.1 Preparation and equipments before installation

Please buy following spare parts from your local market before installation	Besides general implements, other implements are needed when connecting the pipe
Hung bolts M12, 4 pcs	Acetylene cylinders, oxygen cylinders (when longer pipe used it should be welded)
Drainage pipe PVC	One set pipe cut machine. (cut copper pipe)
Copper connecting pipe	Refrigerant cans, electronic balance (when longer pipe used additional gas should be charged)
Adhesive belt (big size) 5 pcs, (small size) 5 pcs	Pressure gauges, pipe clamp, welding torch, 2B silver electrode
Heat insulation material used to connect copper pipe (PE foam material, its thickness is more than 8mm)	Wrench 2 pcs, one of them is with adjustable torque wrench (42N.m,65N.m,100N.mm)
Power cable, electrical wire between indoor and outdoor unit(Must be in accordance with the wire diameter in the wiring diagram)	Nitrogen cylinder (in order to prevent oxidation when welding, using Nitrogen to replace the air)

7.2 Indoor unit installationprecaution

- ◇ Hanging location should be able to support the unit's weight, there should be no increase in noise and vibration. If the hanging location needs reinforcement, it should be reinforced before installation;
- ◇ Choose the space above the ceiling that can put the indoor unit inside;
- ◇ The location should be easy for drainage;
- ◇ The unit should not be installed in the heat source, steam source oil mist places (such as machine room, kitchen, laundry room, mechanical workshop, etc.) in order to avoid performance degradation, electric shock, plastic parts corrosion which lead to unit broken;
- ◇ Choose the location at least 1 meter away from TV and radio, in order to avoid interference to them
- ◇ There is no obstacles getting in the way of air circulation, cold air can evenly spread to all corners of the room;
- ◇ In order to facilitate maintenance and repair, there should be certain distance between indoor unit and obstacles;
- ◇ Refrigerant R22 is used for this unit, which is non-flammable and non-toxic gas. As the proportion of refrigerant is bigger than air, so if it leaks the gas will be filled on the ground. Therefore, if the units mounted on a closed room there must be good ventilation to prevent suffocation. In case of leakage of refrigerant, units should immediately stop running, and contact with maintenance personnel in time. There must be no fire at the site, because the refrigerant will turn to harmful gas when get to the fire.

7.3 The distance between indoor unit and obstacle

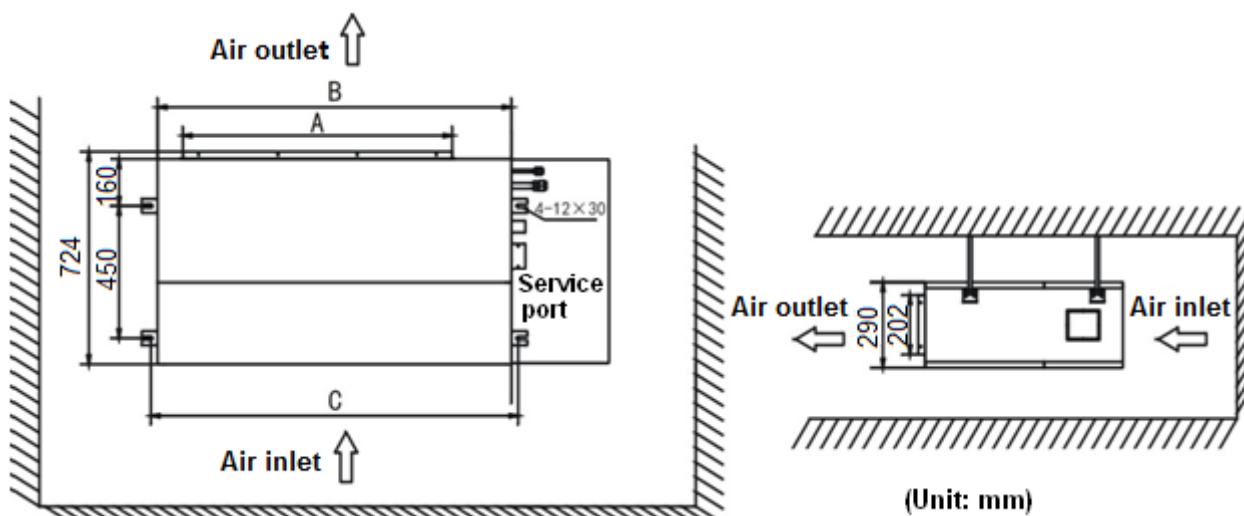

7.4 Indoor unit suspension

- ◇ Select the suspension foundation
The suspension foundation is a structure of either wooden frame or reinforced concrete. It must be firm and reliable to bear at least 4 times the weight of itself and capable of bearing vibration for long periods;

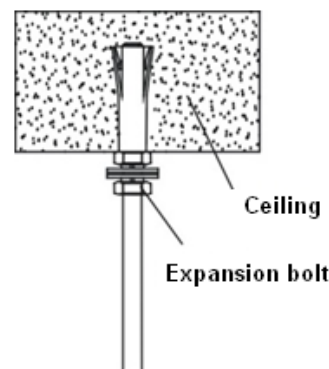

Fixing of suspension foundation

- Fix the suspension bolts either as shown in the picture or by a steel or wooden bracket;
- ◇ Adjust the relative positions of the suspension hooks to ensure the indoor unit is level in all directions. Use a spirit level to ensure this, otherwise water leakage, air leakage etc. will be resulted;
- ◇ Tighten the nuts and ensure that the hooks are tightly connected to the nuts and shims, and there is no phenomenon of virtual hanging;
- ◇ After the unit is installed ensure it is secure and does not shake or sway.

7.5 Duct pipeline installation

Using canvas to connect between indoor unit and duct pipeline, in order to save unnecessary vibration, as to the detail connection method please refer to the following picture.

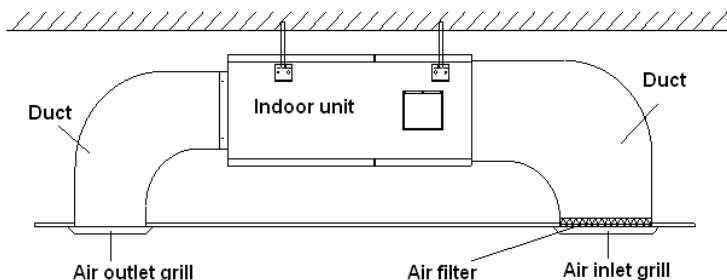

7.6 Drainage pipe

- ◇ Drainage pipes must be wrapped with heat insulation materials, otherwise it will cause frost or droplets, see picture as follows:

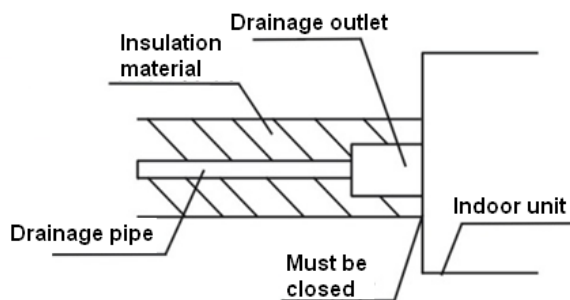

Heat insulation material: rubber insulation pipe with the thickness of more than 8mm

- ◇ Drainage pipe must have a downward gradient (1 / 50 1 / 100). If the drain pipe is installed ups and downs, it will cause water backflow or leakage etc.

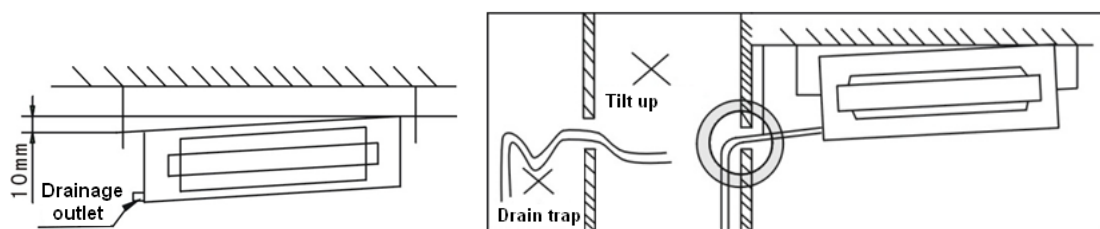

- ◇ When finish installation please carry out the drainage test to ensure that the water flow through the pipeline fluently, and carefully observe the junction to ensure that there is no water leakage at the junction. If the unit is installed in the newly built house, strongly recommend that this test taken before the CFiling installation. Even it is the heating only unit, this test is unavoidable.

7.7 Remote controller receiver

- ◇ **Installation site:** recommend that the receiver is mounted with the distance of 30~50 cm to the indoor unit air outlet(on your choice as well), while must ensure that the receiver can get the signal that the remote controller sends, please refer to the following installation picture:
- ◇ Mounting hole set up: please use certain instrument to dig a square hole with 88*88mm on the ceiling
- ◇ Remote controller receiver installation.
Hold the two sides (with clip sides) of the receiver, set the spring clip in the vertical way then put it into the mounting hole, if the two sides of the receiver is in the same level with the ceiling the installation is finished.
- ◇ Signal line connection: connect the wire of remote controller receiver to the CN-DISP terminal board on PCB of indoor unit wire box then fix it.

8.Explode view

ALMD-H18/4R1D ALMD-H24/4R1D ALMD-H36/4R1 ALMD-H36/5R1D

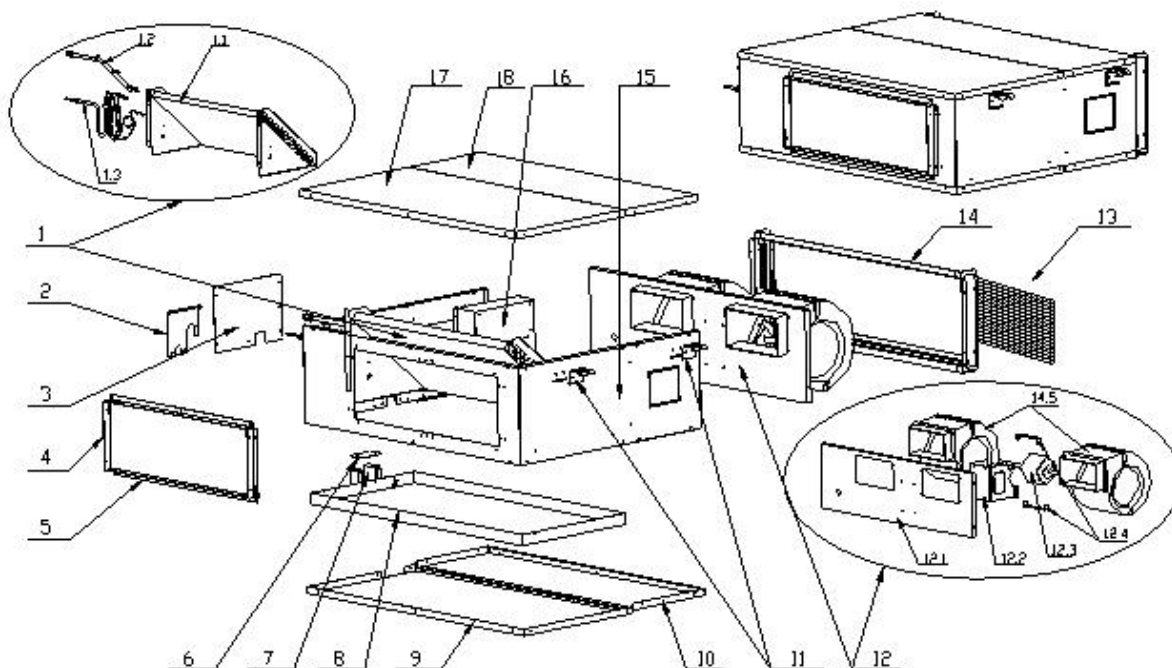

ALMD-H18/4R1D, ALMD-H24/4R1D, ALMD-H36/4R1, ALMD-H36/5R1D

NO.	Chinese name	Part Name	Quantity
1	蒸发器总成	Evaporator Assembly	1
1.1	蒸发器组件	Evaporator assembly	1
1.2	蒸发器出气管组件	Evaporator out pipe assembly	1
1.3	蒸发器进液管组件	Evaporator in pipe assembly	1
2	阀板	Valve board	1
3	电控盒盖	Electronics Box cover	1
4	出风法兰 A	Air outlet flange A	2
5	出风法兰 B	Air outlet flange B	2
6	排水管保护板 B	Drain pipe bracket B	1
7	排水管保护板 A	Drain pipe bracket A	1
8	凝水盘组件	Drain pan assembly	1
9	底板	Chassis	1
10	回风盖板 A	Air inlet cover board A	1
11	吊钩	Hanger	4
12	蜗壳固定板组件	Centrifugal fan bracket assembly	1
12.1	蜗壳固定板	Centrifugal fan bracket	1
12.2	电机架组件	Motor bracket assembly	1
12.3	室内电机 YSK100	Fan motor YSK100	1
12.4	电机抱攀	Fan motor Clamp	2
12.5	离心风机	Centrifugal fan	2

13	空气过滤网	Air filter	1
14	过滤网滑道组件	slideway assembly	1
14.1	左右滑道组件	Left&Right slideway assembly	2
14.2	上下滑道组件	Up&down slideway assembly	2
14.3	左右过滤器法兰	Left&Right france	2
14.4	上下过滤器法兰	Up&down france	2
15	围板	Cabinet	1
16	电控盒总成	Electronics Box assembly	1
16.1	控制板	PCB board	1
16.2	变压器 QC2-E1	Transformer	1
16.3	回风温度传感器	Sensor 5K3470 1	1
16.4	盘管温度传感器	Sensor 5K3470 2	1
16.5	端子板 7 位	Terminal board	1
16.6	电控盒组件	Electric components box	1
17	顶盖板	Top cover board	1
18	回风盖板 B	Air inlet cover board B	1

ALMD-H48/5R1D, ALMD-H60/5R1D

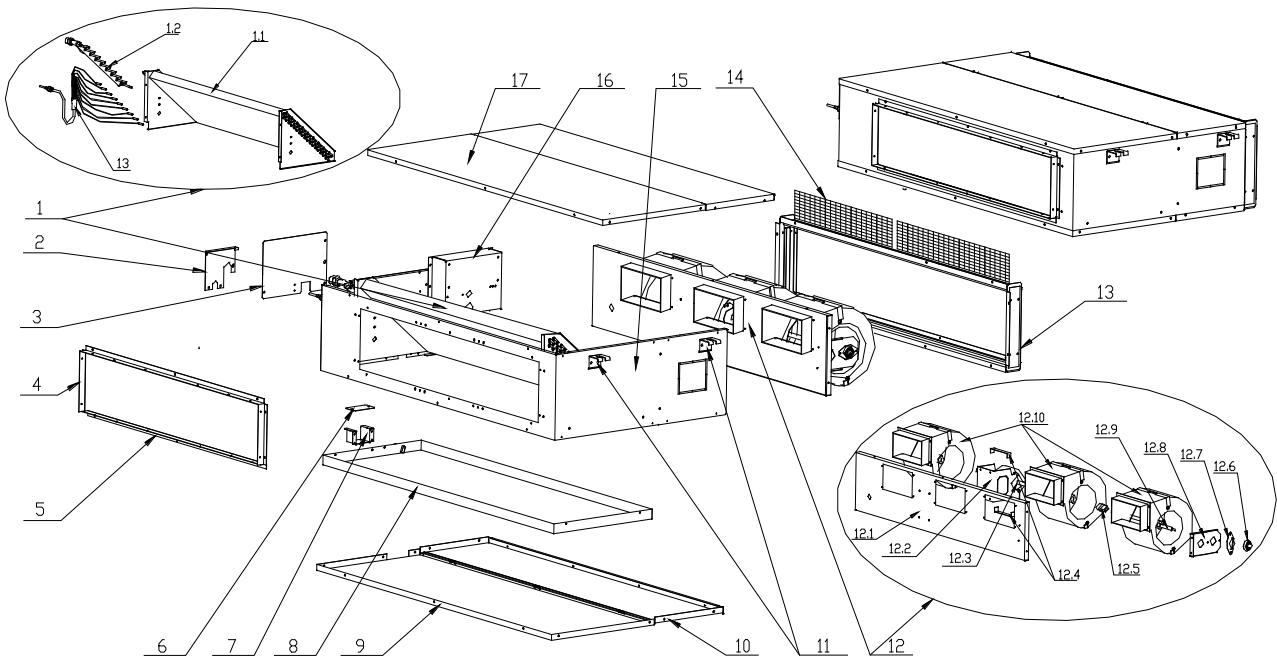

ALMD-H48/5R1D, ALMD-H60/5R1D

NO.	Chinese name	Part Name	Quantity
1	蒸发器总成	Evaporator Assembly	1
1.1	蒸发器组件	Evaporator assembly	1
1.2	蒸发器集气管组件	Evaporator out pipe assembly	1
1.3	蒸发器进液管组件	Evaporator in pipe assembly	1
2	阀板	Valve board	1

3	电控盒盖	Electronics Box cover	1
4	出风法兰 A	Air outlet flange A	2
5	出风法兰 B	Air outlet flange B	2
6	排水管保护板 B	Drain pipe bracket B	1
7	排水管保护板 A	Drain pipe bracket A	1
8	凝水盘组件	Drain pan assembly	1
9	底板	Chassis	1
10	回风盖板 A	Air inlet cover board A	1
11	吊钩	Hanger	4
12	蜗壳固定板组件	Centrifugal fan bracket assembly	1
12.1	蜗壳固定板	Centrifugal fan bracket	1
12.2	电机架组件	Motor bracket assembly	1
12.3	室内风扇电机 YSK-180	Fan motor YSK-180	1
12.4	电机抱攀	Fan motor clamp	2
12.5	联轴器 $\Phi 14$	Coupling	1
12.6	橡胶轴承	Rubber axletree	1
12.7	橡胶轴承压板	Rubber axletree board	1
12.8	橡胶轴承支架	Rubber axletree bracket	1
12.9	加长轴 $\phi 14 \times 470$	Axes $\phi 14 \times 470$	1
12.1	离心风机	Centrifugal fan assembly	3
13	过滤网滑道组件	slideway assembly	1
13.1	左右滑道组件	Left&Right slideway assembly	2
13.2	上下滑道组件	Up&down slideway assembly	2
13.3	左右过滤器法兰	Left&Right france	2
13.4	上下过滤器法兰	Up&down france	2
14	空气过滤器	Air filter	2
15	围板	Boarding	1
16	电控盒总成	Electronics Box assembly	1
16.1	控制板	PCB board	1
16.2	变压器 QC2-E1	Transformer	1
16.3	回风温度传感器	Sensor 5K3470 1	1
16.4	盘管温度传感器	Sensor 5K3470 2	1
16.5	端子板 5 位	Terminal board	1
16.6	电控盒组件	Electric components box	1
17	顶盖板	Top cover board	1
18	回风盖板 B	Air inlet cover board B	1

Part 3 Universal outdoor unit

1.Specfication	81
2.Capacity Amendment.....	86
3.Dimension	88
4.System principle diagram.....	90
5.Electrical wiring and connection	92
6.Explore View	95
7.Installation	100

1. Specification

Model			AL-H12/4R1D(U)	AL-H18/4R1D(U)	AL-H24/4R1D(U)
Factory Model			AL-H12A4/R1(T)-B 7	AL-H18A4/R1(T)-B7	AL-H24A4/R1(T)-B7
Code			16107022000017	16107022000019	16107022000018
Power Supply		V~,Hz ,Ph	220~240,50,1	220~240,50,1	220~240,50,1
Max. Input Consumption		W	1750	2700	3200
Max. Current		A	7.76	12.10	17.80
Capacity	Cooling	Btu/h	12000	18000	24000
		kW	3.52	5.28	7.20
	Heating	Btu/h	13500	20000	27569
		kW	3.90	5.80	8.08
Compressor	Model		ASL150UV-C7LU	ASL201UV-C7EQ	ASH286UV-C8DU
	Type		Rotary	Rotary	Rotary
	Brand		HIGHLY	HIGHLY	HIGHLY
	Capacity	W	3555	4900	6980
	Input	W	1200	1633	2320
	Rated Current(RLA)	A	5.55	7.65	10.9
	Locked Rotor Amp(LRA)	A	30	38	60
	Thermal Protection temp.		150	150	160
	Capacitor	uF	35	50	70
	Refrigerant Oil	ml	450	480	570
Outdoor Fan Motor	Model		YDK31-6F	YDK31-6F	YDK68-6A
	Brand		Tongdeli	Tongdeli	Sinjun
	Output Power x Fan quantity	W	31×1	31×1	68×1
	Capacitor	uF	2.5	2.5	4
	Speed	r/min	900	900	880
Coil	Number Of Row		1	2	2
	Tube Pitch(a)x Row Pitch(b)	mm	22×19.05	22×19.05	22×19.05
	Fin Pitch	mm	1.4	1.4	1.5
	Fin Material		Hydrophilic aluminum fin		
	Tube Outside Dia.and Material	mm	φ7 , Inner grooved	φ7 , Inner grooved	φ7 , Inner grooved
	Coil Length x Height x Width	mm	853×506×19.05	853×506×38.1	763×616×38.1
	Heat Exchanging Area	m ²	10.47	15.99	22.10
Air Flow Volume		CFM	1471	1471	1648
			m ³ /h	2500	2500
Noise Level		dB(A)	53	55	60
Dimension (WxDxH)	Net	mm	800×286×530	800×286×530	822×302×655
	Packing	mm	920×400×620	920×400×620	945×430×725
Weight	Net	kg	37	40	50
	Gross	kg	40	43	54
Refrigerant	Type		R410A	R410A	R410A

Type/Quantity	Charged Volume	g	800	1250	1400
Design Pressure		MPa	4.4	4.4	4.4
Refrigerant Piping	Liquid Side	mm	6.35	6.35	9.52
	Gas Side	mm	12.7	12.7	15.88
	Max. Length	m	15	20	30
	Max. Height	m	10	15	15
Operation Temperature Range		°C	16~32	16~32	16~32
Ambient Temperature Range(Cooling/Heating)		°C	-15~49/-15~24	-15~49/-15~24	-15~49/-15~24
Application Area		m ²	13-21	21-35	28-47
Connection Wiring	Power Wiring(Indoor)	mm ²	3×2.5mm ²	3×2.5mm ²	/
	Power Wiring(Outdoor)	mm ²	/	/	3×6mm ²
	Signal Wiring	mm ²	3×2.5mm ² +2×1mm ₂	3×2.5mm ² +2×1mm ²	3×2.5mm ² +3×1mm ²
Stuffing Quantity	20/40/40H	Unit	102/219/292	102/219/292	96/198/198

Notes:

1. Nominal cooling capacities are based on the following conditions: Return air temp.: 27°CDB, 19°CWB, and outdoor temp.: 35°CDB, 24°CWB;
2. Nominal heating capacities are based on the following conditions: Return air temp.: 20°CDB, and outdoor temp.: 7°CDB, 6°CWB;
3. Parameters above are all measured when the connecting pipe is 5 meters.

Model			AL-H36/5R1D(U)	AL-H48/5R1D(U)	AL-H60/5R1D(U)
Factory Model			AL-H36A5/R1(T)-B7	AL-H48A5/R1(T)-B7	AL-H60A5/R1(T)-B7
Code			16107022000020	16107022000022	16107022000023
Power Supply		V~,Hz ,Ph	380~415,50,3	380~415,50,3	380~415,50,3
Max. Input Consumption		W	5100	5950	7800
Max. Current		A	9.50	13.50	16.50
Capacity	Cooling	Btu/h	36000	48000	60000
		kW	10.55	14.07	17.58
	Heating	Btu/h	40000	53000	63500
		kW	11.70	15.50	18.50
Compressor	Model		ATH420UC-C9EU	ATE498SC3Q9RK1	ATE590SC3Q9JK
	Type		Twin Rotary	Twin Rotary	Twin Rotary
	Brand		HIGHLY	HIGHLY	HIGHLY
	Capacity	W	10150	12650	14850
	Input	W	3350	4130	4950
	Rated Current(RLA)	A	6.9	7.2	8.7
	Locked Rotor Amp(LRA)	A	66	69	65
	Thermal Protection temp.		180	160	180
	Capacitor	uF	/	/	/
	Refrigerant Oil	ml	840	1600	1850
Outdoor Fan Motor	Model		YDK150-6C-420	YDK60-6H	YDK60-6H
	code		/	/	/
	Brand		Weiling	Sinjun/Welling	Sinjun/Welling
	Output Power x Fan quantity	W	150x1	60x2	60x2
	Capacitor	uF	6	3.5x2	3.5x2
	Speed	r/min	820	750	750
Coil	Number Of Row		2	1.5	1.5
	Tube Pitch(a)x Row Pitch(b)	mm	22x19.05	22x19.05	22x19.05
	Fin Pitch	mm	1.4	1.4	1.4
	Fin Material		Hydrophilic aluminum fin		
	Tube Outside Dia.and Material	mm	φ7 , Inner grooved	φ7 , Inner grooved	φ7 , Inner grooved
	Coil Length x Height x Width	mm	894x814x38.1	973x1320x38.1	973x1320x38.1
	Heat Exchanging Area	m2	35.30	47.62	47.62
Air Flow Volume		CFM	1876	3765	3765
			m ³ /h	3190	6400
Noise Level		dB(A)	62	60	60
Dimension (WxDxH)	Net	mm	903x354x857	940x368x1366	940x368x1366
	Packing	mm	1030x410x980	1080x460x1500	1080x460x1500
Weight	Net	kg	71	101	102
	Gross	kg	81	112	113
Refrigerant Type/Quantity	Type		R410A	R410A	R410A
	Charged Volume	g	2150	2750	2900

Design Pressure		MPa	4.4	4.4	4.4
Refrigerant Piping	Liquid Side	mm	9.52	9.52	9.52
	Gas Side	mm	15.88	19.05	19.05
	Max. Length	m	50	50	50
	Max. Height	m	30	30	30
Operation Temperature Range		°C	16~32	16~32	16~32
Ambient Temperature Range(Cooling/Heating)		°C	-15~49/-15~24	-15~49/-15~24	-15~49/-15~24
Application Area		m ²	42-70	56-93	64-107
Connection Wiring	Power Wiring(Indoor)	mm ²	3×1mm ²	3×1mm ²	3×1mm ²
	Power Wiring(Outdoor)	mm ²	5×4mm ²	5×4mm ²	5×4mm ²
	Signal Wiring	mm ²	2×1mm ²	2×1mm ²	2×1mm ²
Stuffing Quantity	20/40/40H	Unit	60/126/126	27/55/55	27/55/55

Notes:

1. Nominal cooling capacities are based on the following conditions: Return air temp.: 27°CDB, 19°CWB, and outdoor temp.: 35°CDB, 24°CWB;
2. Nominal heating capacities are based on the following conditions: Return air temp.: 20°CDB, and outdoor temp.: 7°CDB, 6°CWB;
3. Parameters above are all measured when the connecting pipe is 5 meters.

4.

Model		AL-H36/4R1(U)	
Factory Model		AL-H36A4/R1(T)	
Code		16107022000001	
Power Supply		V~,Hz,Ph	220~240,50,1
Max. Input Consumption		W	5200
Max. Current		A	17.8
Capacity	Cooling	Btu/h	36000
		kW	10.6
	Heating	Btu/h	37500
		kW	10.9
Compressor	Model	ATH420MV-C9EU	
	Type	rotary	
	Brand	HITACHI	
	Capacity	W	10200
	Input	W	3435
	Rated Current(RLA)	A	16.2
	Locked Rotor Amp(LRA)	A	/
	Thermal Protection temp.	/	
	Capacitor	uF	/
	Refrigerant Oil	ml	HAF68D1/840±20
OutdoorFan Motor	Model	YDK150-6C	
	Brand	HUATE	

	Output Power x Fan quantity	W	150×1
	Capacitor	uF	6
	Speed	r/min	820
Coil	a.Number Of Row		2
	b.Tube Pitch(a)x Row Pitch(b)	mm	22×19.05
	c.Fin Pitch	mm	1.4
	d.Fin Material		Hydrophilic aluminum fin
	e.Tube Outside Dia.And Material	mm	φ7.94 , Inner grooved
	f.Coil Length x Height x Width	mm	878×814×38.1
	g.Heat Exchanging Area	m ²	30.3
Air Flow Volume		CFM	1876
		m ³ /h	3190
Noise Level		dB(A)	60
Dimension(WxDxH)	Net	mm	903×354×857
	Packing	mm	1030×410×980
Weight	Net	kg	72
	Gross	kg	83
Refrigerant Type/Quantity	Type		R410A
	Charged Volume	g	2300
Design Pressure		MPa	4.4
Refrigerant Piping	Liquid Side	mm	9.52(3/8)
	Gas Side	mm	15.88(5/8)
	Max. Length	m	50
	Max. Height	m	30
Operation Temperature Range		°C	16~32
Ambient Temperature Range(Cooling/Heating)		°C	-5~49
Application Area		m ²	42-70
Connection Wiring	Power Wiring (Indoor)	mm ²	3×4mm ²
	Power Wiring (Outdoor)	mm ²	5×4mm ²
	Signal Wiring	mm ²	2×1mm ²
Stuffing Quantity	20/40/40H	Unit	35/72/82

Notes:

- Nominal cooling capacities are based on the following conditions: Return air temp.: 27°CDB, 19°CWB, and outdoor temp.: 35°CDB, 24°CWB;
- Nominal heating capacities are based on the following conditions: Return air temp.: 20°CDB, and outdoor temp.: 7°CDB, 6°CWB;
- Parameters above are all measured when the connecting pipe is 5 meters.

2. Capacity Amendment

2.1 Running range

Cooling capacity (Btu/h)	12000	18000	24000	36000	36000	48000	60000
Power supply	220-240V~/50Hz				380-415V 3N~/50Hz		
Voltage	187~242V				320~420V		
Ambient temperature	Cooling	-15~49°C					
	Heating	-15~24°C					

2.2 Amendment coefficient of cooling capacity under different indoor/outdoor DB and WB temperature

Indoor air inlet temperature°C		Outdoor air inlet DB temperature°C							
DB	WB	25	30	35	40	43	45	47	49
23	16	0.98	0.94	0.89	0.85	0.82	0.79	0.74	0.71
25	18	1.05	1	0.95	0.90	0.87	0.82	0.77	0.72
27	19	1.1	1.05	1	0.95	0.91	0.87	0.84	0.79
28	20	1.12	1.07	1.02	0.96	0.93	0.90	0.86	0.81
30	22	1.19	1.13	1.08	1.02	0.99	0.96	0.91	0.88
32	24	1.26	1.20	1.15	1.08	1.05	1.02	0.97	0.92

Actual cooling capacity calculation:

Actual cooling capacity=amendment coefficient of cooling capacity × nominal cooling capacity

——nominal cooling capacity could be found from the performance parameters list

——amendment coefficient of cooling capacity could be found from table above.

2.3 Amendment coefficient of heating capacity under different indoor/outdoor DB and WB temperature

Indoor air inlet DB temperature°C	Outdoor air inlet WB temperature°C						
	-15	-10	-5	0	6	10	15
16	0.45	0.53	0.65	0.80	1.02	1.13	-
18	0.47	0.55	0.61	0.76	1.02	1.12	-
20	0.46	0.54	0.6	0.75	1	1.11	1.25
21	0.42	0.49	0.59	0.72	0.99	1.1	1.24
22	0.41	0.49	0.58	0.71	0.97	1.09	1.23
24	0.39	0.45	0.56	0.7	0.96	1.08	1.22

Actual heating capacity calculation:

Actual heating capacity=amendment coefficient of heating capacity × nominal heating capacity

——nominal heating capacity could be found from the performance parameters list

——amendment coefficient of heating capacity could be found from table above.

2.4 Amendment coefficients of heating and cooling capacity under different height drop

Different Cooling Capacity modified coefficients at different height:

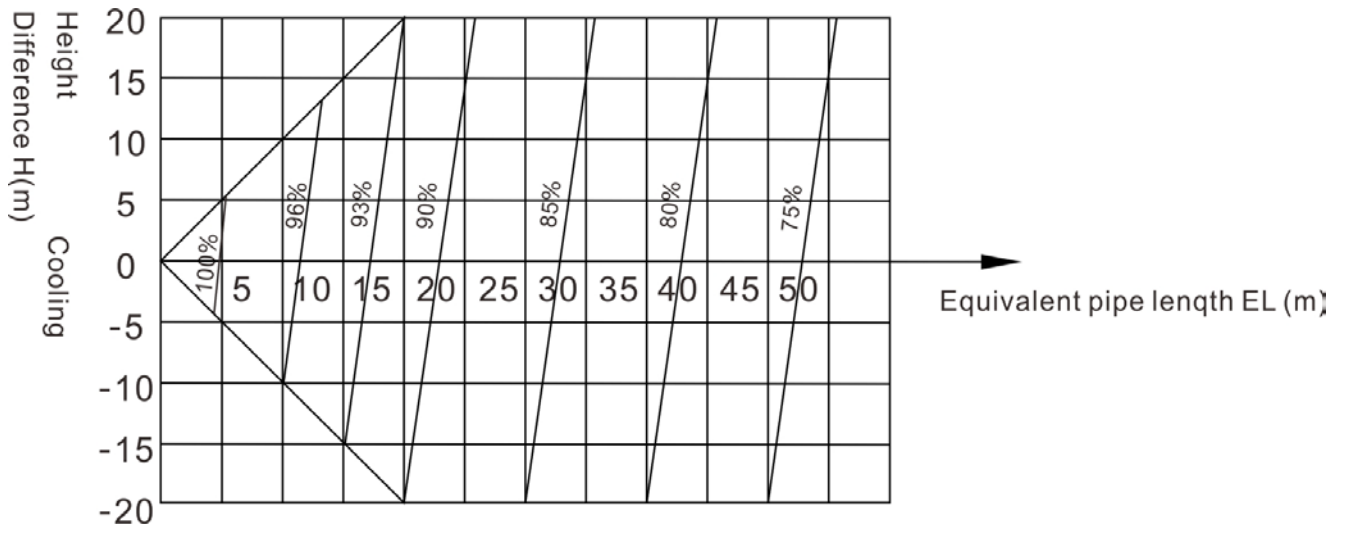

Note: H = Height of Outdoor Unit — Height of Indoor Unit

2.5 Different Heating Capacity modified coefficients at different height:

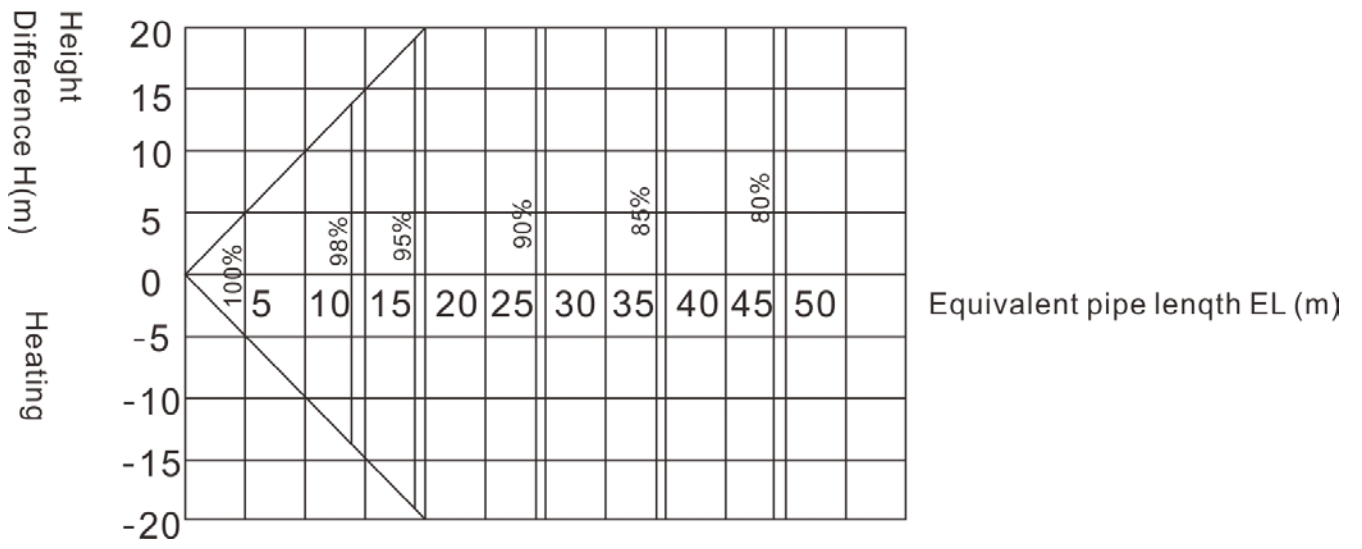

Note: H = Height of Outdoor Unit — Height of Indoor Unit

3. Dimension

AL-H12/4R1D(U) AL-H18/4R1D(U)

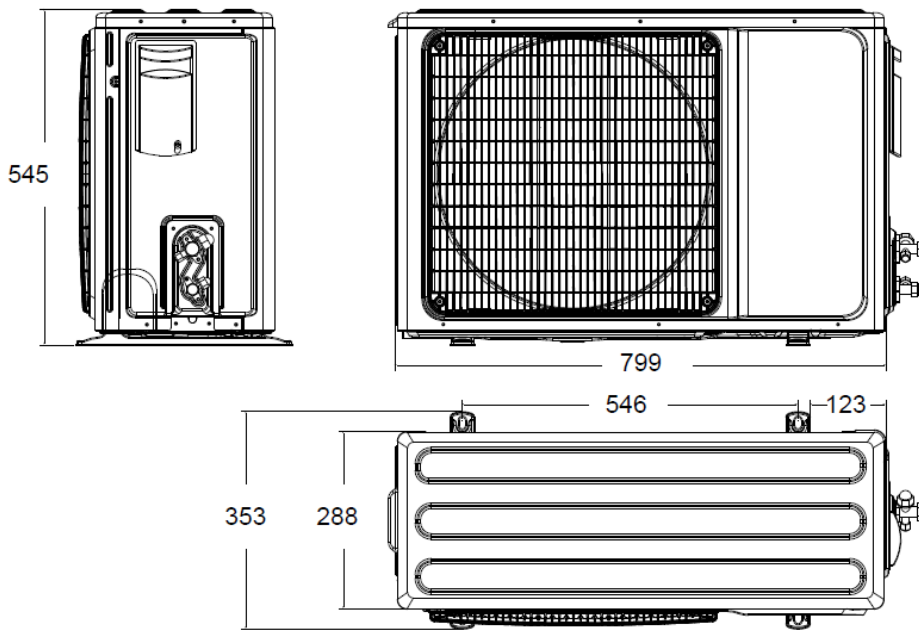

AL-H24/4R1D(U)

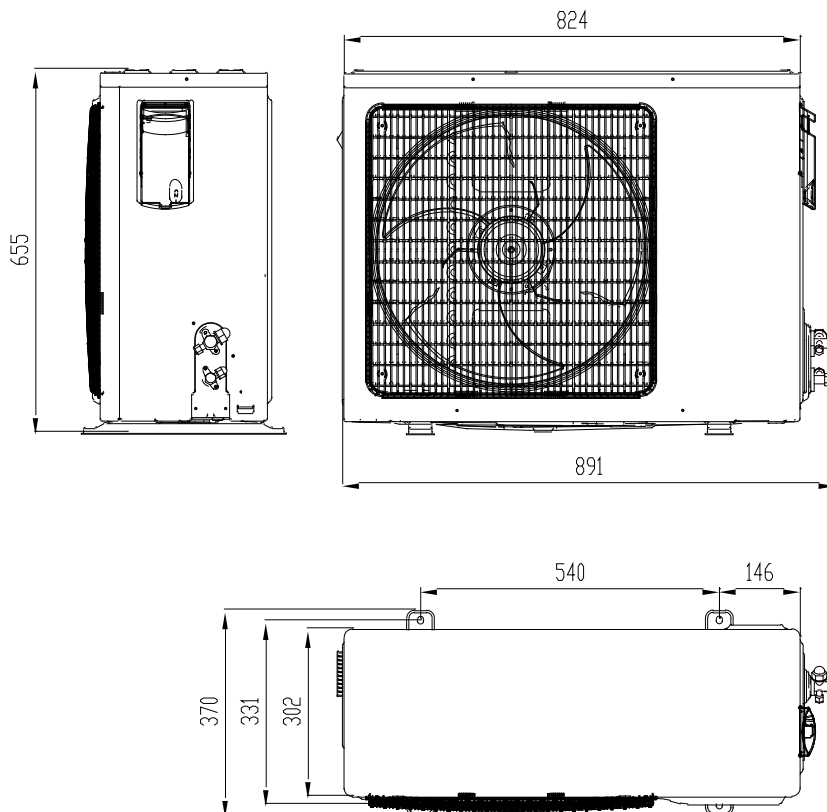

AL-H36/4R1(U),AL-H36/5R1D(U)

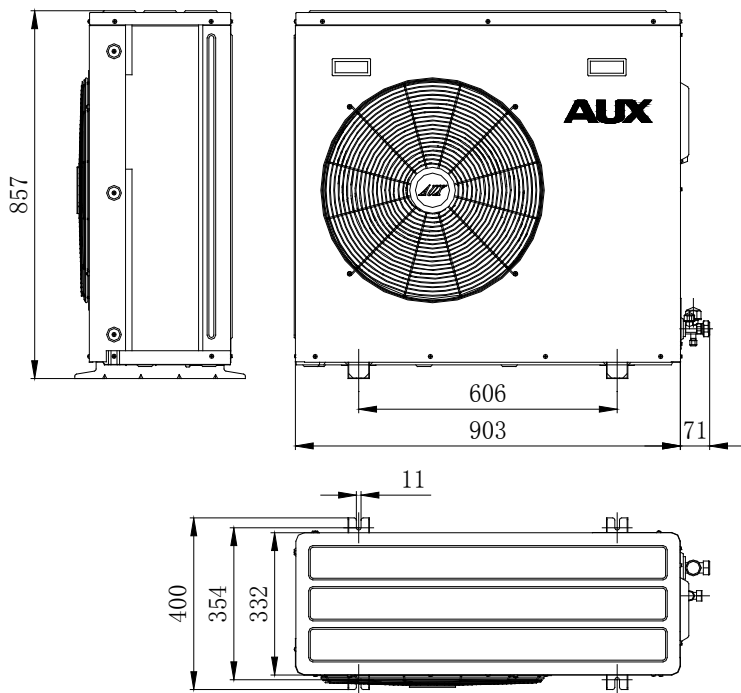

AL-H48/5R1D(U), AL-H60/5R1D(U)

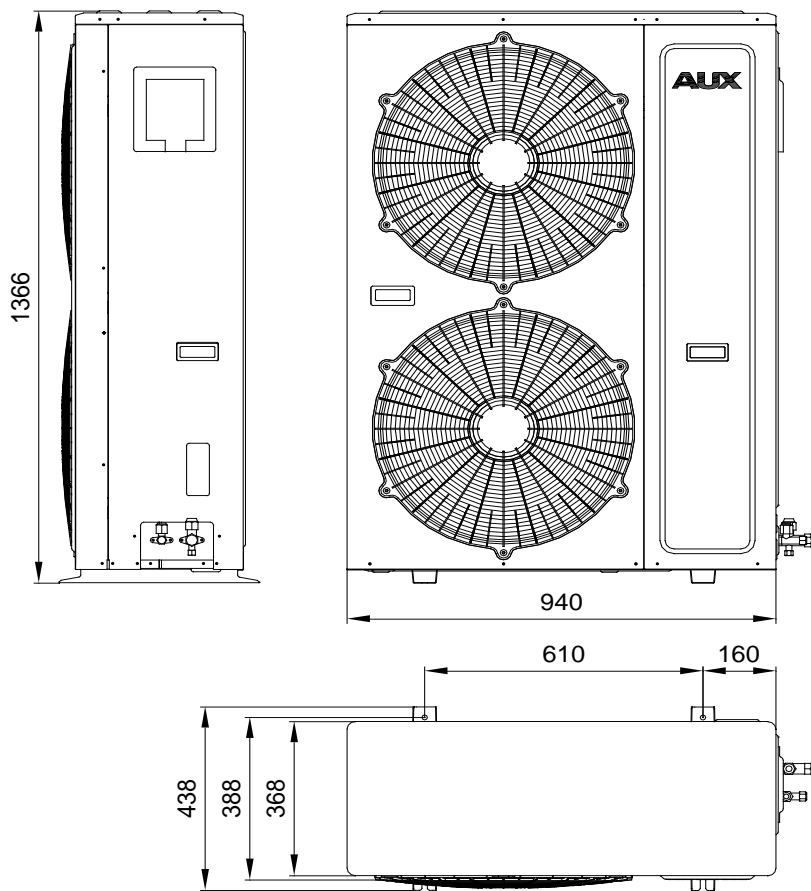

4. System principle diagram

Cooling circle:

the Compressor inhales the low-temperature and low-pressure refrigerant vapor from the evaporator, and vapor be turned into high-temperature and high-pressure gas then enters into condenser, the high-temperature and high-pressure refrigerant gas and outdoor air make heat exchange in the condenser, the compressed vapor is then cooled by heat exchange with the outside air, so that the vapor condenses to be a high-temperature and high-pressure fluid, and then through capillary throttling to cooled, low pressure, then the liquid enters into the evaporator and two-phase of gas and liquid refrigerant in the evaporator completely evaporate, thereby cooling the indoor air; from evaporator the vapor is inhaled into compressor again, so it runs continuously cycle to cycle, cooled air is continuous supplied to the air-conditioned area though Duct by fan motor.

Heating cycle:

It is the contrary cycle of cooling cycle, at this moment the 4-way valve changes direction, and make refrigerant flow to direction changer, that is, the vapor discharged from the compressor enters into the indoor heat exchanger to condense, the condensation of refrigerant after the capillary expenditure, evaporates in the outdoor heat exchanger, and then inhaled by the compressor after evaporation, so it runs continuously periodically , the heated air is continuous supplied to the air-conditioned area though duct by fan motor.

AL-H12/4R1D(U), AL-H18/4R1D(U)

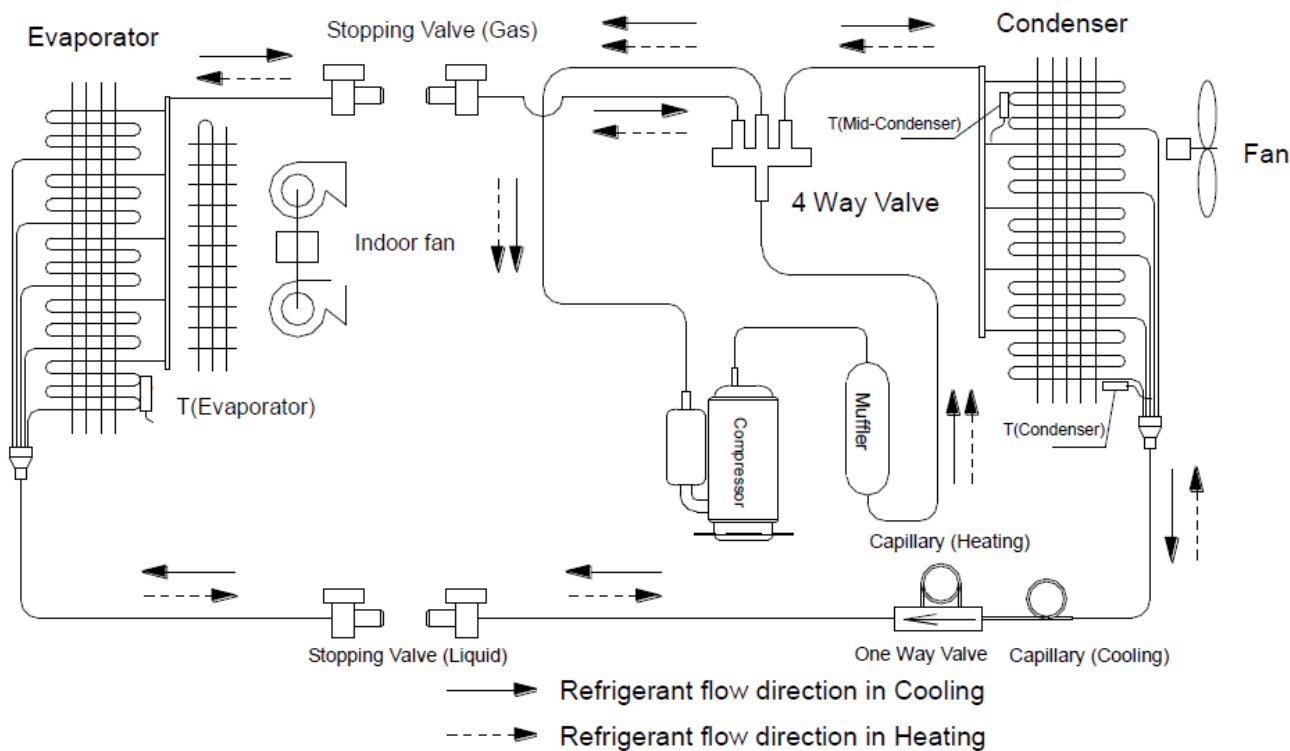

AL-H24/4R1D(U)

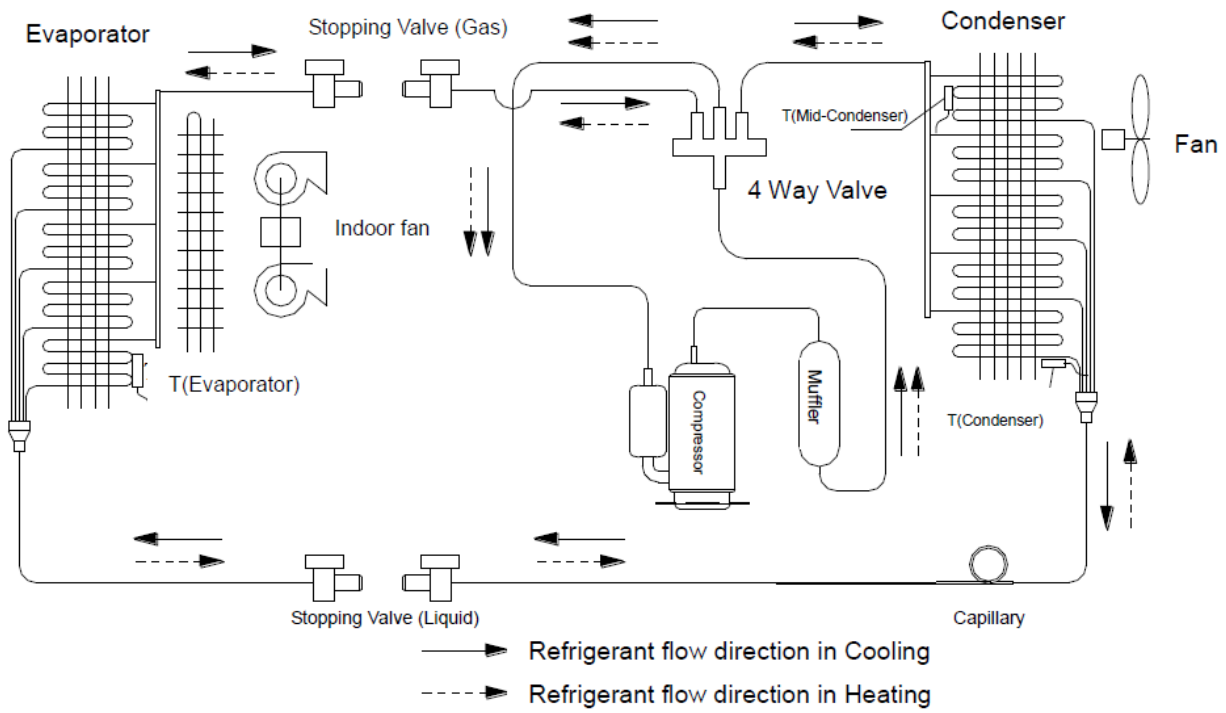

AL-H36/4R1(U),AL-H36/5R1D(U), AL-H48/5R1D(U), AL-H60/5R1D(U)

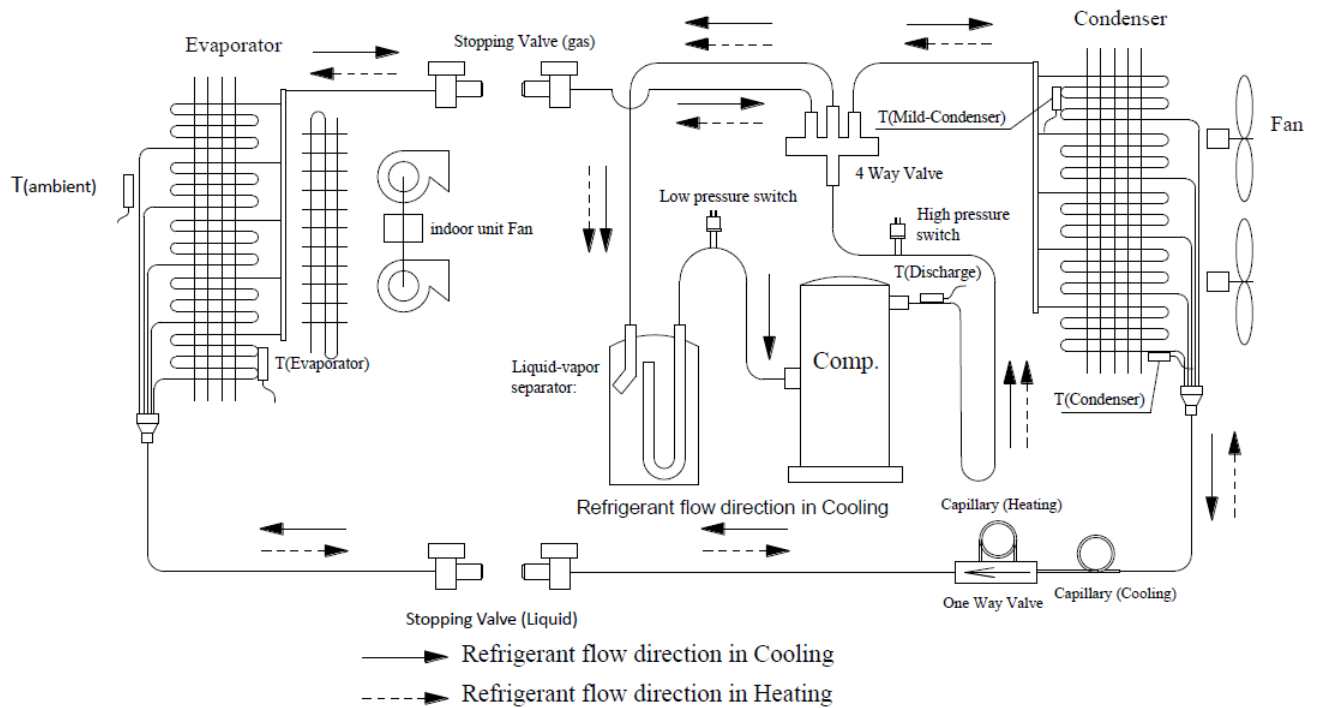

5. Electrical wiring and connection

AL-H12/4R1D(U), AL-H18/4R1D(U)

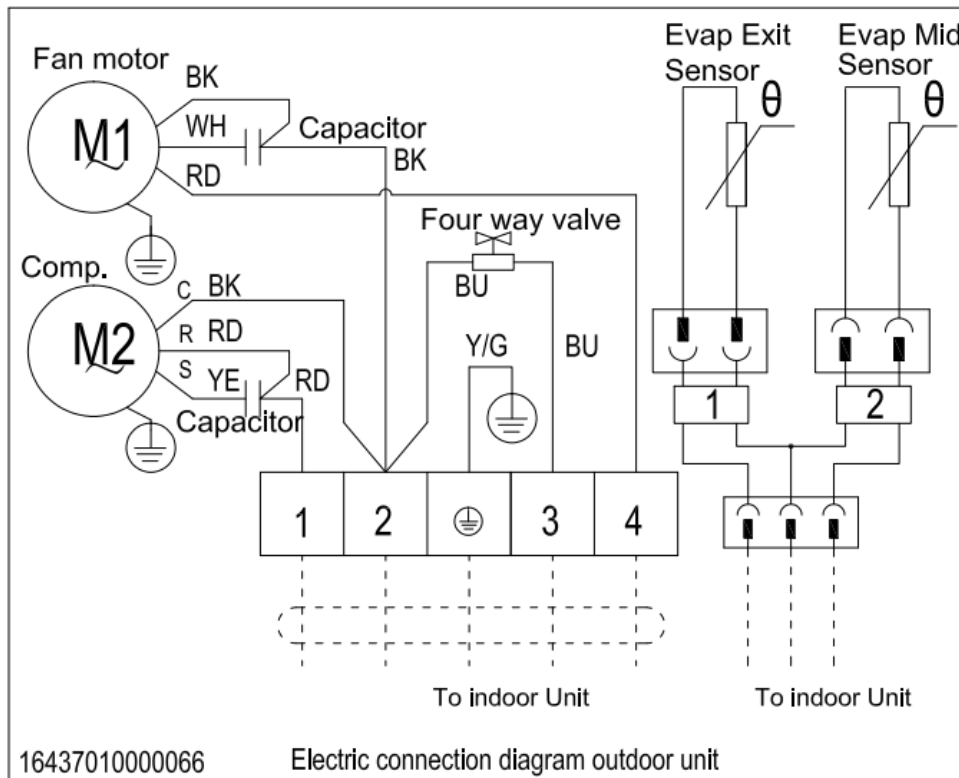

AL-H24/4R1D(U)

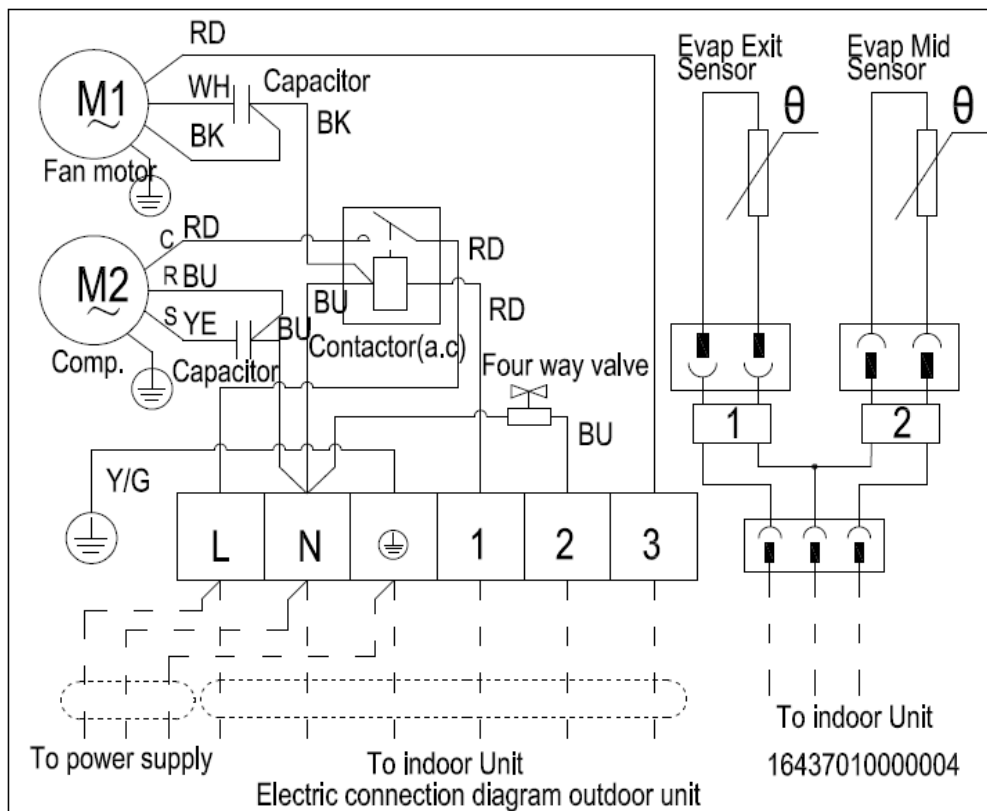

AL-H36/4R1(U)

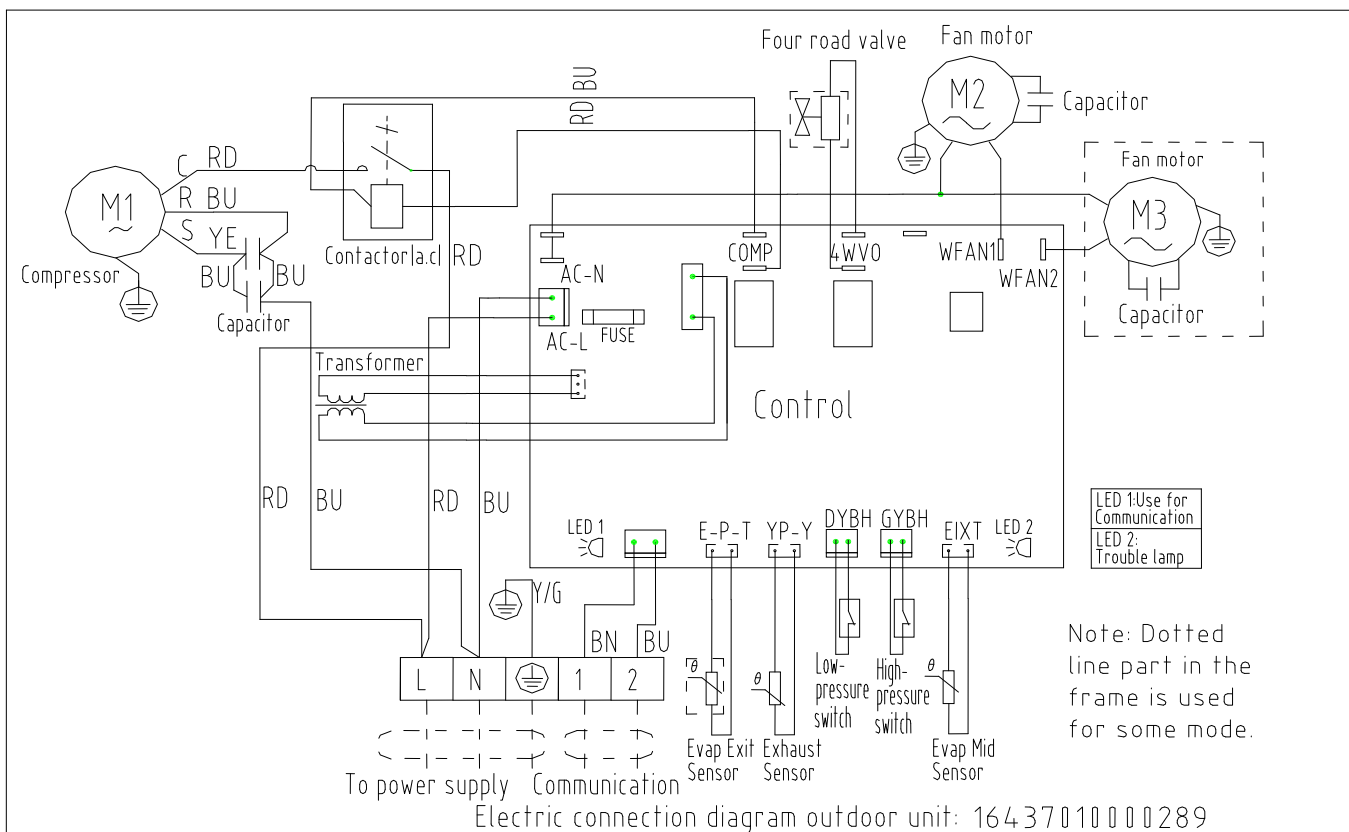

AL-H36/5R1D(U), AL-H48/5R1D(U), AL-H60/5R1D(U)

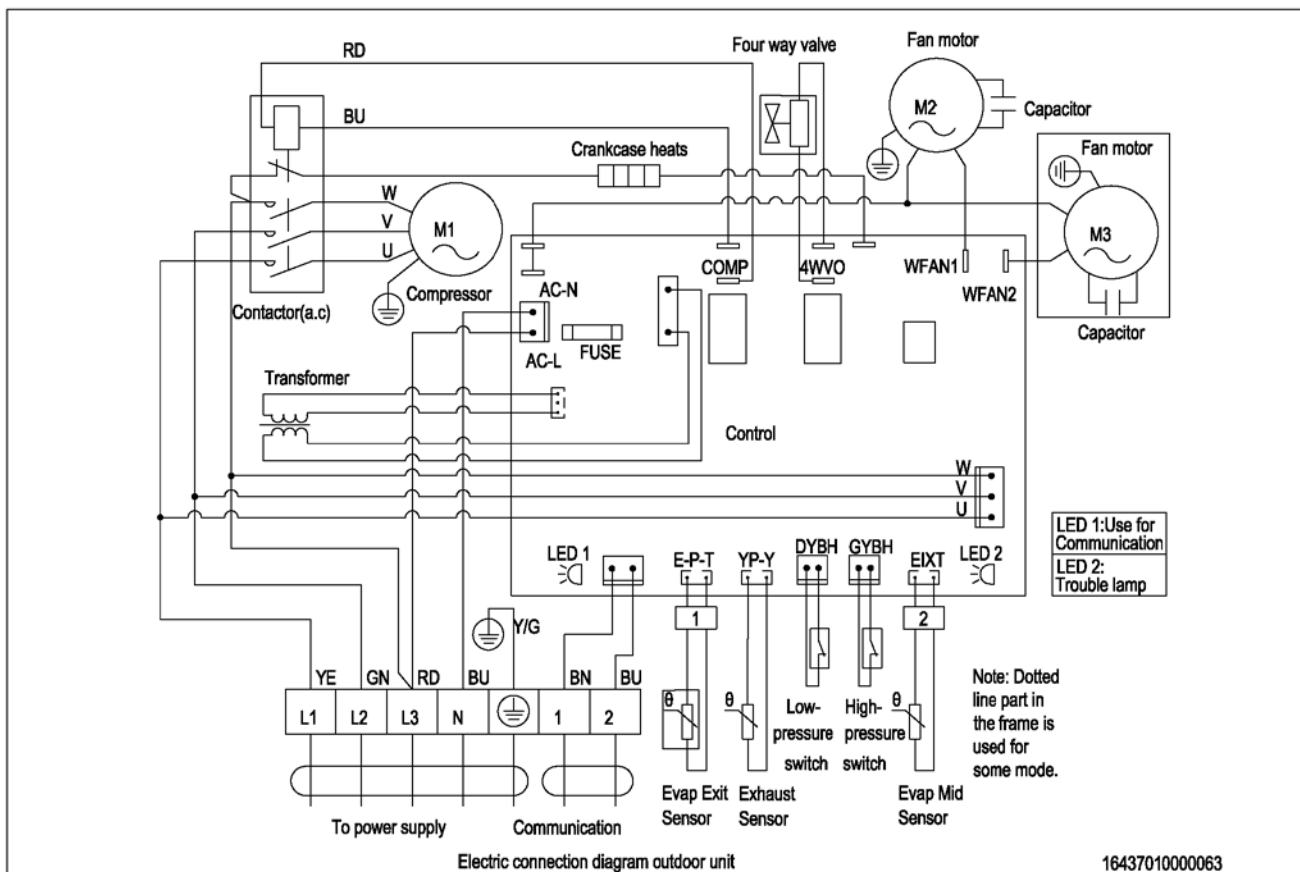

Introduction of Control Board QRD-SW3F-HCE1 (outdoor unit board) sockets (Power supply 380V-415V)

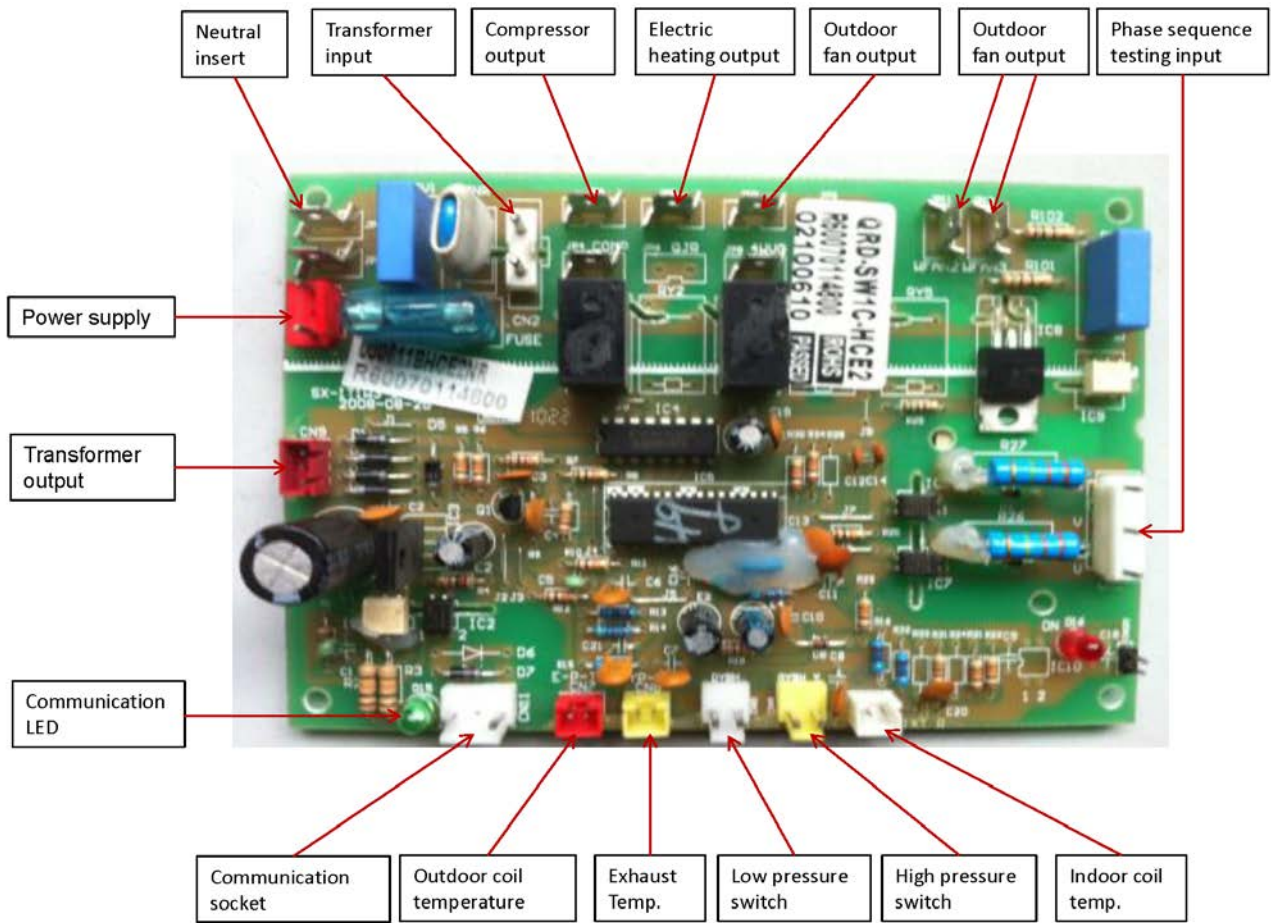

6. Explore View

AL-H12/4R1D(U) AL-H18/4R1D(U)

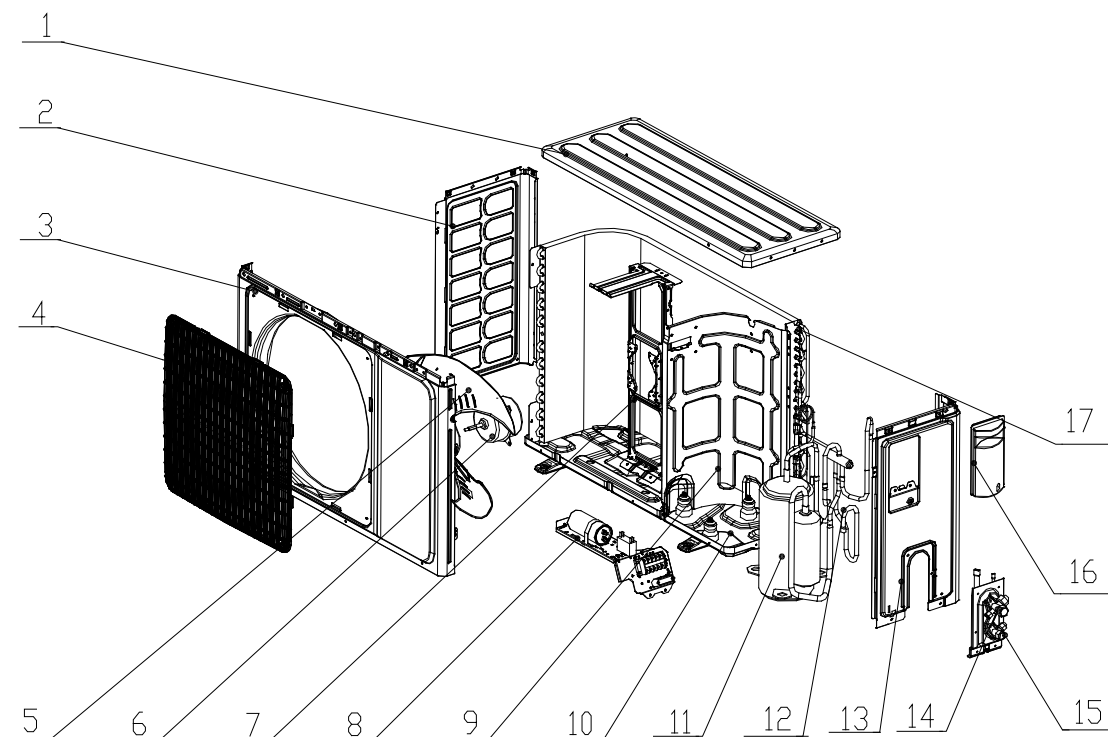

AL-H12/4R1D(U), AL-H18/4R1D(U)

No.	Chinese Name	Part Name	Quantity
1	顶盖板	Top Cover	1
2	左侧板	Left side panel	1
3	前面板	Front Panel	1
4	网罩	Grille	1
5	风叶	Fan	1
6	电机	Fan Motor	1
7	电机支架	Motor Bracket	1
8	电气总成	Control Box Assembly	1
8.1	压缩机电容	Compressor capacitor	1
8.2	风机电容	Fan motor capacitor	1
8.3	端子板	Terminal Block	1
9	隔风立板	Barrier	1
10	底盘组件	Base pan assembly	1
11	压缩机	Compressor	1
12	四通阀组件	4way assembly	1
13	右侧板	Right side panel	1
14	截止阀 1/2in	Stop valve	1
15	截止阀 3/8in	Stop valve	1
16	电器盖板	Control cover	1
17	冷凝器总成	Condenser assembly	1

AL-H24/4R1D(U)

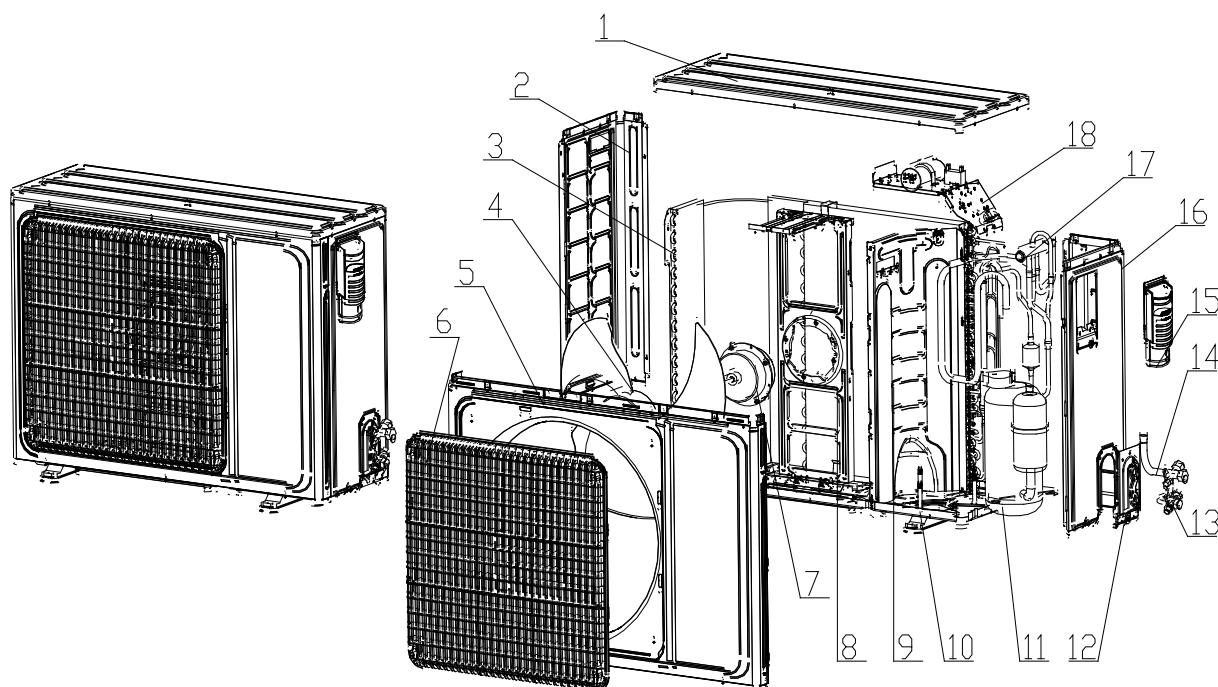

AL-H24/4R1D(U)

NO.	Chinese name	Parts name	Quantity
1	顶盖板	Top cover	1
2	左侧板	Left-hand board	1
3	冷凝器总成	Condenser assembly	1
4	轴流风叶	Axial flow fan	1
5	大面板	Big panel	1
6	网罩	Grille	1
7	室外电机	ODU fan motor	1
8	电机架	Motor support	1
9	隔风立板	Partition board	1
10	底盘组件	Chassis parts	1
11	压缩机及配件	Compressor	1
12	阀板	Valve board assembly	1
13	截止阀 5/8 inch	Stop valve	1
14	截止阀 3/8 inch	Stop valve	1
15	电器盖板	E-parts cover	1
16	右侧板	Right side panel	1
17	四通阀组件	Four-way valve assembly	1
18	电器架总成	E-parts bracket assembly	1
18.1	交流接触器	Relay contact	1
18.2	压缩机电容	Capacitor, compressor	1
18.3	风机电容	Capacitor, fan motor	1
18.4	温度传感器 0.5m	Sensor 0.5m	1
18.5	温度传感器 1m	Sensor 1m	1

AL-H36/4R1(U),AL-H36/5R1D(U)

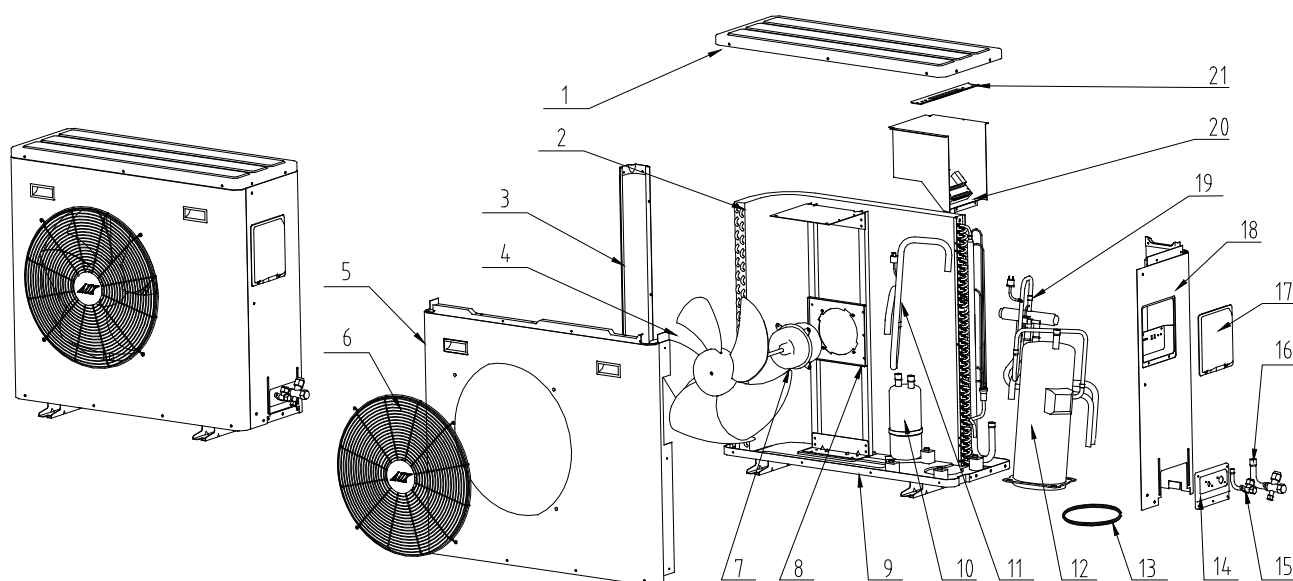

AL-H36/4R1(U),AL-H36/5R1D(U)

No.	Chinese Name	Part Name	Quantity
1	顶盖板	Top cover board	1
2	冷凝器总成	condenser assembly	1
3	左侧板	Left-hand board	1
4	电机架组件	Motor bracket assembly	1
5	室外风扇电机	Outdoor Motor	1
6	轴流风叶	Axial-flow wind leaves	1
7	面板	Big panel	1
8	面板网罩	Net for big panel	1
9	压缩机消音棉	Compressor muffler cotton (cylinder)	1
10	底盘组件	Chassis assembly	1
11	压缩机消音棉	Compressor muffler cotton top cylinder	1
12	气液分离器	Flash chamber assembly	1
13	回气管组件	Return air pipe assembly	1
14	压缩机	Compressor	1
15	四通阀管路组件	Four-way valve assembly	1
15.1	四通阀	Four-way valve loop	1
15.2	四通阀线圈	Four-way valve loop	1
15.3	消音器	Muffler	1
15.4	高压开关	High Pressure Switch	1
16	右侧板	Right-hand board	1
17	阀板	Stop valve board	1
18	截止阀组件 3/8in	Stop valve 3/8in	1
19	截止阀组件 5/8in	Stop valve 5/8in	1
21	电控总成	Electric assembly	1
21.1	电容	Capacitor for fan motor	1

21.2	端子板	Terminal board	1
21.3	电器架	Electric components box	1
21.4	交流接触器	AC contactor	1
21.5	控制板	PCB board	1
21.6	变压器	Transformer	1
21.7	传感器 1.3m	Sensor 1.3m	1
21.8	传感器 0.9m	Sensor0.9m	1
21.9	传感器 0.9m	Sensor 0.9m	1
22	电器架固定杆	Electric components bracket	1

AL-H48/5R1D(U), AL-H60/5R1D(U)

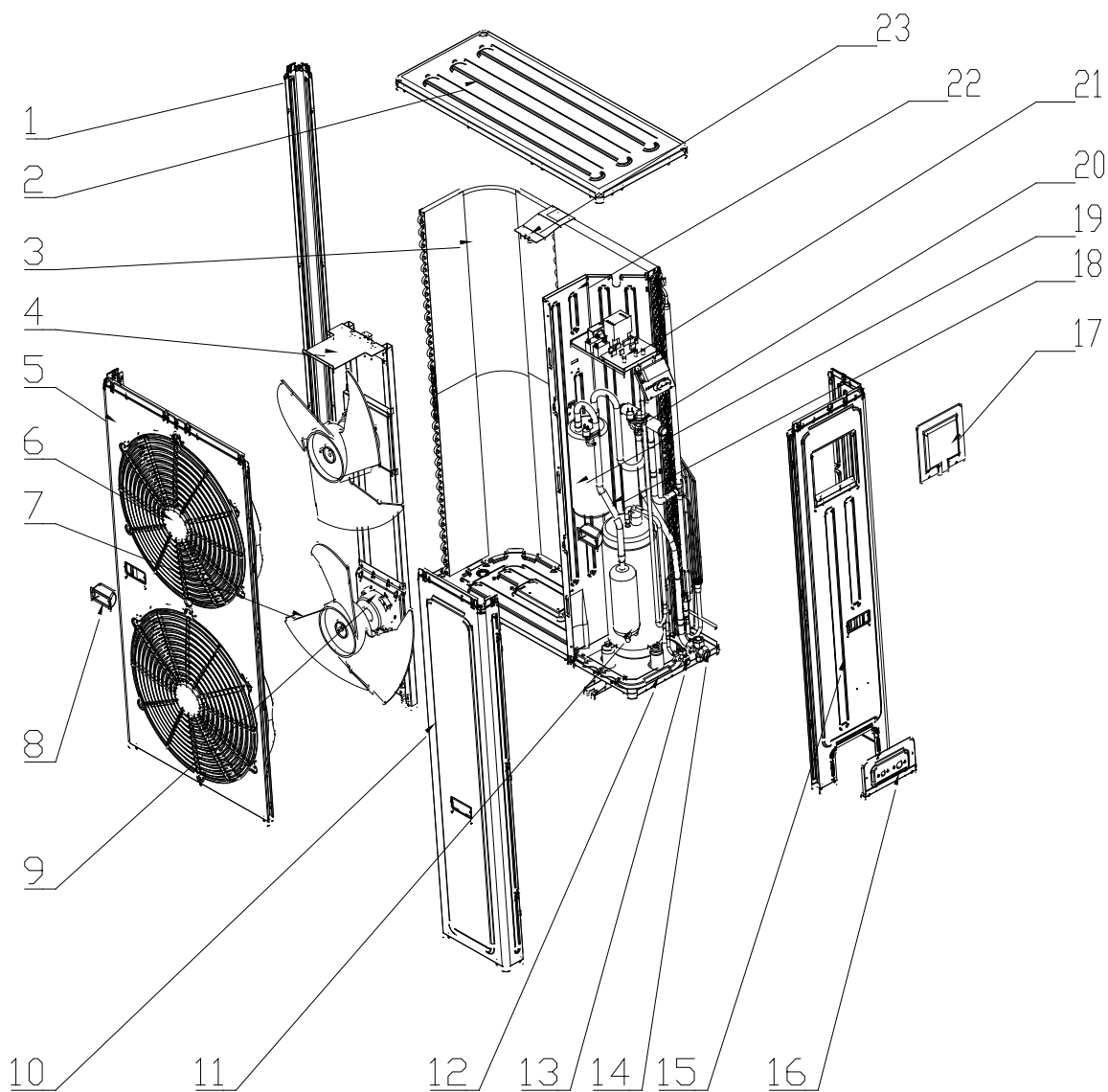

AL-H48/5R1D(U), AL-H60/5R1D(U)

NO.	Chinese name	Parts name	Quantity
1	立柱	Stand column	1
2	顶盖板	Top cover	1
3	冷凝器总成	Condenser assembly	1
4	电机架	Motor support	1
5	大面板	Big panel	1
6	网罩	Grille	1
7	轴流风叶	Axial flow fan	2
8	小挖手	Handle care	3
9	室外电机	ODU fan motor	2
10	小面板	Small panel	1
11	压缩机及配件	Compressor	1
12	底盘组件	Base pan assembly	1
13	截止阀 3/8 inch	Stop valve	1
14	截止阀 3/4 inch	Stop valve	1
15	右侧板	Right side panel	1
16	阀板	Valve board	1
17	电器盖板	E-parts cover	1
18	回气管	Suction pipe	1
19	气液分离器	Gas-liquid separator	1
20	四通阀管路组件	4way assembly	1
21	电器总成	Electric box assembly	1
21.1	控制板	Main PCB	1
21.2	变压器	Transformer	1
21.3	交流接触器	Relay contact	1
21.4	风机电容 3.5 μ F	Fan capacitor	1
21.5	端子板	Terminal Block	1
22	隔风立板	Barrier	1
23	冷凝器固定板	Condenser bracket	1

7. Installation

7.1 Preparation and equipments before installation

Please buy following spare parts from your local market before installation	Besides general implements, other implements are needed when connecting the pipe
Hung bolts M12, 4 pcs	Acetylene cylinders, oxygen cylinders (when longer pipe used it should be welded)
Drainage pipe PVC	One set pipe cut machine. (cut copper pipe)
Copper connecting pipe	Refrigerant cans, electronic balance (when longer pipe used additional gas should be charged)
Adhesive belt (big size) 5 pcs, (small size) 5 pcs	Pressure gauges, pipe clamp, welding torch, 2B silver electrode
Heat insulation material used to connect copper pipe (PE foam material, its thickness is more than 8mm)	Wrench 2 pcs, one of them is with adjustable torque wrench (42N.m,65N.m,100N.mm)
Power cable, electrical wire between indoor and outdoor unit(Must be in accordance with the wire diameter in the wiring diagram)	Nitrogen cylinder (in order to prevent oxidation when welding, using Nitrogen to replace the air)

Select installation position of outdoor unit

- ◇The site shall be strong enough to bear its weight, prevent noise and vibration.
- ◇The site shall be ensured to avoid direct sunshine, if necessary set a Havelock above the outdoor unit.
- ◇The site shall be easy to drainage the rain water and the frost water.
- ◇The site shall be ensured that the outdoor unit will not be covered by snow LDring the winter season.
- ◇The site shall be ensured that the outlet is not facing the strong wind.
- ◇The site shall be ensured that outlet air and operation noise will not affect the neighbors' daily life.
- ◇The site shall be ensured that the outdoor unit will not be affected by the garbage and oil mist.

Warning :

If outdoor unit working under such environment which contains oil (including machine oil) salt(marine areas), sulfide gas (hot springs and oil refinery areas), those substance may lead to the failure work of the outdoor unit.

Maintenance and ventilation space

- ◇The site shall be easy for ventilation then the outdoor unit can inhale and discharge air easily. What's more please reserve enough space for maintenance.

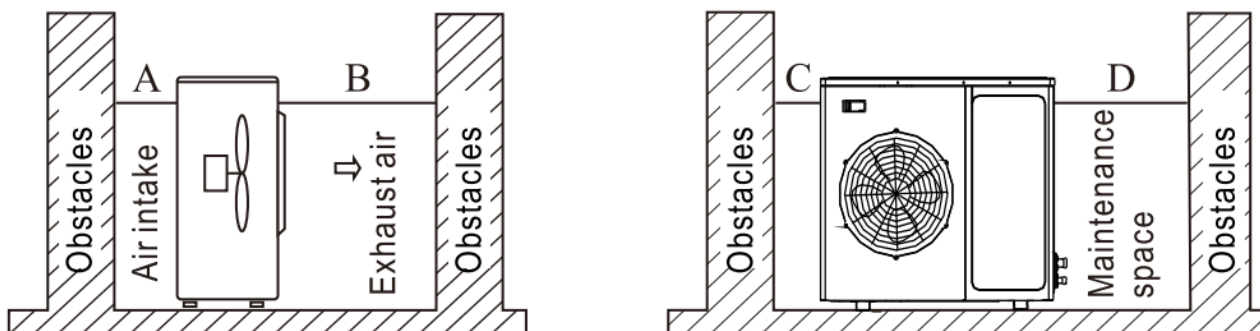

Note: Require A>300mm; B>1500mm; C>300mm; D>500mm

Outdoor unit installation

- ◇ Use size M10 bolt and nut to fasten the outdoor unit tightly on the bracket, keep it in the horizontal level. The suitable length for bolt shall 20mm over the base level, in order to minimize vibration please do set a rubber shock absorber.
- ◇ If the outdoor unit is mounted on the wall or on the rooftop, in order to prevent earthquake and strong wind please fasten it as tightly as possible.
- ◇ Set a drainage channel to ensure the condensing water can drain out smoothly.
- ◇ To avoid that only four angles metal sheet to support the outdoor unit.

7.2 Connection piping installation

Piping installation precaution

Please choose the phosphorus deoxidation seamless copper pipe as the piping.

- ◇ If use the lengthen piping needs welding:
 - Please welding before fasten the nut, when welding using nitrogen gas to replace the air in the pipe in order to prevent oxidation.
- ◇ If there are many points to be welded when installing the lengthen piping, please set a filter in the pipe(buy from local market)
- ◇ Please use nitrogen gas or air to remove the dust and water in the pipe,
- ◇ Please lay out the piping according to the tend towards of the piping, but it is not allowed more than 3 times curved at the same point of the pipe(if do like this the pipe will become rigid)
- ◇ Pipe bending machine is used during the process of bending the pipe, the curvature shall not be too small or it will affect the refrigerant flow.

Piping specification selection

As to the detail selection please take reference to the cooling capacity adjust index figure during different installation situations.

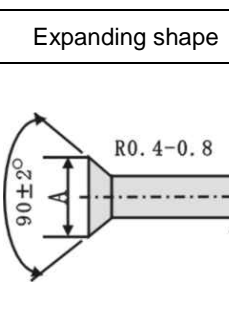
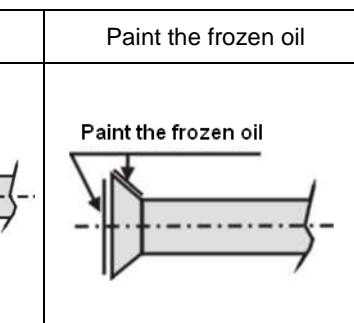
Piping diameter	Tighten torque	Expanding size	Expanding shape	Paint the frozen oil
1/4in(φ6.35mm)	15-19(N·m)	8.3-8.7mm		
3/8in(φ9.52mm)	35-40(N·m)	12.0-12.4mm		
1/2in(φ12.7mm)	50-60(N·m)	15.4-15.8mm		
5/8in(φ15.88mm)	62-76(N·m)	18.6-19.0mm		
3/4in(φ19.05mm)	70-75(N·m)	22.9-23.3mm		

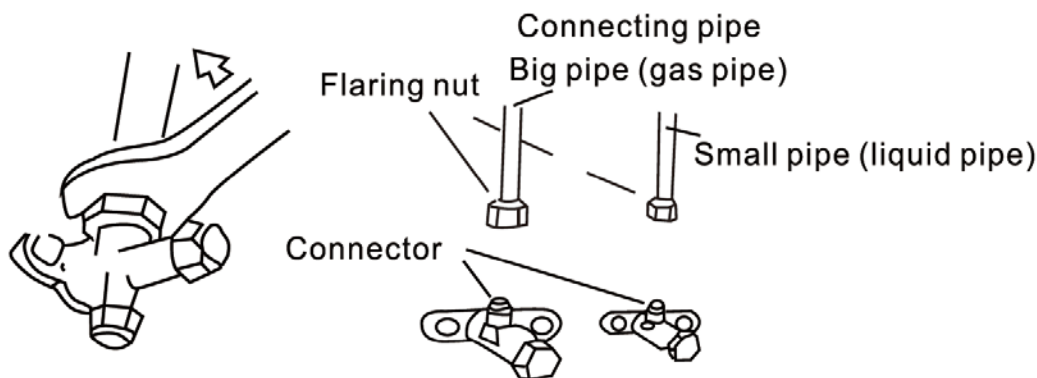

Piping connection

- ◇Using expanding machine to expand accessories, the size of horn shown in the above figure:
- ◇Paint a thin layer of frozen oil at both inside and outside part of the expanding.
- ◇Make the expanding right to the screw thread shape connection of the indoor unit, using hands to tighten the nut then using a wrench to tighten the nut again, the tighten torque as follows figure.
- ◇Take out the cover of the indoor unit gas valve and liquid valve, make the expanding right to the stop valve of outdoor unit, using hands to tighten the nut then using a wrench to tighten the nut again, the tighten torque as follows figure.

Equivalent pipe length conversion

Equivalent pipe length means converting pipe elbow to straight pipe length after considerate the pressure loss.

Elbow and Oil loop conversion tablet

Pipe Dia.(mm)	Bend	Oil Loop
6.35	0.10	0.7
9.52	0.18	1.3
12.70	0.20	1.5
15.88	0.25	2.0
19.05	0.35	2.4
22.02	0.40	3.0

Equivalent pipe length $L = \text{Actual Pipe length} + \text{Bend Qty} \times \text{Equivalent pipe bend length} + \text{Oil Loop Qty} \times \text{Equivalent Oil Loop length}$

Sample:

ALCA-H42A5/C5 Actual Pipe length is 25 meters, Gas pipe diameter is 19.05mm. If there's 5 bends and 2 oil loops during the installation, then the equivalent pipe length should be:

$$L = 25 + 0.35 \times 5 + 2.4 \times 2 = 31.5(\text{m})$$

◇Specification of connection pipe for indoor unit and outdoor unit

Cooling Capacity(Btu/h)		12000	18000	24000	36000	48000	60000
Connection Pipe (mm)	Liquid Pipe	Φ6.35		Φ9.52		Φ9.52	
	Gas Pipe	Φ12.7		Φ15.88		Φ19.05	
Max. Length		15	20	30	50	50	
Max. Height (m)		10	15	15	30	30	
Max. Bend Qty		3	4	6	10	10	
Extra R410a per meter when the pipe length is more than 5 meter (kg)		0.03	0.03	0.05	0.05	0.07	

Caution:

- 1.The standard Pipe length is 5m, if the pipe length is less than this then no additional charging is necessary. If the pipe length is more than this then you should charge more refrigerant into the system according to the above Charging Data
- 2.The thickness of the pipe is 0.5-1.0, bearing pressure is 3.040MPa;
- 3.If the connection pipe is too long, the cooling capacity and stability would be decreased. And the more bend quantity, the resistance in the piping system would be bigger, then the cooling and heating capacity would be decreased even lead to compressor broken. We suggest you to use the shortest connection

pipe according to the pipe length parameter in this manual.

Emptying or vacuum

Before charging the refrigerant to the system, to ensure that there is no impurities, water or non-condensable gas. So, emptying and vacuum operation should be carried out.

◇Vacuum: when process this operation please be sure that the connection pipe is tightened up.

1. Screw off the cover of maintenance valve connection, connect the pressure gauge to the connection of maintenance valve
2. Connect the vacuum pump to the pressure gauge, turn on the vacuum pump and pressure gauge to process the vacuum operation toward the indoor unit and piping, while to ensure that the absolute pressure is no less than 50Pa after this operation.
3. Turn off the pressure gauge and vacuum pump to keep the pressure in the same level in 20 minutes.

◇Emptying: when process this operation, please disconnect the high pressure valve with liquid valve.

1. Connect the gas valve of the stop valve to the thimble side of the rubber hoses, the other side of rubber hoses should be connected to the refrigerant tank.
2. Open the refrigerant tank valve, using the refrigerant inside the tank with high speed to empty the air in the indoor unit and the connection piping. When the outlet air becomes mist (it feels cold by touching it), then the air is emptied.
3. When ensure that the air is emptied, connect and tighten the high pressure valve of outdoor unit stop valve and liquid side connection pipe, keep this state more than 10 seconds.
4. Use soapy what to test each connection junctions (including lengthen piping welding junction)
5. Confirmed that there is no leakage, turn off the valve of refrigerant tank, take down the rubber hose as well.

◇Turn on the high-low pressure valve of the outdoor unit.

After vacuum and emptying, screw back the cover of the maintenance valve of outdoor unit low pressure valve, screw off the high-low pressure valve of the outdoor unit (note: shall totally turned off). Connect the refrigerant to the system.

Heat insulation package of piping

◇ Use heat insulation material with good insulation performanCF to wrap the pipe.

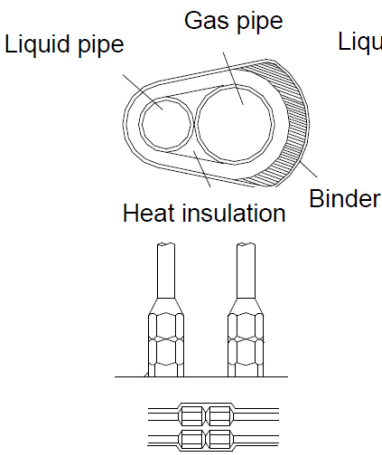
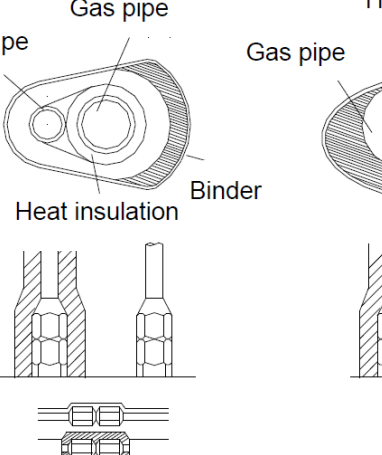
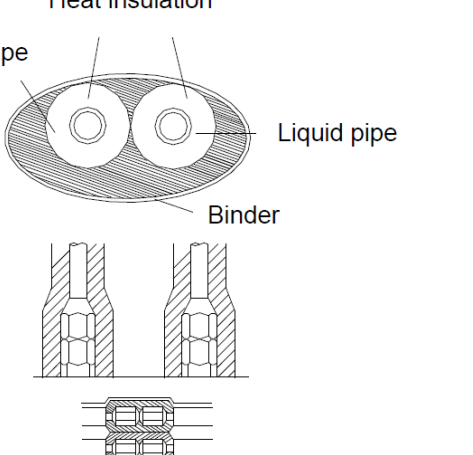
Incorrect	Correct	
Gas pipe and liquid pipe should not be put together to insulate	Insulate the gas pipe (cooling only)	Insulate the gas pipe and liquid pipe
		

Notes

Drainage pipe and connection piping should be wrapped by heat insulation material respectively or there will be dew or leakage

During the high temperature working environment, our air conditioner is proved my dew conditioner experiment. But if it keeps on working during the high humidity (the dew temperature is more than23°C) environment which may lead to water leakage, in such condition please use following additional insulation material:

- ◇ Glass fiber insulation material with the thickness between 10~20mm can be used.
- ◇ The part of indoor unit which get in touch with the back side of ceiling should pasted with insulation material.
- ◇ Besides the previously more than 8mm thick insulation material, connection piping (both gas pipe and liquid pipe), drainage pipe should be wrapped by additional 10~30 mm thick insulation material.

To seal the hole on the wall.

- ◇ To prevent rainwater or other foreign bodies from entering the room and air-conditioner after installing the tubing and drain pipe, the gap between wall hole and tubing, drain pipe and electric wire should be sealed with mastic, sealant rubber or putty, or poor performance or leakage will result
- ◇ If the outdoor unit is higher than indoor unit, tubing should be bent to ensure that the lowest point of the tubing is lower than the wall hole to prevent rainwater entering the room or air-conditioner along the piping system.

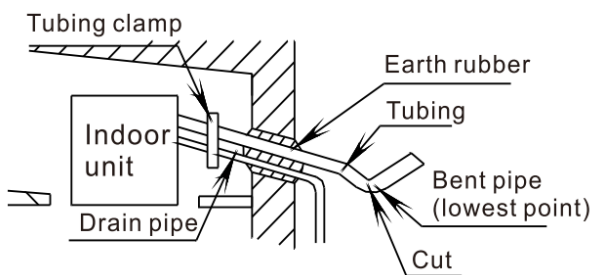

Make a cut in the heat insulation materials of bent pipe (for drainage)

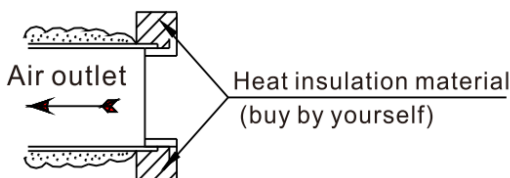

Additional refrigerant charge

When pipe length exceeds 5m, please add refrigerant according to the table below:

Connection piping	Piping size)		Additional refrigerant charge amount (kg/m)
	Gas pipe	Liquid pipe	
Piping between indoor and outdoor unit	φ9.52×0.75mm	φ6.35×0.75mm	0.02
	φ12.7×1mm	φ6.35×0.75mm	0.03
	φ15.88×1mm	φ9.52×0.75mm	0.05
	φ19.05×1mm	φ9.52×0.75mm	0.07
	φ19.05×1mm	φ12.7×1mm	0.09

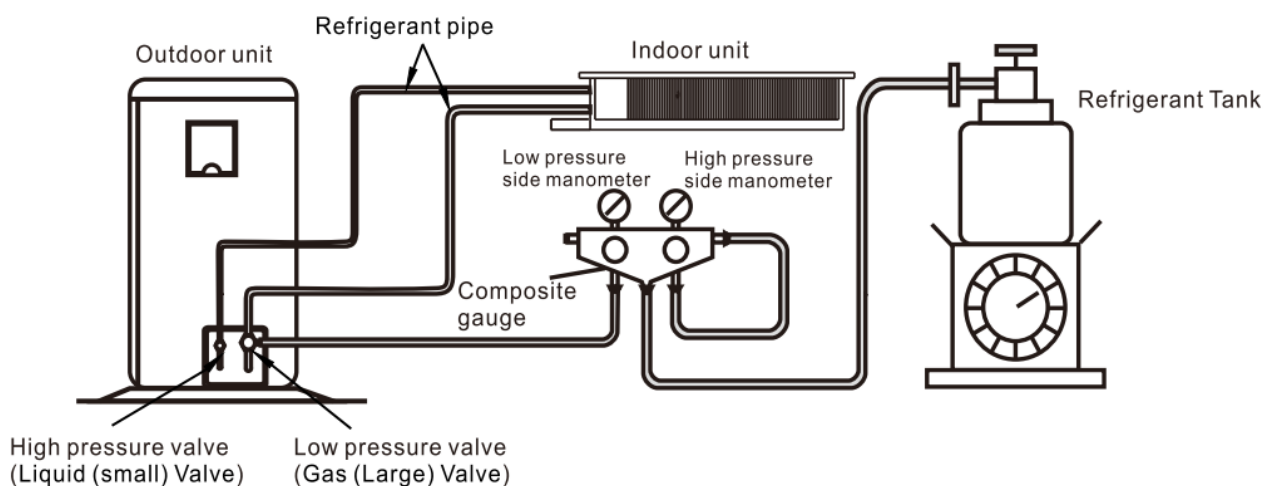

Others

Users to install the air conditioner at site shall ensure that the oil can return to the unit smoothly.

- ◇Horizontal pipes should incline toward the outdoor unit using a 20:1 slope
- ◇If there is a height difference between the indoor and outdoor unit, oil loops should be installed in the interconnecting gas (large) pipe;

When the vertical pipe height difference is less than 5 meters, an oil loop should be installed at the bottom of the gas (large) pipe;

When the vertical pipe height difference is more than 5 meters, then for every 5 meters an oil loop must be installed at the bottom of the gas (large) pipe, and a short loop (liquid ring) should be installed at the exit of the indoor unit liquid (small) pipe;

When the connecting gas pipe vertical height difference is less than 5 meters but the constant rise distance is too long, an oil loop should be installed in the gas (large) pipe every 10 meters.

◇When the outdoor and indoor units are at the same elevation, the oil deposit bend and liquid ring do not need to be installed, if the horizontal connecting pipe length is less than 10 meters.

When the horizontal connecting pipe length is more than 10 metres, install an oil loop in the gas (large) pipe every 10 metres.

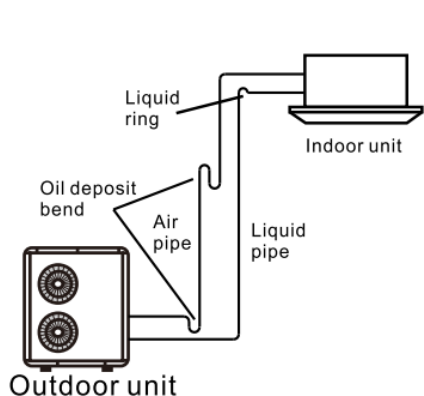

When the installation position of indoor unit is higher than that of the outdoor unit.

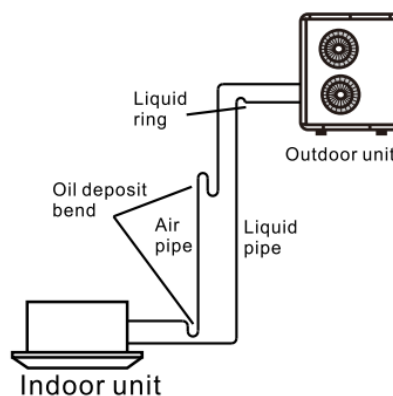

When the installation position of indoor unit is lower than that of the outdoor unit.

Note:

This chart is for explanation purposes. An actual installation will differ from this according to the site conditions. When making an oil trap the radius of the bend should be between 1.5 and 2 times the pipe diameter.

7.3. Electrical connection

7.3.1 Electrical connection precaution

Warning	<p>Installation of electric items must be carried out by qualified, professional technicians. An isolated circuitry should be fixed with whole-pole disconnection devices, which is with at least 3mm gap of touch point. .</p> <p>Power supply and indoor to outdoor connection should use special cable. Providing the necessity of installation or replacement, the professional technician of service store appointed by manufacturer must be required, while self-operation by users is prohibited.</p>
	<p>In case of any electric shock accident, the creepage protection devices /power supply on-off and breaker must be required with power supply.</p>
	<p>The specification of fuse for single phase control board is F5AL 250V, while for 3 phase control board, both indoor and outdoor unit, it is F3.15AL 250V.</p>
	<p>Machine must be earthed surely. If not, it'll be probably caused creepage.</p>
	<p>Equivalent 227IEC53(RVV) type of power cord of GB5023 or the excelled must be required. The cords should be fixed properly against broken, while ends/joints of cords is under outside force. Improper connection or fixation will cause disaster like fire....etc. Equivalent 245IEC57(YZW) type of power cord of GB5023 or the excelled must be used as connection line of indoor and outdoor.</p>
Notice	<p>The earth line is neither allowed to connect to gas pipe, water pipe or circuitry of telephone or lighting rod, nor to the earth line of other devices.</p>
Others	<p>Please fix power supply cord and connection wires of indoor and outdoor, in accordance with circuit diagram</p> <p>Fix the cords into terminal boards properly and safely with cable fixation tools to avoid any danger caused by the power cord under outside forces.</p> <p>After fixation, use bind tape (affixed) to bind wires avoiding any collision with other components like compressor, copper pipes...etc</p>

7.3.2 Electrical connection

Wiring diagram of indoor & outdoor, refer to the section of part 1

Recommendation of power supply cord

Power supply:220V-240V~,50Hz

Cooling capacity (Btu/h)	Model	Power supply spec.	Power supply side	Power supply cord	Connection wires
12000	ALCA-H12/4R1AA ALCF-H12/4R1C ALMD-H12/4R1D	220-240V~50Hz	Indoor side	3×2.5mm ²	3×2.5mm ² +2×1 mm ²
18000	ALCA-H18/4R1AA ALCF-H18/4R1C ALMD-H18/4R1D	220-240V~50Hz	Indoor side	3×2.5mm ²	3×2.5mm ² +2×1 mm ²
24000	ALCA-H24/4R1AA ALCF-H24/4R1C ALMD-H 24/4R1D	220-240V~50Hz	Outdoor side	3×6mm ²	3×2.5mm ² +3×1mm ²
36000	ALCA-H36/4R1E ALCF-H36/4R1 ALMD-H 36/4R1	220-240V~50Hz	Outdoor side	5×4mm ²	3×4 mm ² +2×1mm ²

Power supply 380V-415V~,3N,50Hz

Cooling capacity (Btu/h)	Model No.	Power supply spec.	Power supply cord of indoor unit	Power supply cord of outdoor unit	Connection wires
36000	ALCA-H36/5R1AA ALCF-H36/5R1C ALMD-H36/5R1D	Outdoor unit 380-415V 3N~50Hz Indoor unit 220-240V~50Hz Indoor and outdoor input separately	3×1 mm ²	5×4mm ²	2×1 mm ²
48000	ALCA-H48/5R1AA ALCF-H48/5R1C ALMD-H48/5R1D				
60000	ALCA-H60/5R1AA ALCF-H60/5R1C ALMD-H60/5R1D				

Notice:

- ◇ Above mentioned power supply cord is the cable which connect air on-off of indoor to indoor/outdoor unit. Power supply cord of indoor/outdoor unit is the power supply cable connecting indoor and outdoor unit
- ◇ The section area of power supply cord core is minimized one. To avoid voltage pressure dropped down, while longer power supply cord needed, the section area should be enlarged for one gauge.
- ◇ The connection wires to indoor unit is the cable of 27IEC53(RVV) type, 300/500V; while the connection wires to outdoor unit and the connection wires from outdoor to indoor unit is the multi-end of cable (neoprene)of 245IEC57(YZW)type,300/500V. if the single core with double skin type of cable is chosen for installation,, please choose 1# gauge of section area and wrapped with special jacket for

electrician.

- ◇ All of the ceiling/floor type unit is without accessorial electric heating

7.3.3 wire connection

Remove electric control box cover of indoor unit, connect the wires in accordance with the electric diagram mentioned on the back of the cover. The wire ends must be tightly fixed into terminal boards without ease. The earth wire must be fixed into appointed position.

Outdoor wire connection

- ◇ Remove the electric item cover, which is positioned in the right side of outdoor unit, connect the wires in accordance with the electric diagram on the back of the cover.
- ◇ Be sure that pressing the wires tightly with the terminal boards while it through the board, the wire ends must be tightly fixed into terminal boards. The earth wire must be fixed into appointed position.
- ◇ After all the wire connected, bundle connection pipe, connection wires and drainage pipe with strips like mentioned drawing below:

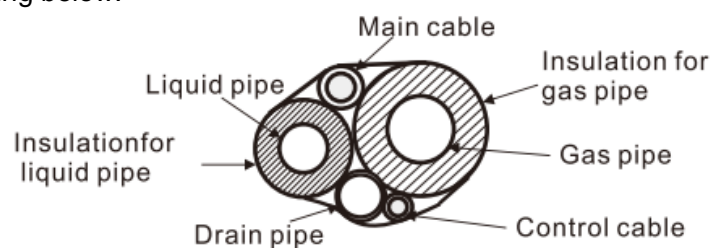

Notice:

- ◇ Compressor of AL-(H)36/5R1 (U) , AL-(H)48/5R1 (U), AL-(H)60/5R1 (U) are 3 phase power supply with phase sequence protection in its outdoor control board. Please be careful with wire connection.
- ◇ Be sure do't make the drainage pipe flat while bundled.

7.4. Commissioning

After installation, machine can be started commissioning.

Check installation condition

- ◇ Check indoor/outdoor unit installation and wire connection in accordance with the requirement of service manual.
- ◇ Check the power supplying, diameter of wires, air on-off and make it sure that the items can be matched with machines and, earth wire connection safety.
- ◇ Check air inlet/outlet duct and make it sure that the items is clean, operating smoothly.

Commissioning

- ★ During winter, the first run of performance should be supplied power 8 hours in advance to warm-up the crankcase.
- ★ During winter, while after 8 hours power off, the performance test should be 2 and half hours power on later:
 - ◇ Power on, run machine with cooling mode.
 - ◇ After 3 minutes compressor protection, check if there is normal cooling air come from indoor unit and if there is abnormal noise come from indoor/outdoor units
 - ◇ Configure the mode with "fan" and check if there is high air come from indoor unit.
 - ◇ Operate "swing" mode, check if the louver is properly swaying.
 - ◇ Press the other buttons on the remote controller and check if the complete unit is on proper working

condition

- ◇ Operate machine 1 hour with “cooling” mode and check if the drainage system is on proper condition
- ◇ Switch the mode for “heating” and check if there is warm air come from indoor, if there is abnormal noise come from indoor/outdoor units
- ◇ After confirmation of normal working condition, press the “on-off” to stop running machine.
- ◇ Then and there, train the end users with operation, maintaining and special notice.

7.5. Compressor freezing oil brand and standard oil charge

Outdoor model	Brand	Compressor Model	Compressor Lubricating Oil Model	Oil charge (cm ³)
AL-H12/4R1D(U)	HIGHLY	ASL150UV-C7LU	HAF68D1	450
AL-H18/4R1D(U)	HIGHLY	ASL205UV-C7EQ	HAF68D1	480
AL-H24/4R1D(U)	HIGHLY	ASH286UV-C8DU	HAF68D1	570
AL-H36/4R1 (U)	HITACHI	ATH420MV-C9EU	HAF68D1	840
AL-H36/5R1D(U)	HIGHLY	ATH420UC-C9EU	HAF68D1	840
AL-H48/5R1D(U)	HIGHLY	ATE498SC3Q9RK1	HAF68D1	1600
AL-H60/5R1D(U)	HIGHLY	ATE590SC3Q9JK	HAF68D1	1850

7.6 Daily maintenance

Clean inhaler

- ◇ Before cleaning the filter, ensure the unit is switched off and the power is off;
- ◇ Forbidden to use water clean the filter , it will hurt PCB or get an electric shock;
- ◇ When cleaning filter net, be sure you are standing steady, if you use ladder or others, please be careful.

Washing filter net

- ◇ Use vacuum or water to clean the net;
- ◇ In order to ensure the best performance from your air conditioner clean the air filter regularly
- ◇ We recommend cleaning once a month or more frequently if required.
- ◇ When the filter is very dirty it can be washed in detergent and hot water (below 45°C);
- ◇ Ensure the filter is fully dry before reinstallation to avoid risk of electric shock or short circuiting;
- ◇ Do not dry the filter using direct sunlight;



Check at the beginning of each season

- ◇ Check whether there are no physical obstructions at the air inlet or outlet of either indoor or outdoor unit;
- ◇ Check whether there are some garbage at the water outlet;
- ◇ Check whether electrical cables are in good condition, particularly the earth cable;
- ◇ When power on, check weather letters display on the screen of the wired controller.
- ◇ When working in winter, must connect power for 8 hours before switch on unit.

Check at the end of service season



- ◇ Operate for 2 3 hours under the ventilation condition; remove the moisture of the indoor unit.;
- ◇ If not use air conditioner in a long time, please close the power to save energy, the letter will disappear on wired controller;
- ◇ Take the batteries out of remote controller;
- ◇ Suggest that use dustproof to cover the outdoor unit.

Part 4 Trouble shooting

1.Main components of air conditioner	113
2.Electrical system main components	116
3.Poor efficiency explanation	118
4.Failure phenomenon	119
5.Electric components malfunction inspection	120
6.Failure code display	121
7.Failure analysis	123

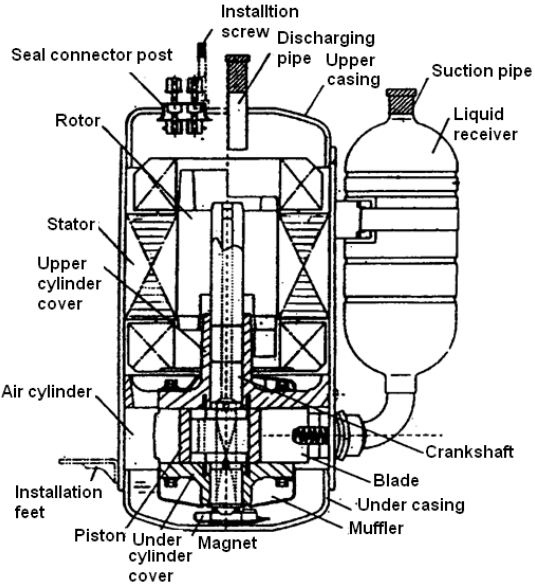
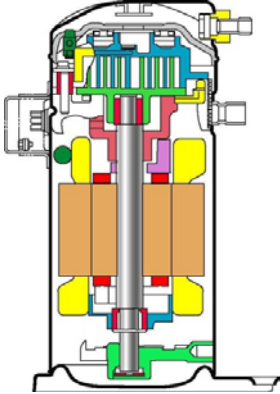
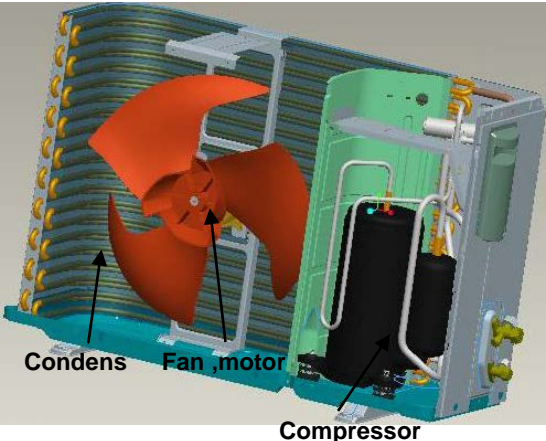

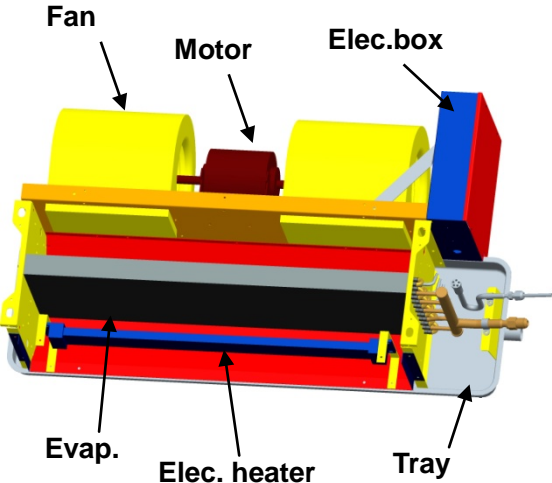
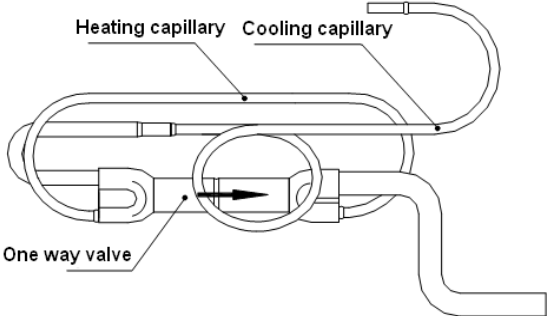
1.Main components of air conditioner

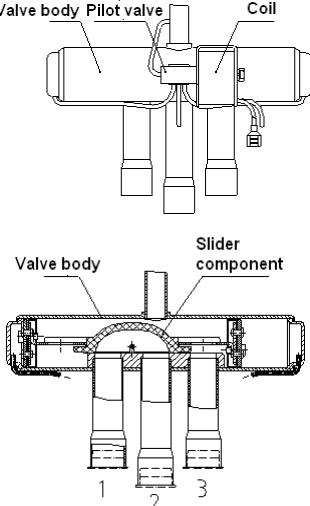
Appellation	Figuration and inner configuration	Instruction
<p>Rotary compressor</p>		<p>The function of compressor: after refrigerant evaporate in evaporator, compress the low temp and low pressure refrigerant gas, make the gas become high temp and high pressure gas, and then send the gas to condenser, make the refrigerant cycle, in this series products, all the compressors are complete hermetic compressor, in which motor and compressor are together.</p>
<p>Scroll compressor</p>		
<p>condenser (heat exchanger)</p>		<p>The function of condenser: Make the high temp and high pressure refrigerant gas discharged by compressor become liquid [make the gas heat exchange with air], (mark: when heating, condenser become evaporator)</p>

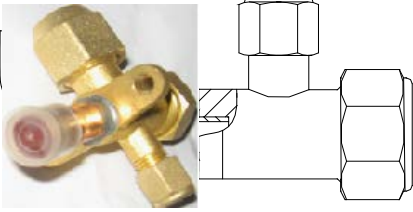
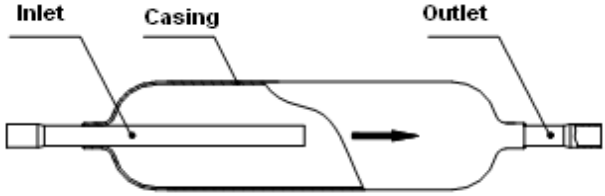
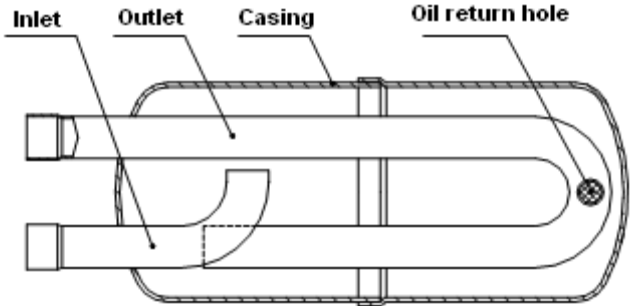
<p>Evaporator (heat exchanger)</p>		<p>Function of evaporator: Make the low pressure refrigerant liquid from capillary or expansion valve happen heat exchange with air</p>
<p>Capillary (throttle components)</p>		<p>Function of capillary: Utilize aperture and length change bring pressure gap., control refrigerant flow quantity and pressure</p>
<p>One way valve</p>		<p>One way valve is used for heat pump unit, it make the refrigerant liquid only flow as the arrow direction</p>
<p>Four way valve</p>		<p>Function of 4 way valve: When change cooling mode into heating mode, it will change the flow direction of refrigerant; When heating, the valve get electricity (cooling without electricity), the slip assembly move to the right connect pipe 2 and 3, so change the flow direction.</p>

<p>Stop valve</p>		<p>Function: To stop or release refrigerant, only on/off, can't adjust or throttle</p>
<p>Muffler</p>		<p>Function: Eliminate the system noise</p>
<p>Gas and liquid separator</p>		<p>Function: Separate liquid and gas refrigerant, to protect the compressor</p>

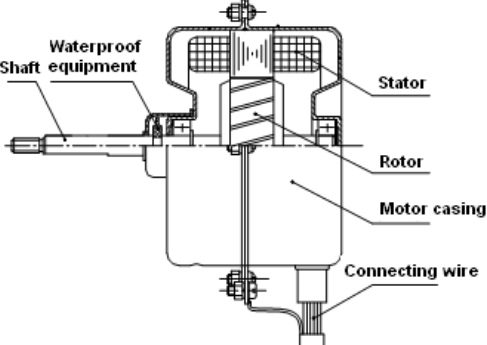
2. Electrical system main components

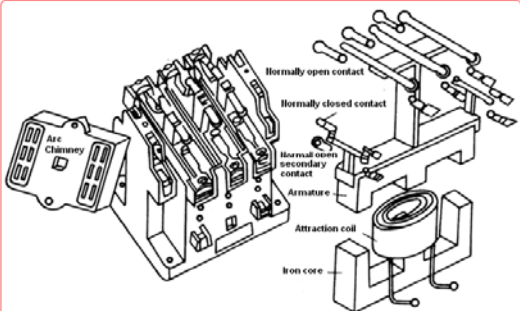
Appellation	Figuration and inner configuration	Instruction
PCB		<p>Function: Via program to control the relay, make every components on/off according to temperature and pressure variety, so to realize automatic control</p>
Fan motor		<p>Function: Drive the fan, make the indoor and outdoor unit have heat exchange with air.</p>
Pressure switch		<p>Function: To avoid the air conditioner work in a abnormal pressure, making the air conditioner work safety.</p>
Capacitor		<p>Induce the single-phase motor produce gyre magnetic field, connect with the accessory winding, and participate in the operation.</p>
AC Contactor		<p>When AC contactor's inner magnetic loop without power, the counter force of spring and the weight of armature core will make the main connector disconnect, when the magnetic loop with power, it will make the main connector connect, the power is on, accessories contactor will act.</p>

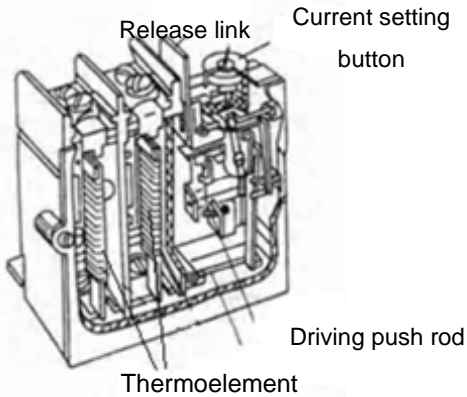
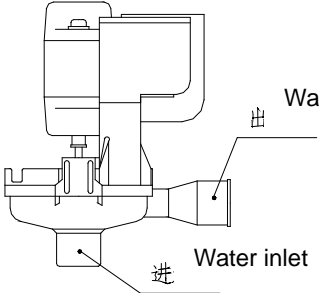
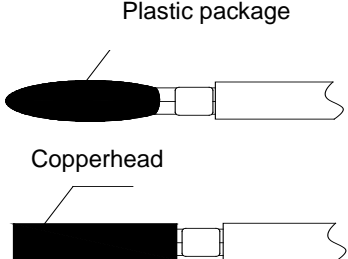
<p>Heat relay</p>		<p>Heat relay is normally made up of double metal sheet, when the current is too large, the double metal sheet will heat distortion and movement, and open the protection contactor ,which causes control circuit disconnect and then the main circuit will be cut off, after it cooling, control circuit will restore connection, but the main circuit is still disconnect, need to press start button to restart unit,</p>
<p>Condensate pump</p>		<p>Only for Cassette, the pump head is 1.2 meter,the condensate pipe must have over 1/100 descend angle, after unit cooling or dehumidify stops running, the pump will still work 3 minutes to clean the condensate.</p>
<p>Sensor</p>		<p>Physical properties will change along with the temperature, pressure change,used for check temperature and pressure.</p>

3.Poor efficiency explanation

During the process of using air conditioner, some phenomenon seems to be malfunction but actually not. Thus when cooling effect does not achieve to your expectation, the following factors have to be ruled out

Phenomenon	Causing explanation
High outside temperature and too many indoor individuals, even air conditioner runs at full-load operation, the wind blowing out from air outlet is cold, but it is difficult to lower the indoor temperature, this is not malfunction.	When the outdoor temperature is higher, more heat penetrates into indoor space, which increases the cooling load of AC. If there are too many individuals(for example 10 individuals) and every individual gives off 120W, totally 1200W, this will running out of half of AC cooling capacity, and the unit's cooling capacity this time is far from enough, indoor temperature is hard to lower down. It is normal phenomenon and do not mean useless of AC.
Power voltage is too low, causing AC uneasy to start and shut down after starting, or fuse be burned out etc.	It is not malfunction, need to find out the causing, if the causing is the electricity net voltage is too low, user should load a power manostat to keep voltage between 220V-380V for AC normally running
Select high wind speed but indoor temperature still at high side, air flow from the air outlet is too weak.	It is because air filter is too dirty or blocked making cooling capacity fail to be brought by air flow, causing cooling capacity inadequate. Take out filter and wash, the problem will be solved.
Select high wind speed, the vibration and sound of unit are severe.	Fan runs at high speed, severe vibration and sound of unit is normal phenomenon
Temperature controller adjusts improper and max cooling capacity is not utilized completely, thus indoor temperature can't lower down.	Adjust the temperature controller, and problem will be solved.
As for Heat pump air conditioner heating effect is not ideal during cold winter, this is normal phenomenon.	The lowest temperature is -7°C when heating, below this temperature unit cannot heat effectively.
Improper installation will lead to indoor temperature uneven or bad cooling effect.	It is necessary to adjust AC installation position

4.Failure phenomenon

Phenomenon	Causing explanation
Mirage comes out from indoor unit	When the cold air from AC cools the indoor air
Noise	<ol style="list-style-type: none"> 1. When air conditioner stops running, there will be some noise, and this is because the refrigerant flows contrarily. 2. AC expand or shrink according to temperature, causing harsh sounds 3. Liquid sound is from refrigerant flowing
Sometimes, the room is smelly	<ol style="list-style-type: none"> 1. The AC itself will not be smelly, if it is smelly, it is because environment smell accumulated 2. Solution: clean the filter
when heating, there is no wind at the beginning of starting unit	<ol style="list-style-type: none"> 1. It is to prevent cold air blowing, please be patient 2. The unit has auto-restart function, when it is repowered again, unit will run according to the mode which is set before the power off. (Note: default is closed)

5. Electric components malfunction inspection

No	Component name	Inspection methods
1	Compressor	Using multi-meter ohm phase, there is correct resistance value among windings (single phase compressor refers to specification, three phase compressor resistance approximately equal), resistance of winding should be infinite.
2	Control board	<ol style="list-style-type: none"> 1. Check if any connection part of PCB loosen or drop off, printed tinsel and components have any burn, fade, breaking off or aging phenomenon, all joints exist short circuit phenomenon etc. 2. Test the circuit board system in the term of voltage, pulse on, resistance variation, by using testing meter. 3. Judge the output and input is normal or not according to electric principle diagram
3	Contactor	<ol style="list-style-type: none"> 4. Press the contactor by hand, the contactor reacts immediately and without question 5. The contacting point of contactor has no burn and melt phenomenon 6. The winding has resistance value below 1000, but cannot be nil or infinite
4	4-ways valve winding	The winding has resistance value below 1000, but cannot be nil or infinite
5	Capacitor	<ol style="list-style-type: none"> 7. No expansion phenomenon apparently 8. Measure capacitor by using capacitor phase of multi-meter(if the multi-meter has no capacitor phase, use ohm phase, contact the two terminal of meter to two feet of capacitor, and quickly switch positive pole and negative pole and reconnect, the resistance should display from nil to infinite quickly. The resistance can't change is always nil or infinite).
6	Sensor	<ol style="list-style-type: none"> 9. Using multi-meter to measure resistance, find out temperature according to resistance table, the temperature should accord with sensor temperature. 10. Resistance cannot be nil or infinite
7	Motor	<ol style="list-style-type: none"> 11. No burning trace apparently 12. Using multi-meter ohm phase, there is correct resistance value among windings (single phase compressor refers to specification, three phase compressor resistance approximately equal), resistance of winding should be infinite.

6.Failure code display

When air condition has failure, the timing lamp on light board of controller will display different code according to different failure case.

6.1 Unit failure code for unit power supply is 220-240V

Failure causing	Display mode 1 (indication lamp on display lamp board)	Display mode 2 (wired controller)	Display priority	Phenomenon
Communication failure	none	E5	1	shutdown
Drainage system failure	Timing lamp flash 4 times/8s	E4	2	shutdown
Phase failure, phase-loss or low voltage failure	Timing lamp lash 6 times/8s	E6	3	shutdown
Indoor temperature sensor abnormal (TA)	Timing lamp flash 1 times/8s	E1	4	shutdown
Indoor coil sensor abnormal(TE)	Timing lamp flash 2 times/8s	E3	5	shutdown
Outdoor coil sensor abnormal(TW)	Timing lamp flash 2 times/1s	E2	6	non-stop
Indoor heating over-load protection		None	7	shutdown
Defrosting(not failure)	Operation lamp flash	None	8	non-stop

6.2 Unit failure code for unit power supply is 380-415V

Failure causing	Display mode1 (indication lamp on display lamp board)	Display mode1 (failure lamp on control board)	Display mode3 (wired controller)	Display priority	Phenomenon
Communication failure	Flash 5 times and go out 2S	Flash 2 times and go out 2S	F1	1	shutdown
Wired controller communication failure	—	—	E5	1	shutdown
Drainage system failure	Flash 4 times and go out 2S	—	E4	3	shutdown
Outdoor protection(Phase failure)	Flash6 times and go out 2S	—	E6	2	shutdown
Outdoor protection (discharging over-temperature)	Flash 10 times and go out 2S	Flash 10 times and go out 2S	EA	7	shutdown
High pressure protection	Flash 9 times and go out 2S	Flash 1 times and go out 2S	E9	6	shutdown
Low pressure protection	Flash 9 times and go out 2S	Flash 3 times and go out 2S	E9	6	shutdown

Indoor temp. sensor abnormal(TA)	Flash 1 times and go out 2S	—	E1	4	shutdown
Indoor coil sensor abnormal(TE)	Flash 3 times and go out 2S	—	E3	5	shutdown
Outdoor coil sensor abnormal(TW)	Flash 2 times and go out 2S	Flash 2 times and go out 2S	E2	8	non-stop
Outdoor condensate temp. Sensor abnormal(TL)	Flash 7 times and go out 2S	Flash 7 times and go out 2S	E7	9	non-stop
Discharging temp. sensor abnormal(TP)	Flash 8 times and go out 2S	Flash 8 times and go out 2S	E8	10	non-stop

Note: When correct signal has not been received by wired control or main control board in 2 consecutive min, then the unit turns off and indicates relative failure code, once communication renew and failure code disappears automatically.

7.Failure analysis

Wired controller communication failure

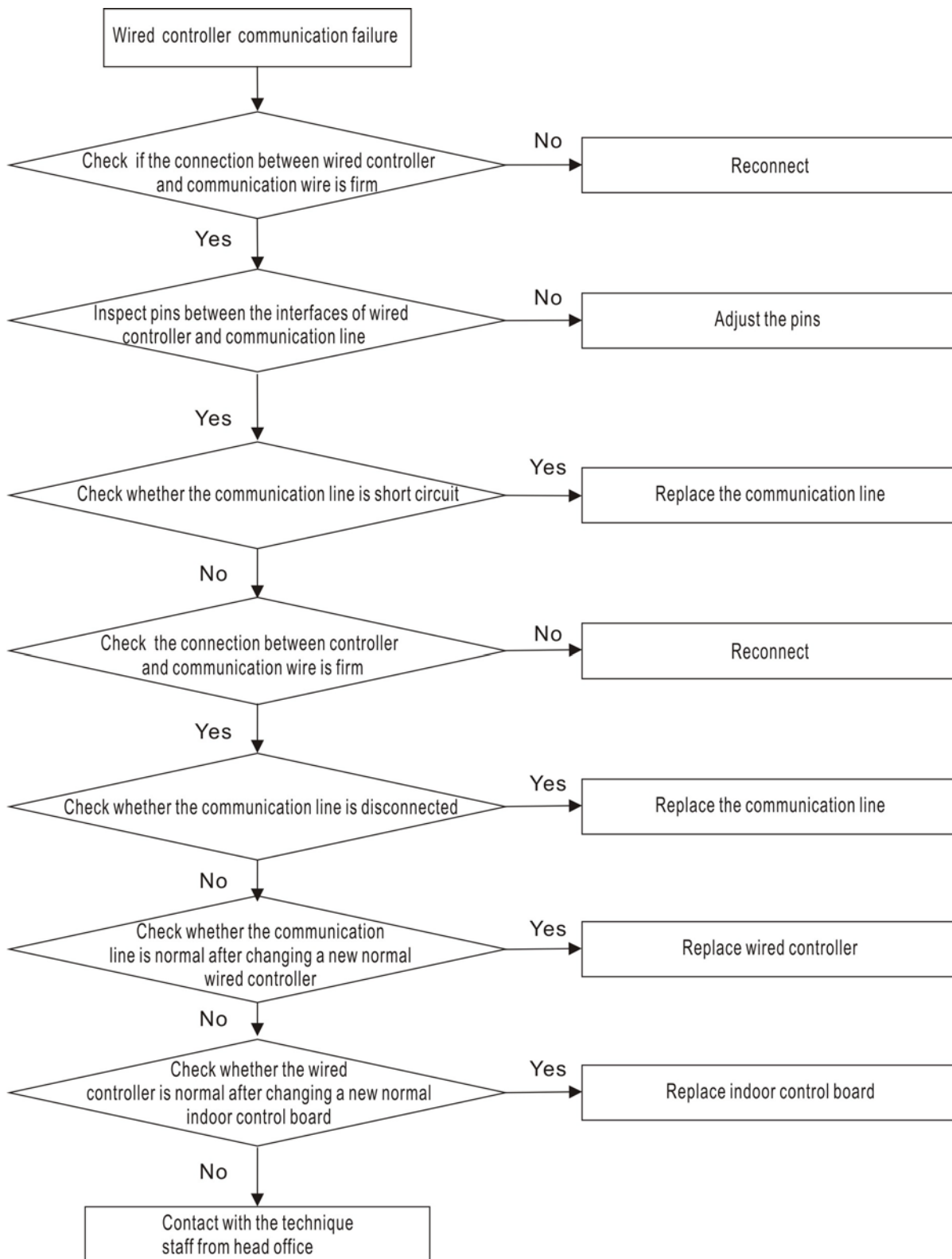

Communication failure between indoor and outdoor unit

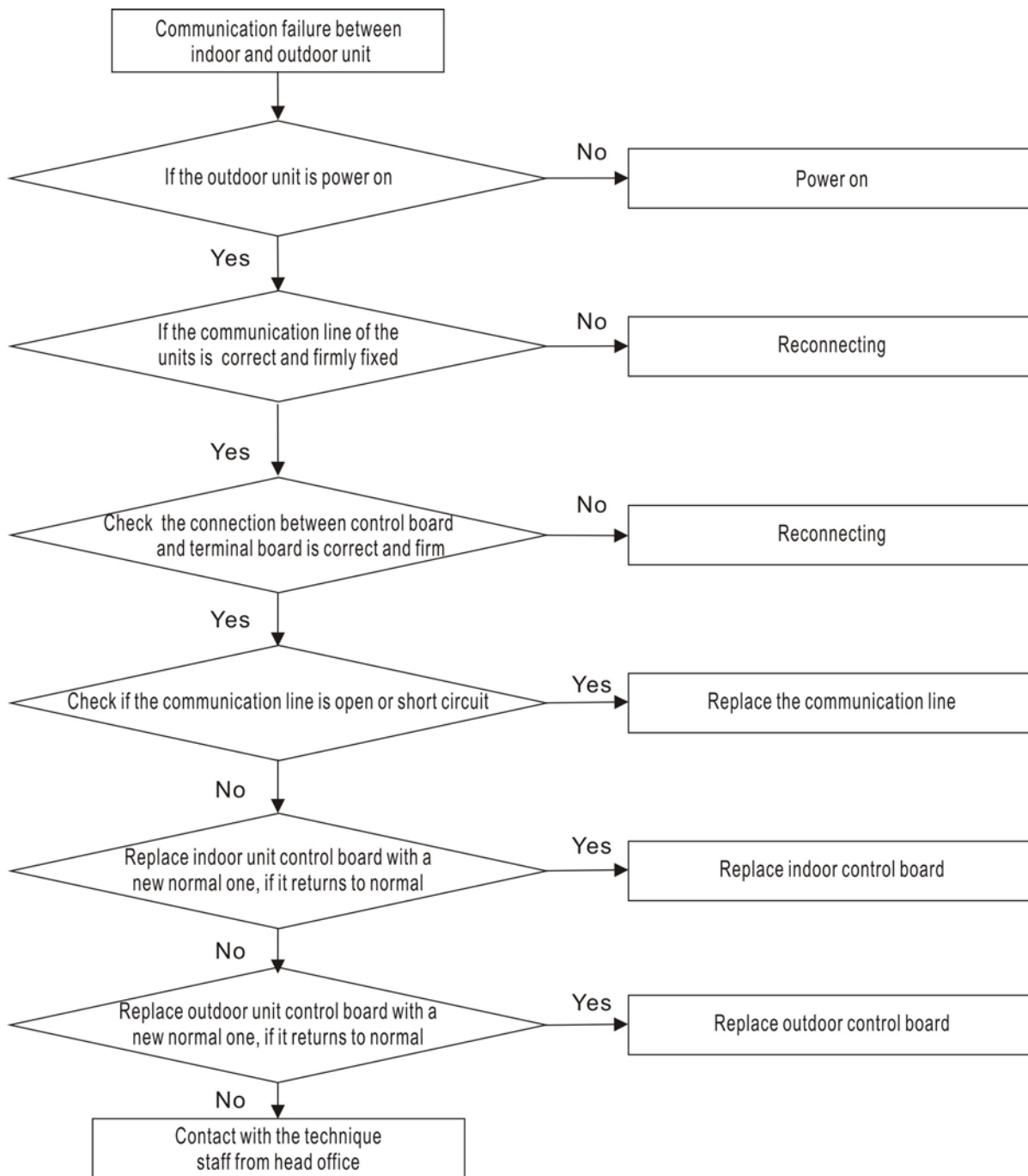

Outdoor protection(phase sequence)

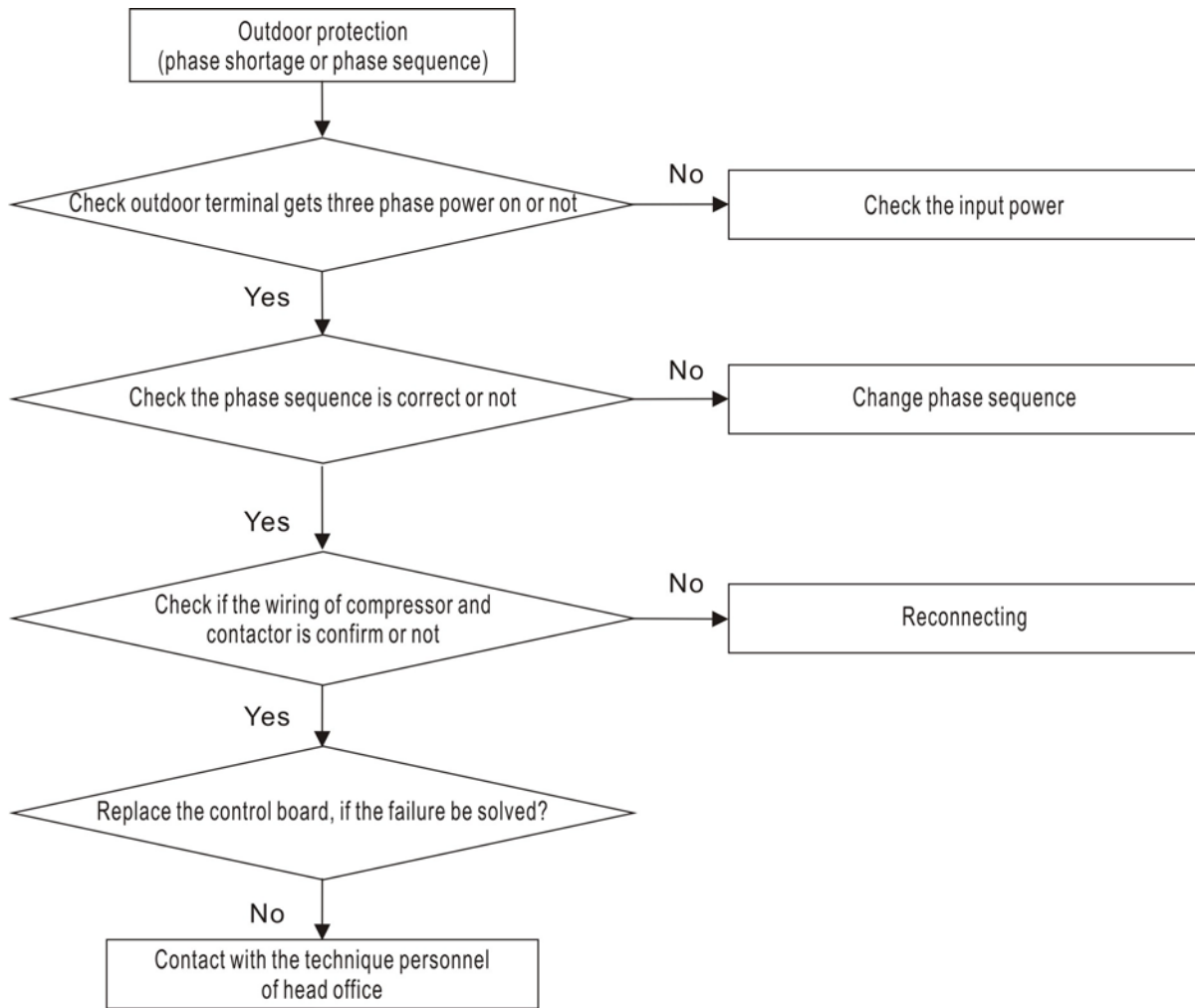

Cooling high pressure protection

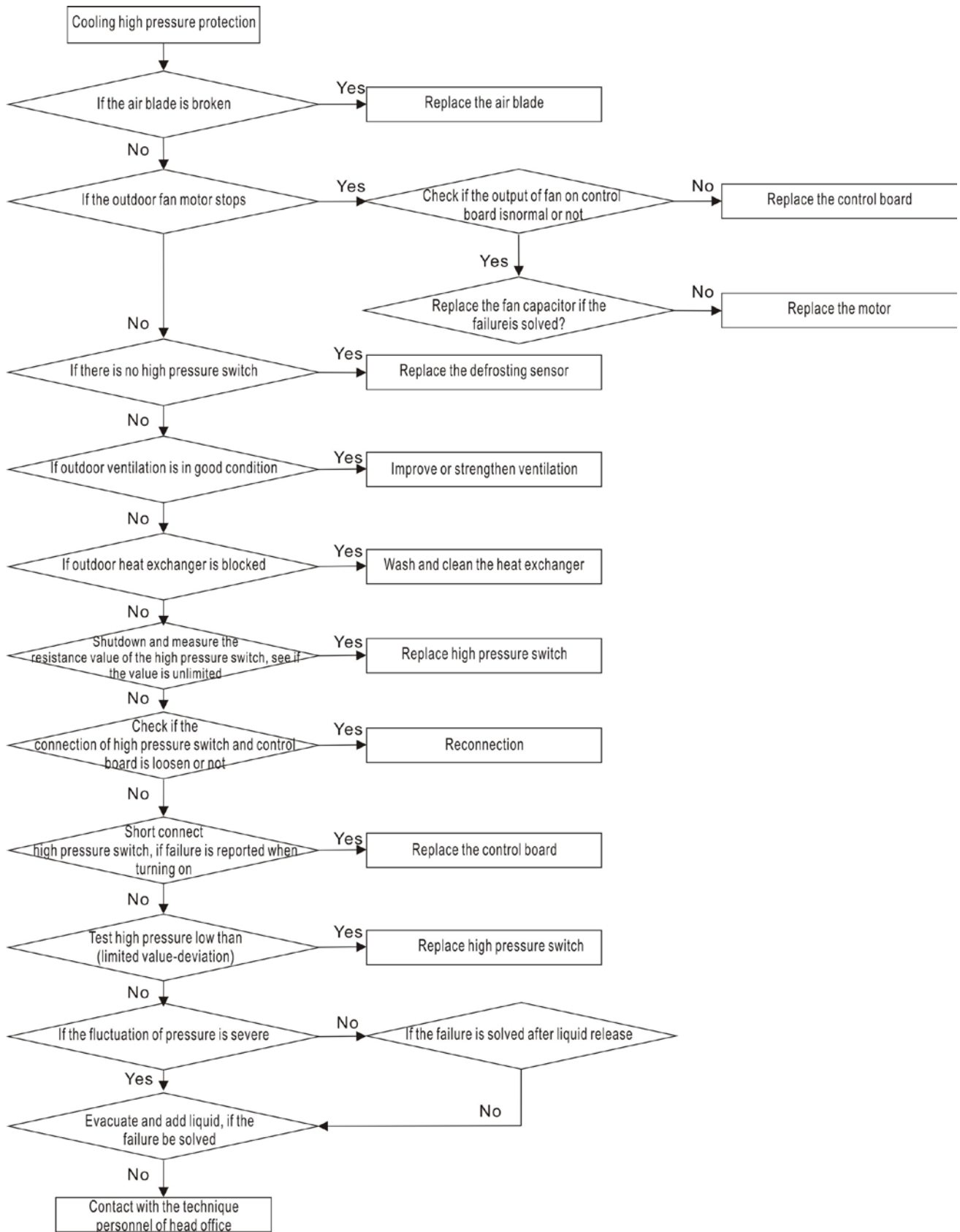

Heating high pressure protection

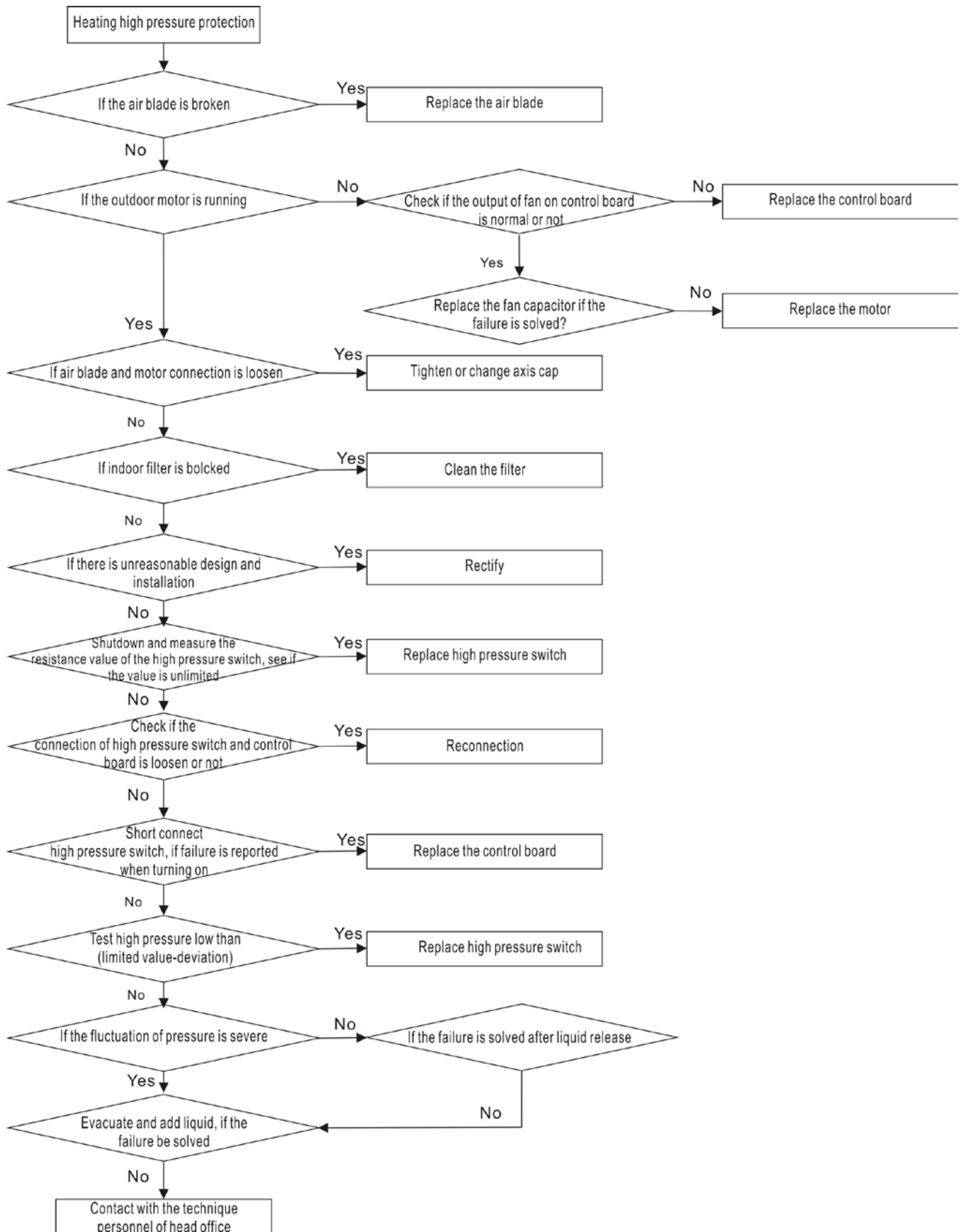

Cooling low pressure protection

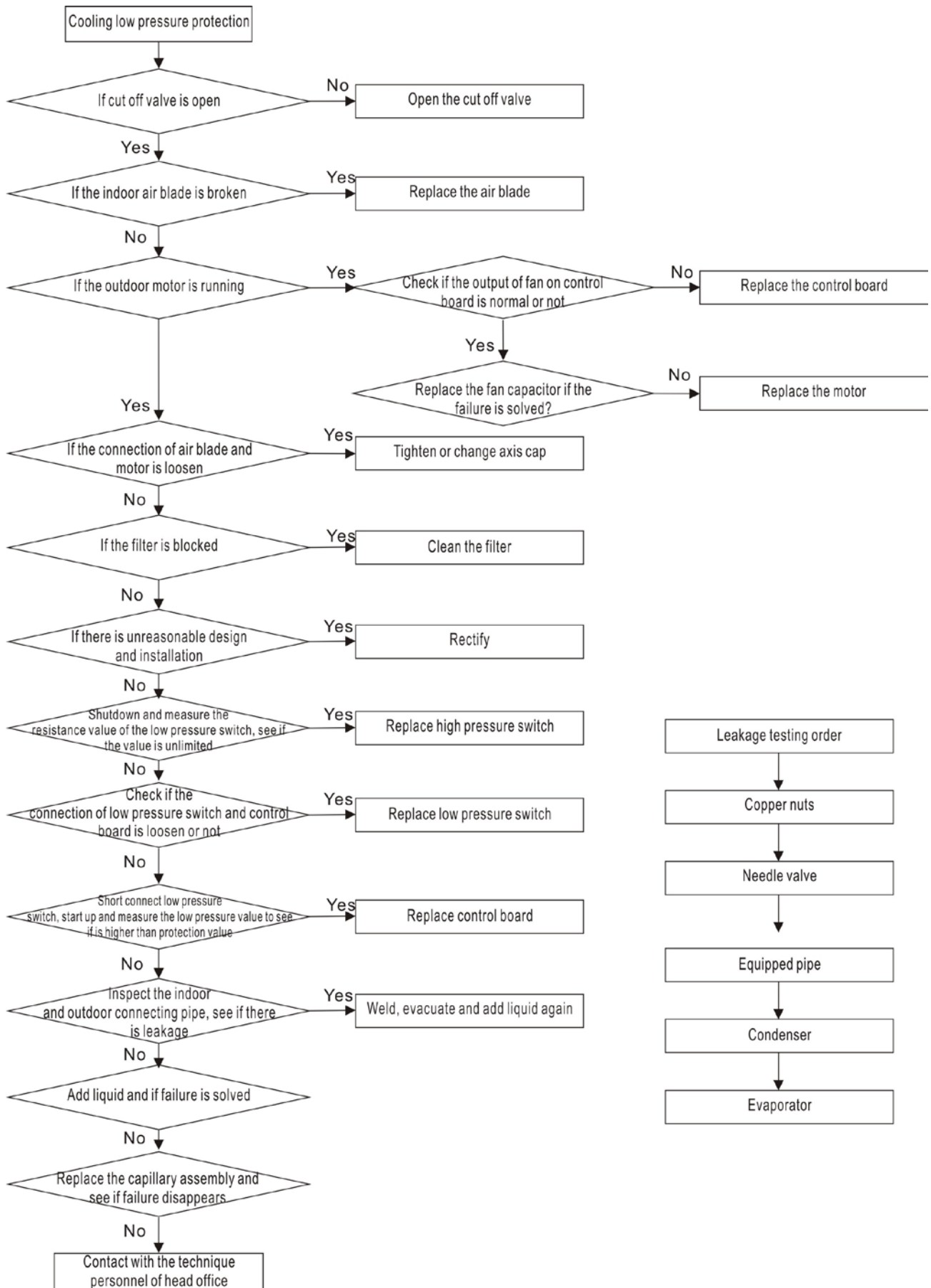

Heating low pressure protection

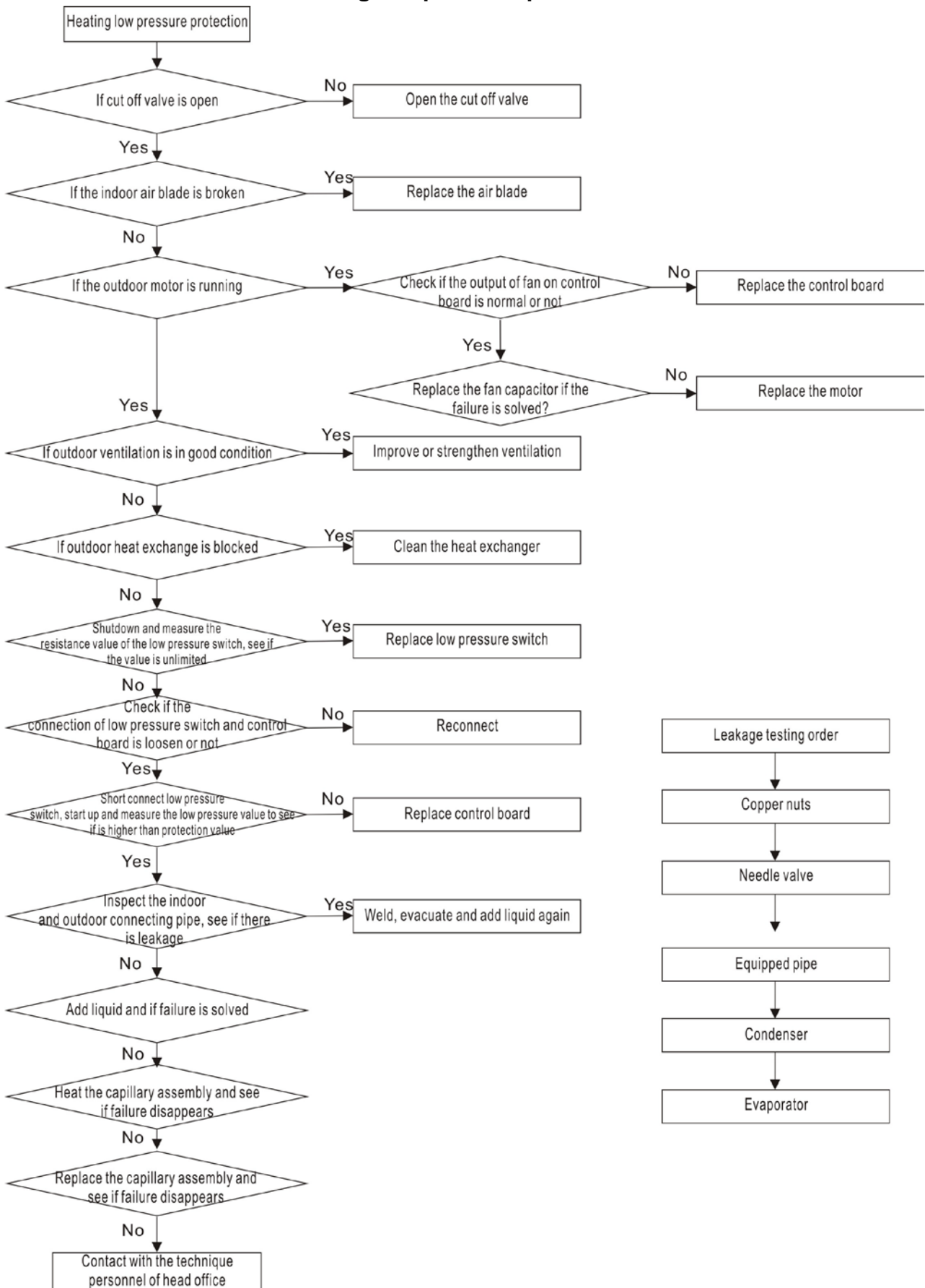

Cooling exhaust temperature protection

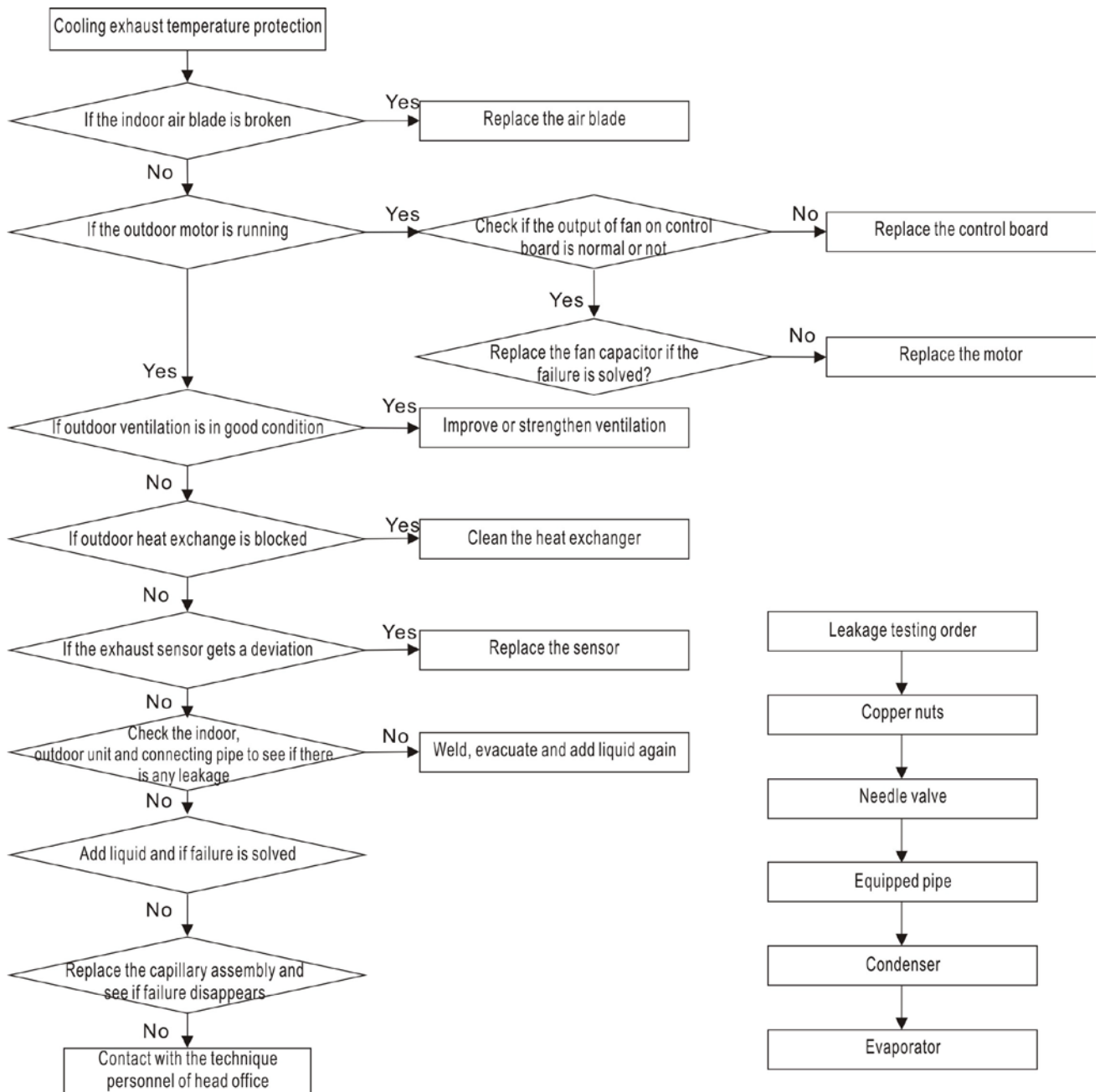

Heating exhaust temperature protection

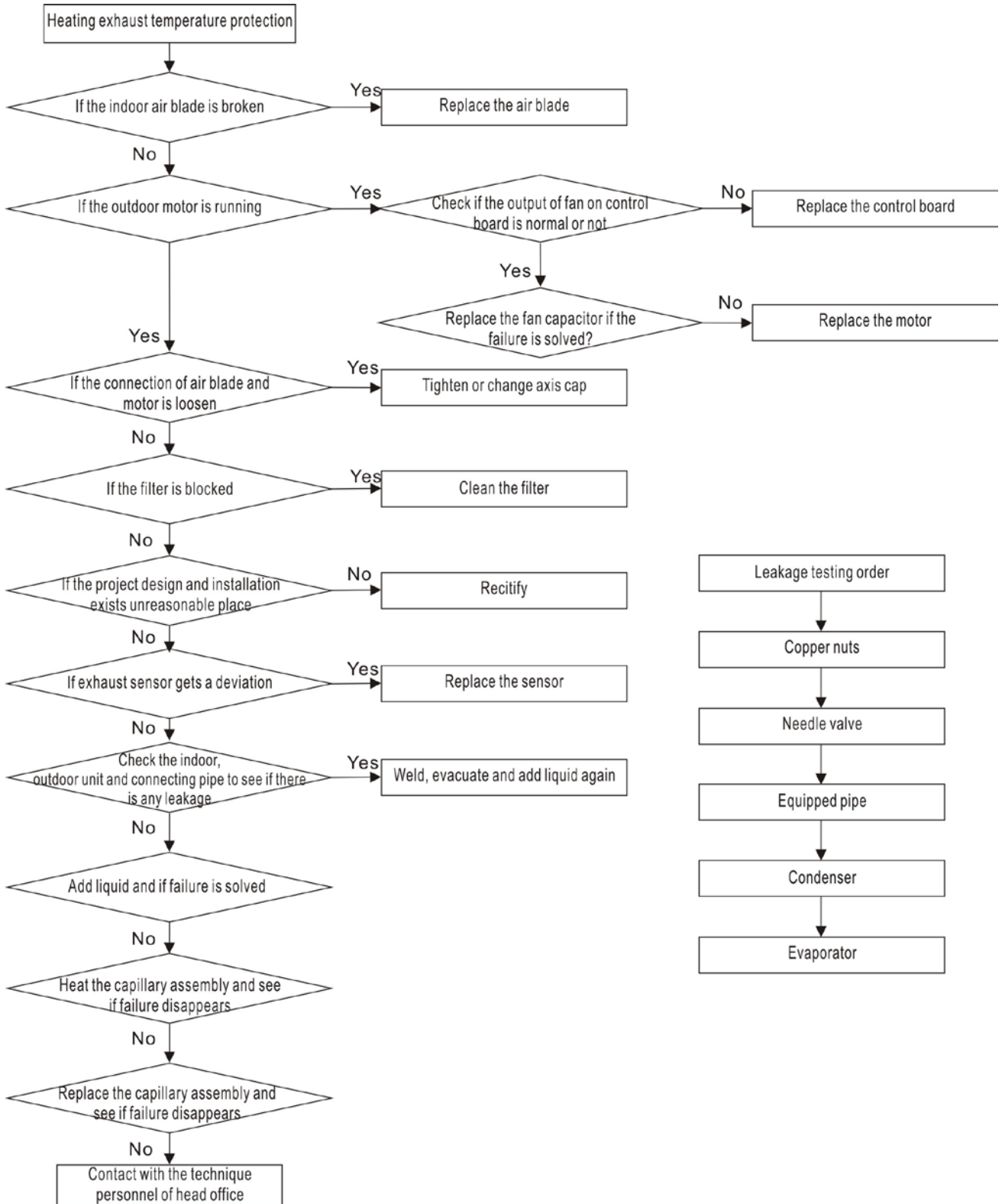

Refrigerant shortage or four way valve failure protection

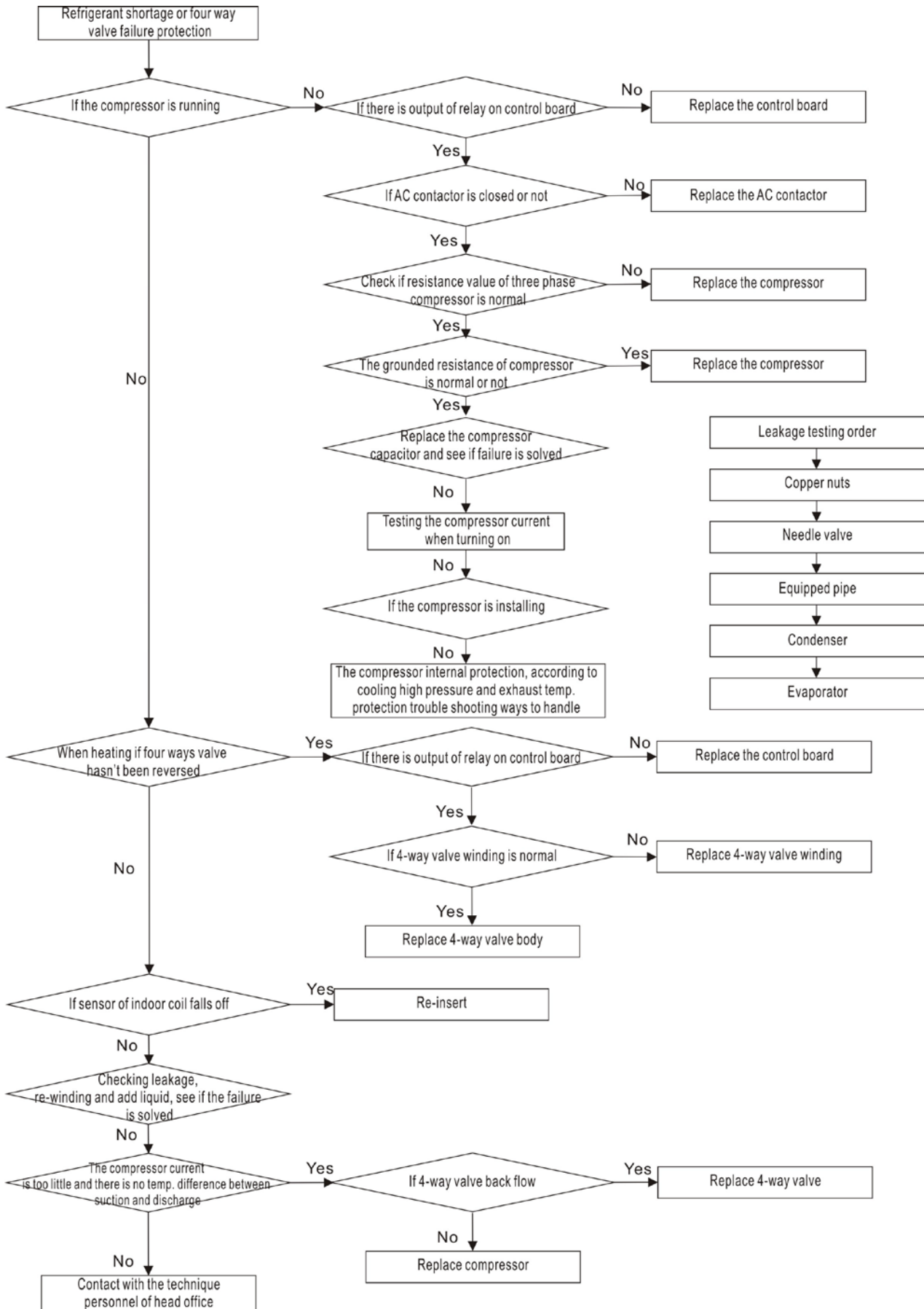

Sensor failure protection

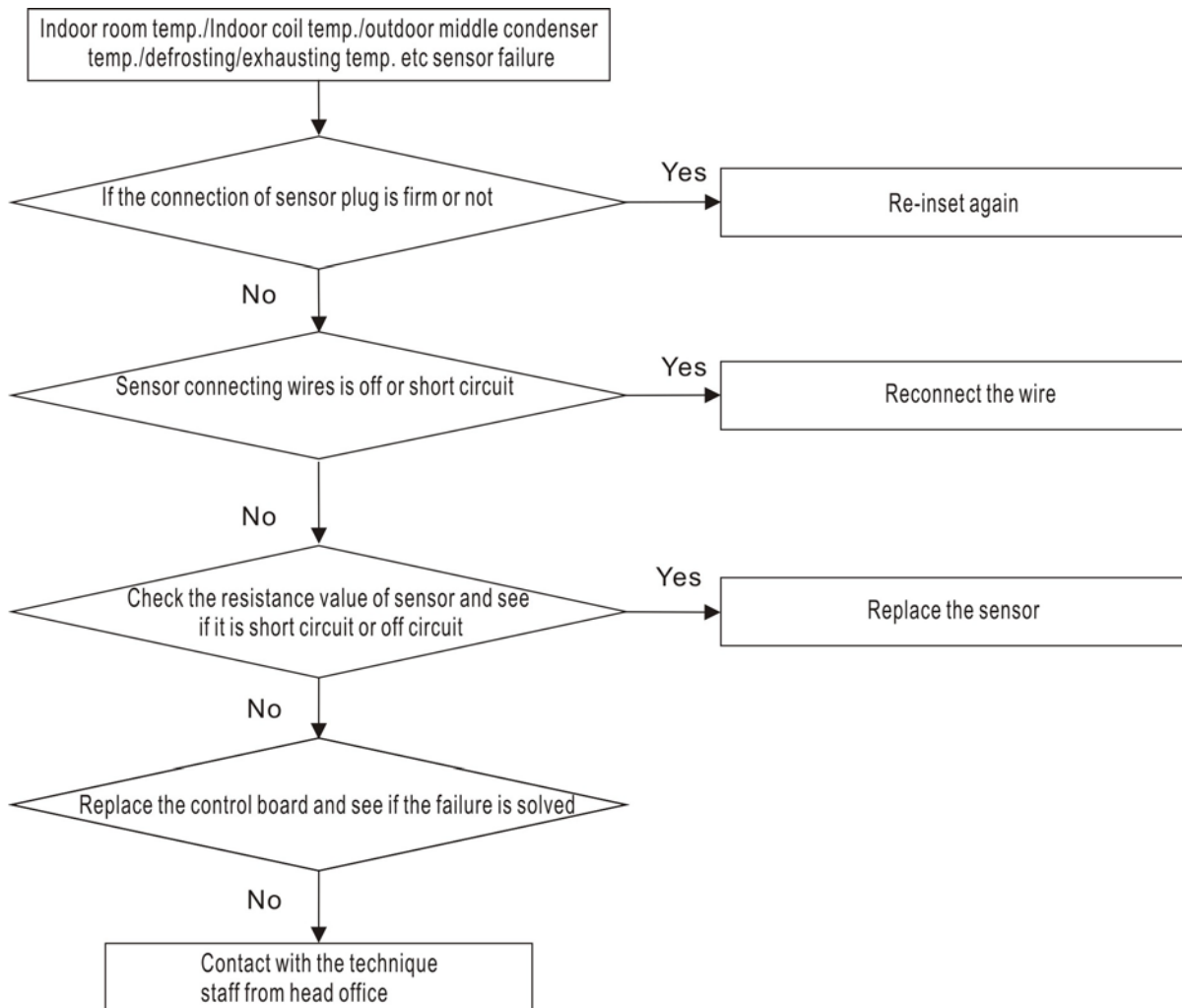

No action after power-on

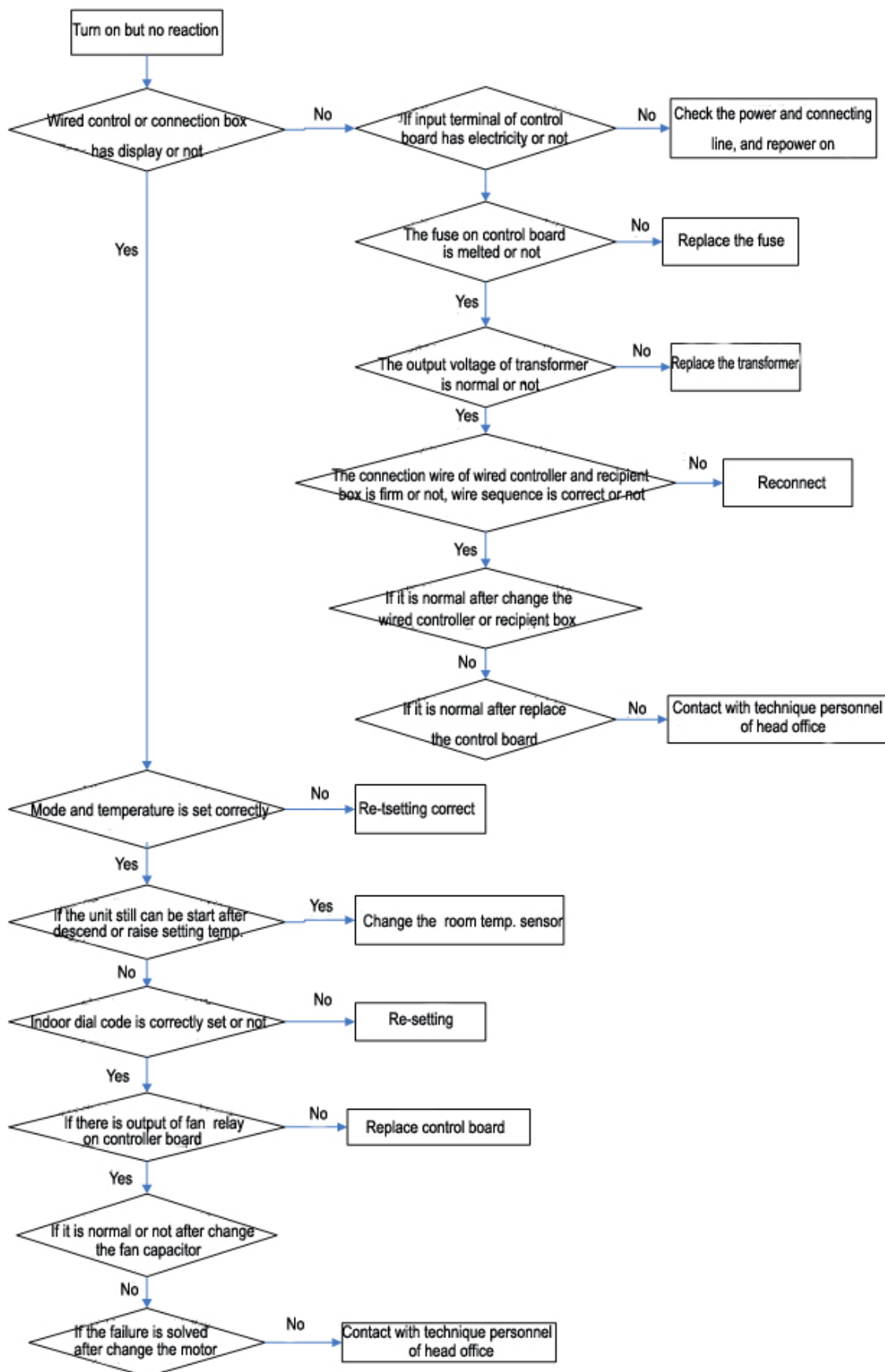

Poor effect

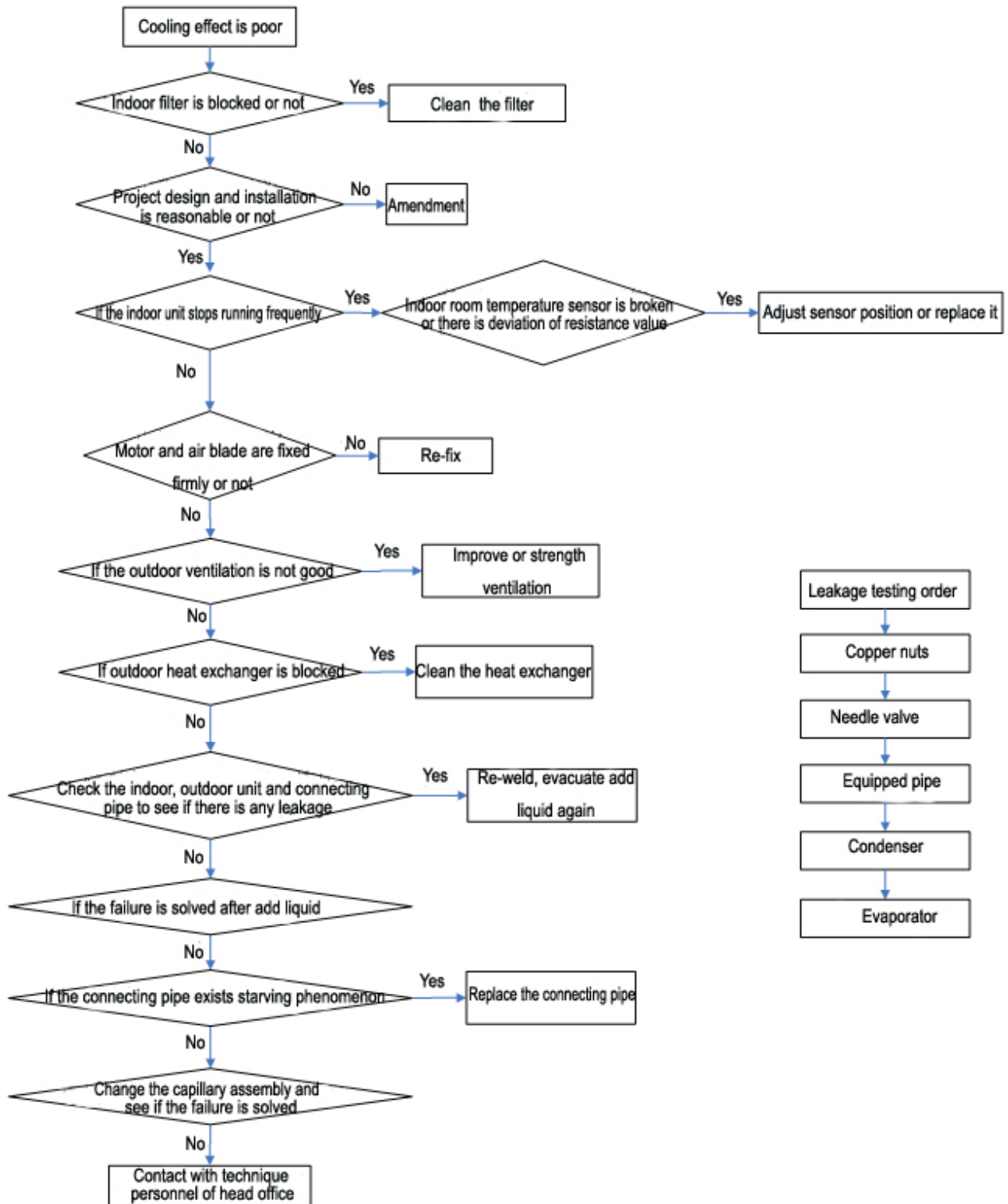

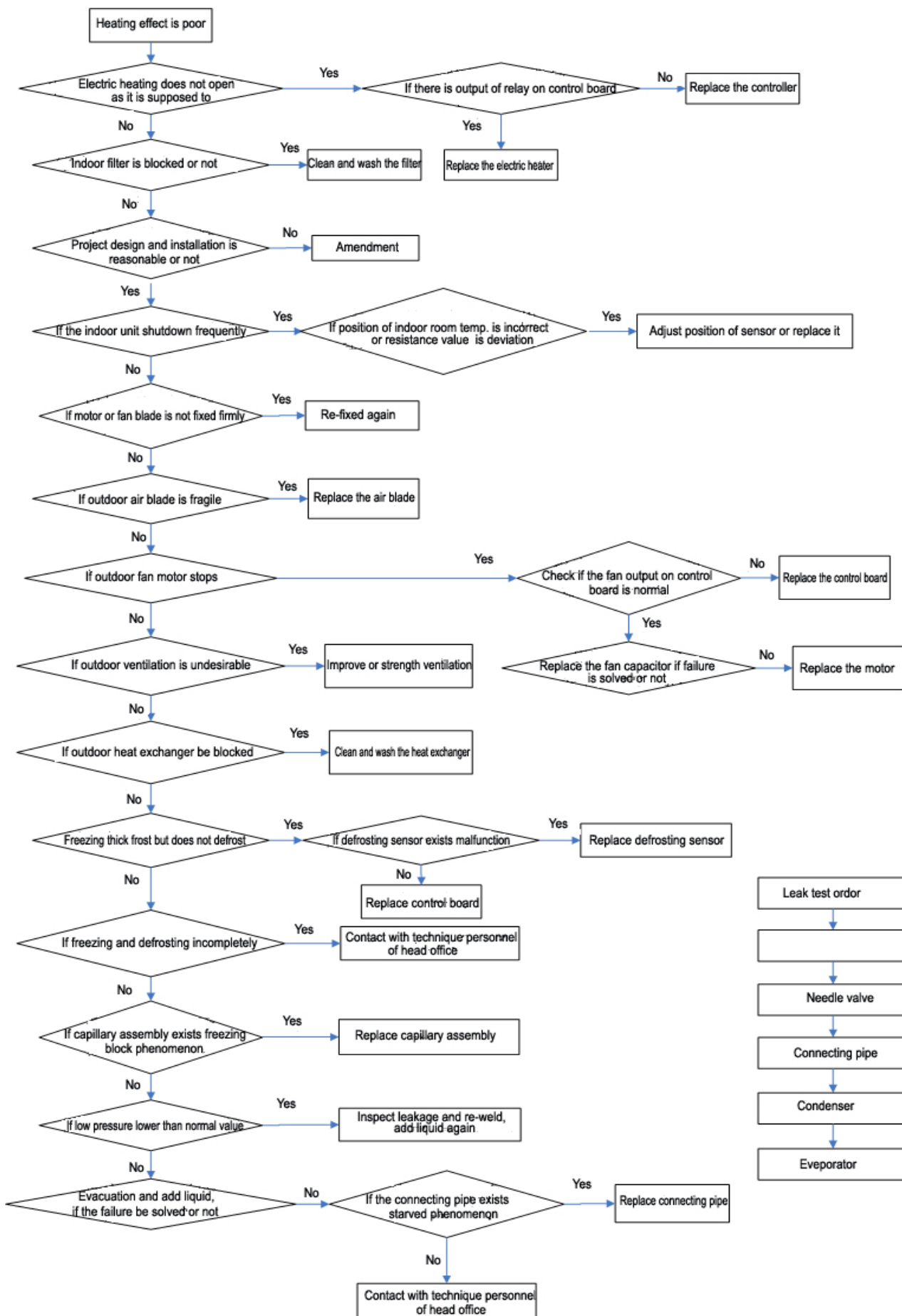

Abnormal sound or vibration

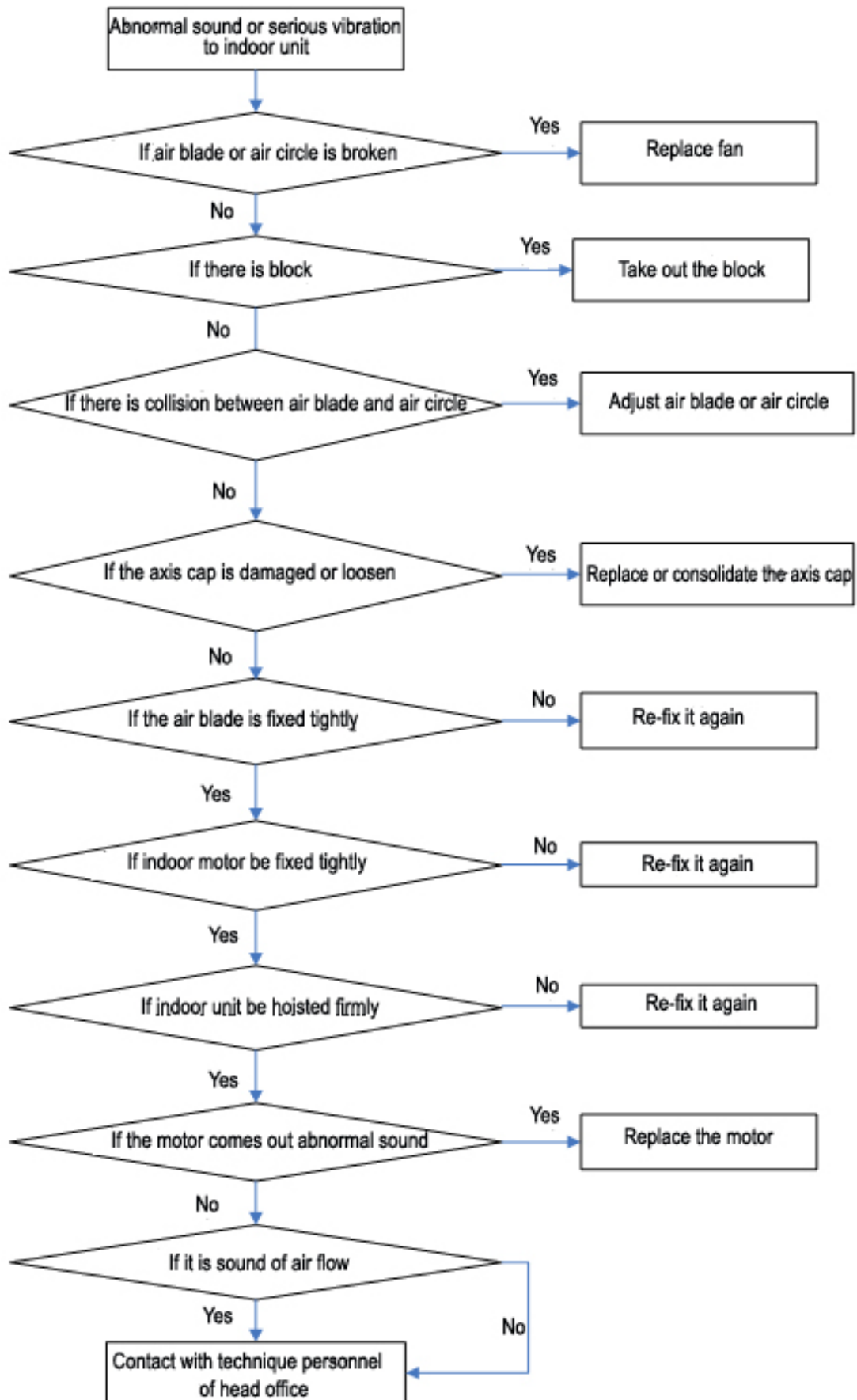

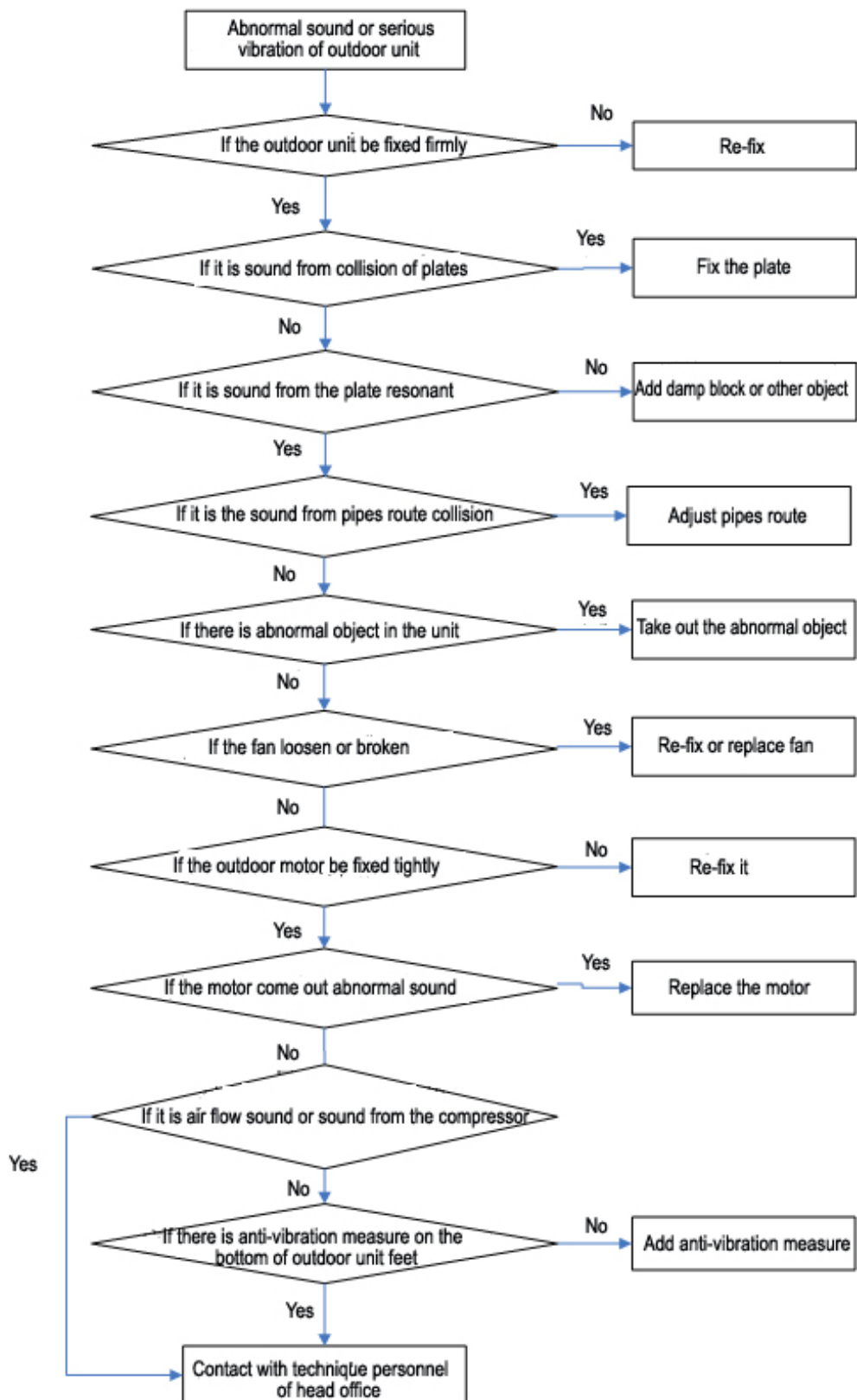

Abnormal odor

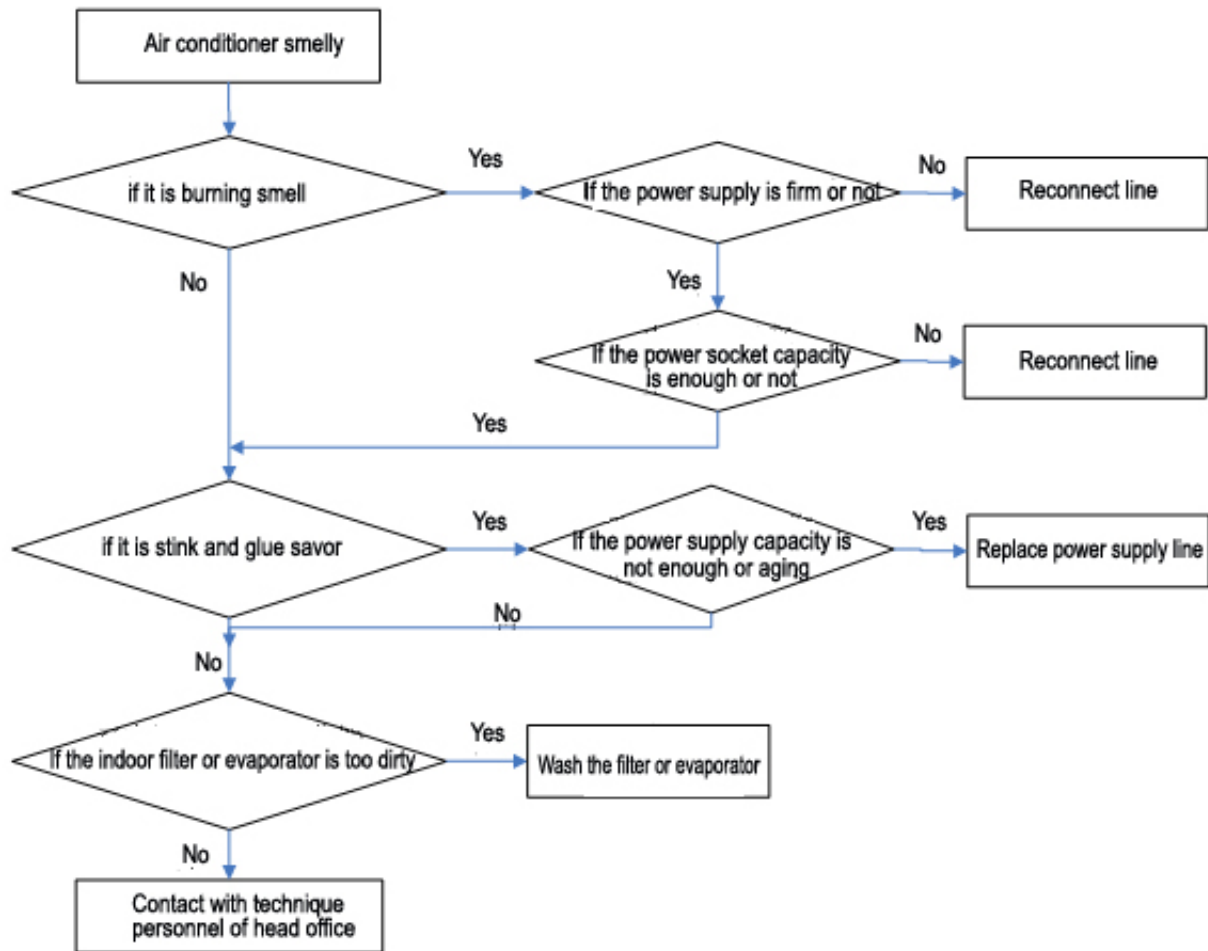

Air switch action when air conditioner starting up

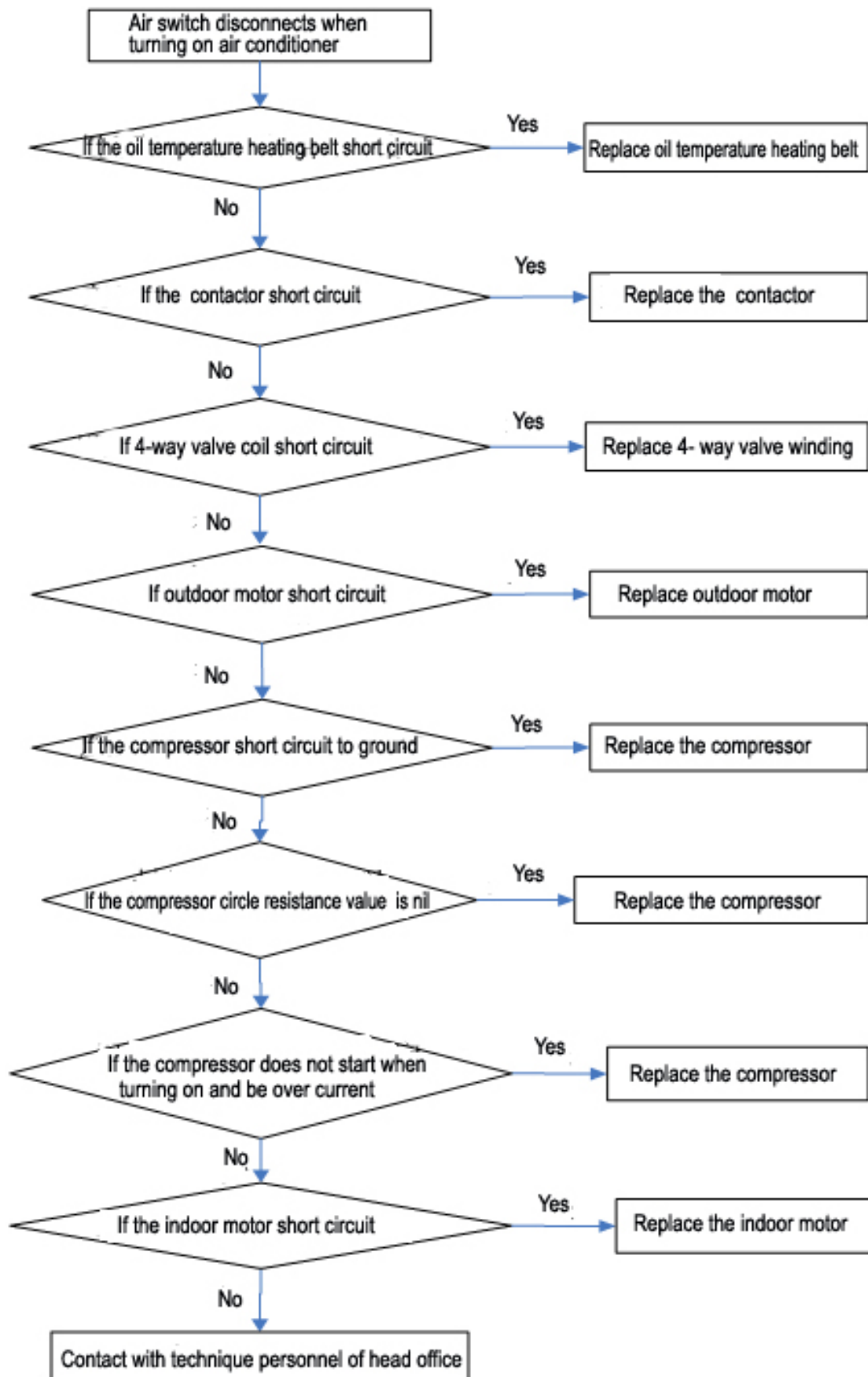

Air conditioner water leakage

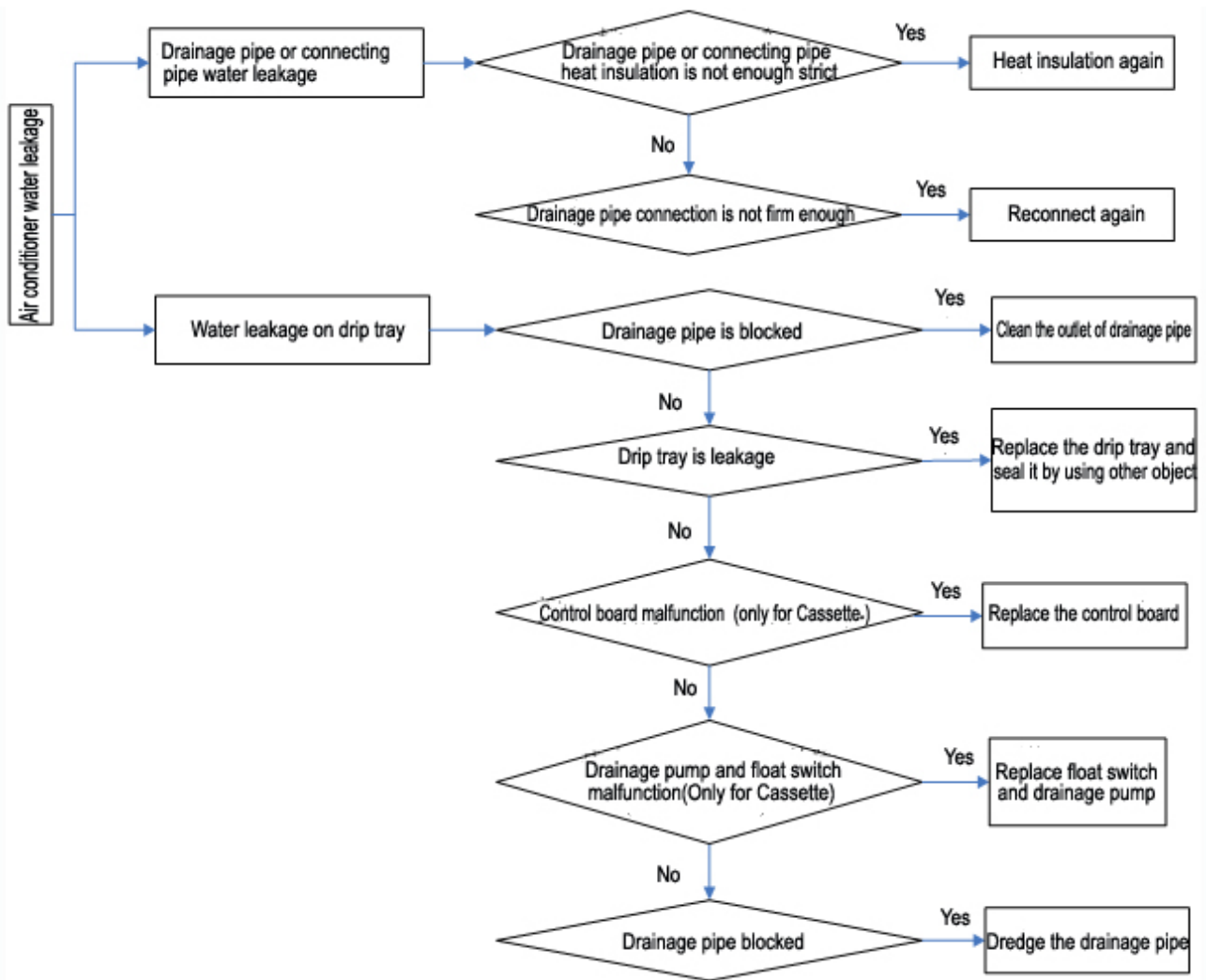





Part 5 Controller

1.General information.....	143
2.Function	145
3.Wired controller	148

1.General information

Remote controller, wired controller, display panel and receiver

Remote controller、wired controller、display panel 、 receiver		
Remote controller		Available for all models above
Wired controller		Available for all models above
Display panel		Available for Cassette indoor unit
Display panel		Available for Ceiling&Floor indoor unit
Receiver		Available for Duct indoor unit
Note	<p>For Cassette and Ceiling & Floor indoor unit, remote controller is standard and wired controller is optional.</p> <p>For Duct indoor unit wired controller is standard,remote controller is optional(remote controller receiver will be necessaryer).</p>	

Remote controller's operation introduction

Basic condition of remote controller

Name	Figure	Basic condition for operation
Remote controller		<p>1. Power source Use 2 pcs No 7 batteries, working voltage: 2.0V-5.0V;</p> <p>2. Signal frequency: infrared frequency 38kHz;</p> <p>3. Remote distance: max working distance is 7m.</p>
		<p>Key operation introduction:</p> <p>1. Temperature setting range 16°C - 32°C ;</p> <p>2. when heating: When indoor coil temp. is lower than request, the fan will change into low speed, .</p> <p>After the temp. reach to the request temp., it will change into setting fan speed.</p>

2.Function

Function

Remote controller: K series

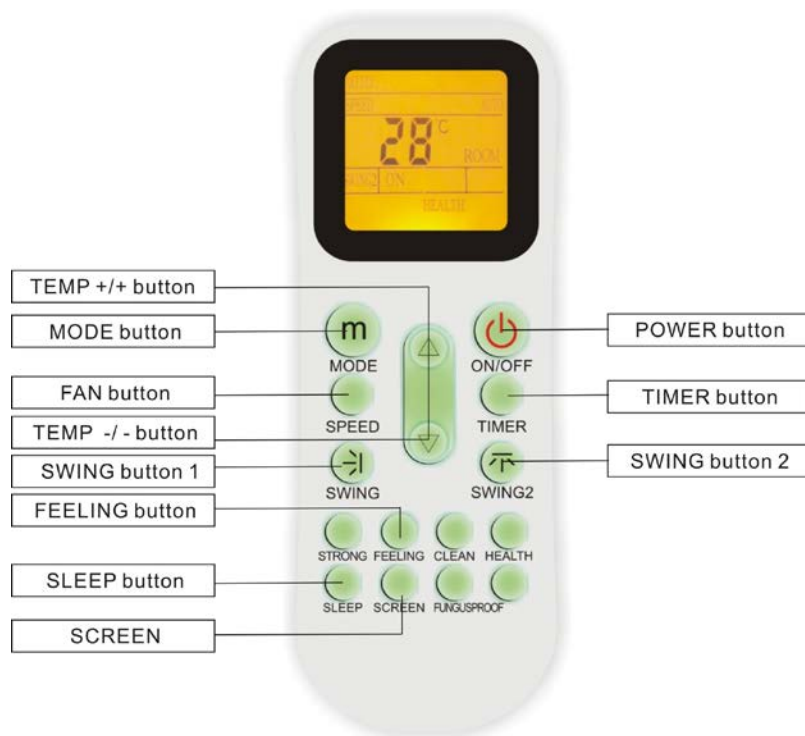

POWER button: Switch the unit ON/OFF.

MODE button: Select mode , push the button one time, then the operation modes will change in turn as Auto-Cooling-Dehumidify-Heating 

TEMP + button and **TEMP - button:** Temperature adjustment range: 16~32

FAN button: Change the fan speed will change in turn as: Low-Medium-High-Auto

SWING button 1: Press this button for the first time when operation, it will start the up and down swing function. Push the button for the second time, cancel the swing function.

SWING button 2: Press this button for the first time when operation, it will start the right and left swing function. Push the button for the second time, cancel the swing function.

Feeling button: Press this button for setting the feeling function. The LCD shows the actual room temperature when the function set and it shows the setting temperature when the function cancelled. The function is invalid when the appliance at the fan mode.

TIMER/CLOCK button:

Clock Setting: Normally display the clock set currently (display 12:00 for the first electrifying or resetting). When press the button for 5 seconds, the time display zone will flicker, then press **【+】** and **【-】** button and to adjust hour that uses 12-hour clock including “A.M.” and “P.M.” time; press the button again to complete the setting.

Timer setting: Press the button to set TIMER ON/OFF , press the button then “ON” will flicker on the display screen. then press **【+】** and **【-】** button and to adjust hour that uses 12-hour clock including “A.M.” and “P.M.” time;press the button again to complete the setting. The “OFF” setting is the same methods.

Remark: When setting functions such as mode, temperature, air port and air velocity, display screen displays all presetting parameters and remains constant; after reaching presetting time, air conditioner will automatically start as per presetting state.

After setting timing ON and OFF function, pressing button of **【Timer/Clock】** can cancel timing setting.

SLEEP button:

1. Press the button to the sleeping indicator light of indoor unit flashes on;
2. After the setting of sleeping mode,the cooling operation enables the set temperature to increase 1°C after 1 hour and another 1°C auto matically after 1hour.
3. After the setting of sleeping mode,the heating operation enables the set temperature to drop 2°C after 1 hour and another 2°C auto matically after 1hour.
4. The air condition runs in sleeping mode for 7hours and stops automatically.

Remark:Press the mode or ON/OFF button,the remote controller clears sleeping mode away.

SCREEN button:Press the button to let the LCD display working or not by pressing the button.

Remote contrroller:H series

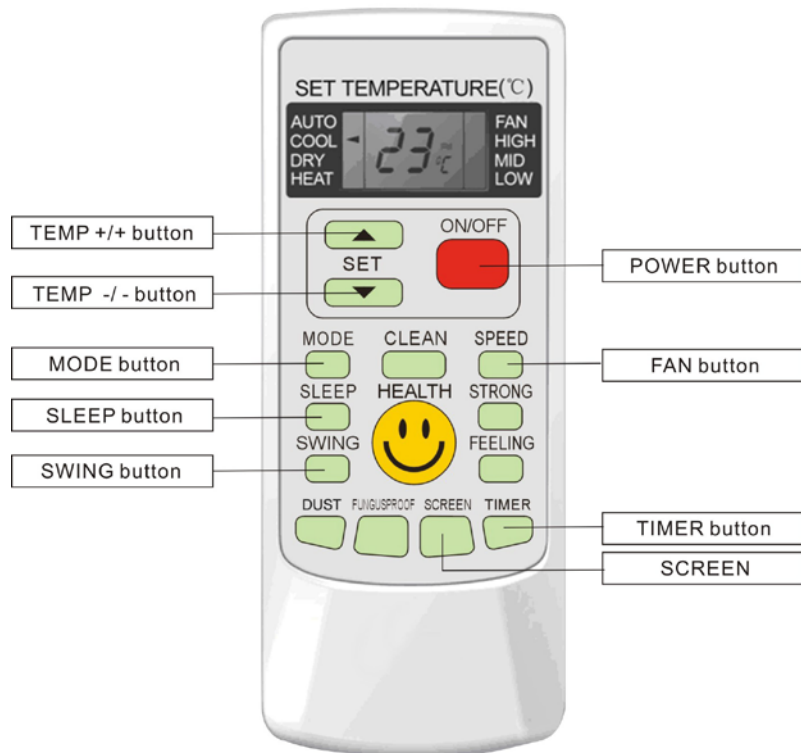

LCD display instruction

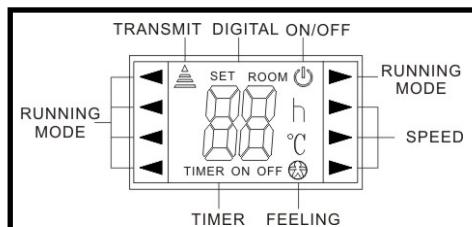

NOTE:
ON/OFF display:
 when the remote controller is on the state, the LCD will be display or not.
Digital display:
 Under the state of normal working, it displays setting temperature. While the

NOTE:Fan speed operation
 When the air volume is greater, the noise will be higher, The wind temperature will rise when cooling mode,and drop when heating mode;
 Please select the appropriate F speed

POWER button:Switch the unit ON/OFF.

MODE button: Select mode, push the button one time, then the operation modes will change in turn as Auto-Cooling-Dehumidify-Heating 

TEMP + button and TEMP - button: Temperature adjustment range: 16~32

FAN button: Change the fan speed will change in turn as: Low-Medium-High-Auto

SWING button: Press this button for the first time when operation, it will start the swing function. Push the button for the second time, cancel the swing function. (The function is available matched with the concerned unit)

TIMER/CLOCK button:

Clock Setting: Normally display the clock set currently (display 12:00 for the first electrifying or resetting). When press the button for 5 seconds, the time display zone will flicker, then press **【+】** and **【-】** button and to adjust hour that uses 12-hour clock including “A.M.” and “P.M.” time; press the button again to complete the setting.

Timer setting: Press the button to set TIMER ON/OFF, press the button then “ON” will flicker on the display screen. then press **【+】** and **【-】** button and to adjust hour that uses 12-hour clock including “A.M.” and “P.M.” time; press the button again to complete the setting. The “OFF” setting is the same methods.

Remark: When setting functions such as mode, temperature, air port and air velocity, display screen displays all presetting parameters and remains constant; after reaching presetting time, air conditioner will automatically start as per presetting state.

After setting timing ON and OFF function, pressing button of **【Timer/Clock】** can cancel timing setting.

SLEEP button:

1. Press the button to the sleeping indicator light of indoor unit flashes on;
2. After the setting of sleeping mode, the cooling operation enables the set temperature to increase 1°C after 1 hour and another 1°C automatically after 1 hour.
3. After the setting of sleeping mode, the heating operation enables the set temperature to drop 2°C after 1 hour and another 2°C automatically after 1 hour.
4. The air condition runs in sleeping mode for 7 hours and stops automatically.

Remark: Press the mode or ON/OFF button, the remote controller clears sleeping mode away.

SCREEN button: Press the button to let the LCD display working or not by pressing the button.

3.Wired controller

3.1 Basic condition of wired controller

Name	Figure	Basic condition for operation
Wired controller		<ol style="list-style-type: none"> 1. Power source:voltage DC 12V; 2. Work temperature range of PCB:(-10~+70)°C; 3. Work humidity range of PCB:RH20%~RH90%;

3.2 Function

Wired controller: XK-01



ON/OFF button:Switch the unit ON/OFF.

Mode button:Select mode , push the button one time, then the operation modes will change in turn as below: Auto-Cooling-Dehumidify-Heating 

Temp + button and Temp - button: Press the button can adjust temperature. Temperature adjustment range: 16~32°C.

Fan button: Change the fan speed will change in turn as :Auto-Low-Medium-High-Auto

Lock button: Press Temp + button and Temp - button meantime.

Remote receiving:Receiving signal of remote controller.

Notes: Virtually all functions of the wired controller are the same as those of the remote controller and you should refer to the remote controller instructions.

Wired controller: XK-02



ON/OFF button: Switch the unit ON/OFF.

Mode button: Select mode , push the button one time, then the operation modes will change in turn as below: Auto-Cooling-Dehumidify-Heating 

Temp +/- button: Press the button can adjust temperature. Temperature adjustment range: 16~32°C.

Fan button: Change the fan speed will change in turn as :Auto-Low-Medium-High-Auto

Swing button: Press this button for the first time when operation, it will start the swing function. Push the button for the second time, cancel the swing function. (The function is available matched with the concerned unit)

Health button: Press this button change to switch mode: Health mode.

SLEEP button:

1. Press the button to the sleeping indicator light of indoor unit flashes on;
2. After the setting of sleeping mode, the cooling operation enables the set temperature to increase 1°C after 1 hour and another 1°C automatically after 1 hour.

3. After the setting of sleeping mode, the heating operation enables the set temperature to drop 2°C after 1 hour and another 2°C automatically after 1 hour.
4. The air condition runs in sleeping mode for 7 hours and stops automatically.

Remark: Press the mode or ON/OFF button, the remote controller clears sleeping mode away.

Timer button: Press the button to set Timer ON/OFF, press the button then “ON” will flicker on the display screen. then press **【Clock +/- button】** and to adjust hour that uses 12-hour clock including “A.M.” and “P.M.” time; press the button again to complete the setting. The “OFF” setting is the same methods.

Remark: When setting functions such as mode, temperature, swing and fan speed, display screen displays all presetting parameters and remains constant; after reaching presetting time, air conditioner will automatically start as per presetting state.

After setting timing ON and OFF function, pressing button of **【Timer】** can cancel timing setting.

Notes:

1. Time sequence of timing ON and OFF determines the order of “Timing ON-Timer OFF” and “Timer OFF- Timing ON”. If the both are the same or either one is the same as time of current clock, it is invalid to press “Timer” button to confirm presetting time; after it reaches the presetting time, it will implement corresponding timing operation.
2. After setting time of timing ON and OFF, pressing “Timer” button can cancel timing.
3. Enter into time setting state of timing function; if there is no input related to time within consecutive 10 seconds, cancel the operation, return to previous state and go on with current time.
4. Default time of timer ON is 08:00 and default time of timer OFF is 18:00.

3.3 Installation of wired controller

- ◇ First, take apart the base panel from the wired controller.;
- ◇ According to the two installation holes on the install board, use two screws to fix the base panel to the wall as shown below;
- ◇ Ensure that the connecting cable of the controller is accessible before connecting the wired controller to the base panel.;
- ◇ Join the wired controller connection cable to the indoor unit using the cable provided.

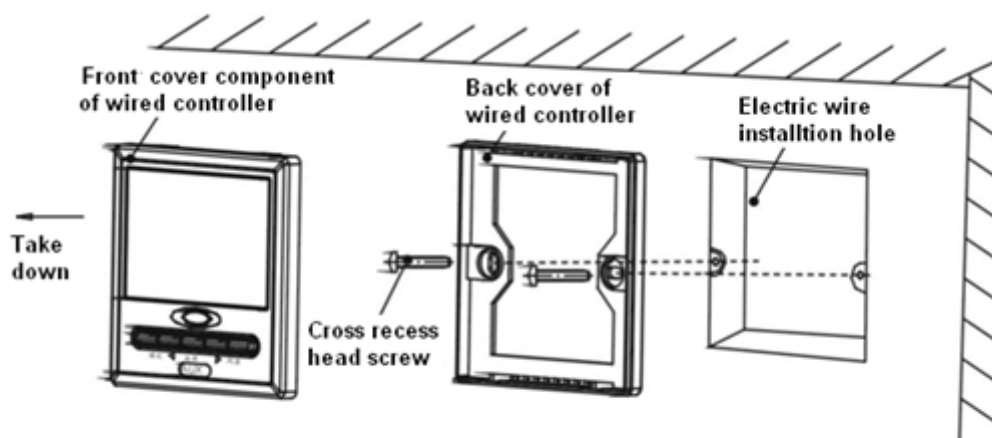

Part 6. Sensor resistance table

Coil and environment temperature sensor 5K3470 resistance reference table

Coil and environment temperature sensor 5K3470					
Tx(°C)	Average (KΩ)	Tx(°C)	Average (KΩ)	Tx(°C)	Average (KΩ)
-20	72.99	21	5.854	61	1.421
-19	35.16	22	5.626	62	1.376
-18	33.43	23	5.408	63	1.334
-17	31.80	24	5.199	64	1.293
-16	30.26	25	5.000	65	1.254
-15	28.80	26	4.811	66	1.215
-14	27.42	27	4.630	67	1.179
-13	26.12	28	4.456	68	1.143
-12	24.88	29	4.291	69	1.109
-11	23.71	30	4.132	70	1.076
-10	22.60	31	3.980	71	1.044
-9	21.55	32	3.835	72	1.013
-8	20.56	33	3.695	73	0.9837
-7	19.61	34	3.562	74	0.9550
-6	18.72	35	3.434	75	0.9273
-5	17.87	72	3.311	76	0.9005
-4	17.06	37	3.193	77	0.8746
-3	16.30	38	3.081	78	0.8496
-2	15.57	39	2.972	79	0.8254
-1	14.88	40	2.869	80	0.8021
0	14.23	41	2.769	81	0.779
1	13.60	42	2.673	82	0.758
2	13.01	43	2.581	83	0.737
3	12.45	44	2.493	84	0.716
4	11.91	45	2.409	85	0.696
5	11.40	46	2.307	86	0.677
6	10.92	47	2.249	87	0.658
7	10.46	48	2.174	88	0.641
8	10.02	49	2.102	89	0.623
9	9.596	50	2.032	90	0.606
10	9.197	72	1.965	91	0.590
11	8.817	52	1.901	92	0.574
12	8.454	53	1.839	93	0.559
13	8.108	54	1.780	94	0.544

14	7.779	55	1.722	95	0.530
15	7.464	56	1.667	96	0.726
16	7.164	57	1.614	97	0.502
17	6.877	58	1.563	98	0.489
18	6.603	59	1.724	99	0.476
19	6.342	60	1.466	100	0.464
20	6.092				

Exhaust temperature sensor 6.339K3954

Exhaust temperature sensor R80: 6.339K Ω \pm 1% B25/80=3954K \pm 1%							
T [°C]	Rmin [K Ω]	T [°C]	Rmin [K Ω]	T [°C]	Rmin [K Ω]	T [°C]	Rmin [K Ω]
-20	440.7	20	60.42	60	12.32	100	3.377
-19	417.0	21	57.79	61	11.89	101	3.279
-18	394.7	22	55.29	62	11.48	102	3.184
-17	373.7	23	52.91	63	11.08	103	3.093
-16	353.9	24	50.65	64	10.70	104	3.003
-15	335.2	25	48.49	65	10.34	105	2.918
-14	317.7	26	46.44	66	9.992	106	2.836
-13	301.2	27	44.49	67	9.652	107	2.755
-12	285.6	28	42.64	68	9.328	108	2.678
-11	271.0	29	40.88	69	9.017	109	2.603
-10	257.1	30	39.19	70	8.717	110	2.530
-9	244.0	31	37.59	71	8.428	111	2.460
-8	231.7	32	36.06	72	8.152	112	2.392
-7	220.0	33	34.59	73	7.885	113	2.326
-6	209.0	34	33.21	74	7.628	114	2.262
-5	198.6	35	31.88	75	7.381	115	2.201
-4	188.7	36	30.60	76	7.143	116	2.141
-3	179.4	37	29.39	77	6.914	117	2.083
-2	170.7	38	28.23	78	6.693	118	2.026
-1	162.4	39	27.13	79	6.480	119	1.972
0	154.5	40	26.07	80	6.276	120	1.920
1	147.1	41	25.06	81	6.075	121	1.868
2	140.0	42	24.09	82	5.881	122	1.819
3	133.3	43	23.17	83	5.694	123	1.772
4	127.1	44	22.29	84	5.514	124	1.725
5	121.1	45	21.44	85	5.340	125	1.680
6	115.4	46	20.64	86	5.175	126	1.636
7	109.9	47	19.86	87	5.014	127	1.594
8	104.9	48	19.13	88	4.859	128	1.552
9	100.0	49	18.42	89	4.711	129	1.513
10	95.43	50	17.74	90	4.567	130	1.475

11	91.07	51	17.09	91	4.429	131	1.437
12	86.93	52	16.46	92	4.294	132	1.401
13	83.00	53	15.87	93	4.166	133	1.365
14	79.26	54	15.30	94	4.040	134	1.331
15	75.71	55	14.74	95	3.920	135	1.297
16	72.33	56	14.22	96	3.803	136	1.266
17	69.13	57	13.71	97	3.691	137	1.234
18	66.08	58	13.23	98	3.583	138	1.204
19	63.18	59	12.77	99	3.478	139	1.174